

TECHNICAL MANUAL

**OPERATOR'S, ORGANIZATIONAL, DIRECT
SUPPORT, AND GENERAL SUPPORT MAINTENANCE
MANUAL INCLUDING REPAIR PARTS LIST
FOR**

**SAW, BAND, METAL CUTTING
MODEL 3613-20**

**NSN 3405-00-351-9704
(DOALL COMPANY)**

HEADQUARTERS, DEPARTMENT OF THE ARMY

JULY 1981

WARNINGS

1. **To Avoid Potential Hazards, Observe These Precautions When Operating Or Servicing This Machine-Operator Must:**
 - Wear safety glasses.**
 - Wear gloves-when handling saw band.**
 - Not wear gloves when operating machine.**
 - Set saw guides as close to work as possible.**
 - Close band wheel covers before tensioning band or starting machine.**
 - Close doors, replace all covers and safety guards before operating machine.**
 - Use a fixture to feed work piece and keep hands away from moving saw band.**
 - Avoid contact with coolant. Especially guard your eyes.**
 - Step to one side and away from welding unit before welding a saw band.**
 - Install friction band and spark shield before friction sawing.**
 - Use a dust collector when sawing generates dust.**
 - Disconnect electrical supply before removing panels or drive covers.**

2. **Disconnect Electric Power To The Welder Before Making Adjustments.**

3. **All Adjustments Must Be Made With The Power Off, Except Where Specifically Instructed Otherwise.**

INSTRUCTIONS FOR REQUISITIONING PARTS

NOT IDENTIFIED BY NSN

When requisitioning parts not identified by National Stock Number, it is mandatory that the following information be furnished to the supply officer.

- 1 - Manufacturer's Federal Supply Code Number - 18056
- 2 - Manufacturer's Part Number exactly as listed herein.
- 3 - Nomenclature exactly as listed herein, including dimensions, if necessary.
- 4 - Manufacturer's Model Number - 3613-20
- 5 - Manufacturer's Serial Number (End Item)
- 6 - Any other information such as Type, Frame Number, and Electrical Characteristics, if applicable.
- 7 - If DD Form 1348 is used, fill in all blocks except 4, 5, 6, and Remarks field in accordance with AR 723-50.

Complete Form as Follows:

(a) In blocks 4, 5, 6, list manufacturer's Federal Supply Code Number - 18056 followed by a colon and manufacturer's Part Number for the repair part.

(b) Complete Remarks field as follows:
Noun: (nomenclature of repair part)
For: NSN: 3405-00-351-9704
Manufacturer: Continental Machines, Inc.
for

Model: 3613-20 DoALL Company
Serial: (of end item)

Any other pertinent information such as Frame
Number, Type, Dimensions, etc.

DAMAGE CLAIM PROCEDURE

VISIBLE DAMAGE AT TIME OF DELIVERY

1. Note damage on carrier's delivery receipt. Accept the shipment. It can be returned later if repairs aren't possible in the field.
2. Request a "damage inspection" from the delivering carrier:
 - a. The carrier will send his own people or contract an independent agency to make the inspection.
 - b. The inspector will request a signature on the report and leave a copy.
 - c. The carrier "damage inspection" report isn't final. If additional damage is found when repairs are started, contact the carrier for another inspection; or, at least give them the details of the damage.
3. Don't move the equipment from the receiving area and keep all shipping materials until the carrier "damage inspection" report is complete.
4. If possible, take photographs of the damage and keep them with your file. Photos could possibly prove a claim at a later time.
5. Keep a record of all expenses and be sure they are documented.
6. Repair damage in the field whenever possible. Carriers encourage this to keep expenses down.
7. You have 9 months to file a claim.

CONCEALED DAMAGE

1. You have 14 days after delivery to report damage not noted at time of delivery.
 - a. Report damage as soon as possible. This makes it easier to prove that it didn't happen in consignee's plant.
 - b. Inspect machines carefully before moving from the receiving area. Again if machine isn't moved it's easier to prove your case.
2. Request a "damage inspection" from the delivering carrier:
 - a. The carrier will send his own people or contract an independent agency to make the inspection.
 - b. The inspector will request a signature on the report and leave a copy.
 - c. The carrier "damage inspection" report isn't final. If additional damage is found when repairs are started, contact the carrier for another inspection; or, at least give them the details of the damage.
3. Don't move the equipment from the receiving area and keep all shipping materials until the carrier "damage inspection" report is complete.
4. If possible, take photographs of the damage and keep them with your file. Photos could possibly prove a claim at a later time.
5. Keep a record of all expenses and be sure they are documented.
6. Repair damage in the field whenever possible. Carriers encourage this to keep expenses down.
7. You have 9 months to file a claim.

Technical Manual }
No. 9-3405-215-14&P }

HEADQUARTERS
DEPARTMENT OF THE ARMY
Washington, DC, 10 July 1981

**OPERATOR'S, ORGANIZATIONAL, DIRECT SUPPORT
AND GENERAL SUPPORT MAINTENANCE MANUAL
INCLUDING REPAIR PARTS LIST
FOR
SAW, BAND, METAL CUTTING
MODEL 3613-20
(NSN 3405-00-351-9704)**

REPORTING OF ERRORS

You can help improve this manual. If you find any mistakes or if you know of a way to improve the procedures, please let us know. Mail your letter, DA Form 2028 (Recommended Changes to Publications and Blank Forms), or DA Form 2028-2, located in the back of this manual direct to: Commander, US Army Armament Materiel Readiness Command, ATTN: DRSAR-MAS, Rock Island, IL 61299. A reply will be furnished direct to you.

NOTE

Manufactured by: Continental Machines, Inc.
Savage, Minnesota 55378
for
DoAll Company
254 N. Laurel Avenue
Des Plaines, IL 60016

Procured under Contract No. DAAA09-79-C-4136

This technical manual is an authentication of the manufacturers' commercial literature and does not conform with the format and content specified in AR 310-3, Military Publications. This technical manual does, however, contain available information that is essential to the operation and maintenance of the equipment.

TABLE OF CONTENTS

INSTALLATION		TROUBLE SHOOTING	15
Location	1	ACCESSORIES	
OSHA Notice	1	Variable Weight Power Feed	16
Lifting	1	No. 1 All-Purpose Cut-Off	16
Uncrating	1	Disk Cutting	17
Electrical Installation	1	Screw Feed	17
Alignment	1-2	Spiral Saw Band Guides	18
Preparation For Use	2	Roller Saw Band Guides	18
Machine Dimensions	3	Insert-type Saw Guides	18
MACHINE CONTROLS & FEATURES	4-5	90° Saw Band Guide Brackets	19
OPERATION		Rip Fence	19
Safety Precautions	6	No. 2 Cut-Off & Ripping (Side Mount)	19
Using The Job Selector	6	Universal Vise	19
Insert-Type Saw Guide Adjustment	7	Universal Calibrated Work Fixture	20
Band Installation	7	Mist Coolant Applicator	20
Band Removal	7	Drip Type Coolant Applicator	21
Band Tensioning	7	Air Pump & Chip Blower	21
Band Tracking	8	Ball Transfer Strips	21
Post Adjustment	8	Heavy Work Clamps	21
Speed Control	8	Heavy Work Slides	22
Work Table	8	Work Light & Magnifier	22
Table Tilt Adjustment	9	Chip Pan	22
Chip Removal	9	Spark Guard for Friction Sawing	22
Welding Saw Bands	9	Secondary (Auxiliary) Table.....	23
Manual Contour Sawing	9-10	Dust Spout	23
LUBRICATION		Welder	23
Lubrication Diagram	12	Blade Shear	23
Lubrication Chart	13	Etching Pencil	23
MAINTENANCE		Work Table Option	23
Head Assembly	14	Sliding Table (Air Feed)	23
Chip Removal	14	Supply Cabinet	23
Replacing Wheel Tires	14	Band Filing	24-25
Transmission	14	File Guides	25
Drive Belts	14	Band Polishing	25-26
Saw Guides	15		

INSTALLATION

LOCATION

The machine should be located so that adequate space is provided for your cutting needs. You will also want to provide sufficient clearance around the machine for maintenance and lubrication procedures, plus operation of any accessories accompanying the machine.

Floor area required for the machine itself is 40 inches (1025 mm) by 73 inches (1850 mm). Maximum machine height is 74 inches (1885 mm).

NOTICE!!!

OSHA Regulation No. 1910.212 (B). Machines designed for a fixed location shall be securely anchored to prevent walking or moving.

LIFTING

You will find a tapped hole in the machine head's upper surface. Screw a forged 3/4-10 UNC eyebolt into this hole to lift machine into position, or for later moving it to another location. Lifting by overhead hoist is recommended. Machine weight is 1565 pounds (705 kg).

UNCRATING

Carefully remove all protective coverings, strappings, hold-down brackets, and skid. Check inside rear drive housing for other removable brackets, extra machine parts, or supplies placed there for shipment. Unfasten power feed weight hold-down bracket (if accessory is supplied).

Use solvent to remove rust-preventive coating applied to all exposed bare metal surfaces prior to shipment. Inspect machine for broken or damaged parts.

ELECTRICAL INSTALLATION

Bring line circuit leads into electrical enclosure on machine column. Refer to wiring diagram furnished.

Check air discharge nozzle for proper rotation of chip blower pump.

Overload protection is provided. If machine is started and stopped repeatedly and in rapid succession, the overload relay may be tripped. Let relay cool a few minutes before starting machine.

ALIGNMENT

Machine must be properly aligned before being bolted into position. Follow these procedures:

- (1) Release band tension. Remove band. Remove post saw guard and table center plate, plus upper and lower saw guides.

CAUTION
ALWAYS WEAR GLOVES WHEN
HANDLING SAW BANDS.

- (2) Re-install band over each wheel. Tension to maximum reading on tension indicator.
- (3) Shim between base mounting pads and floor until machine is level and weight rests evenly on all pads. Check by tapping with bar or hammer.
- (4) Post front should be parallel with lower keeper block's machined saw guide mounting recess. Check by placing spacer block - ground to exactly 0.250-inch (6.35 mm) thickness -- in keeper block. Place an accurate straight edge against spacer block and post. Use a feeler gage to check post clearance and parallelism to straight edge. Clearance should not exceed 0.004-inch (0.1 mm) in 4 inches (100 mm). See Fig. 1.

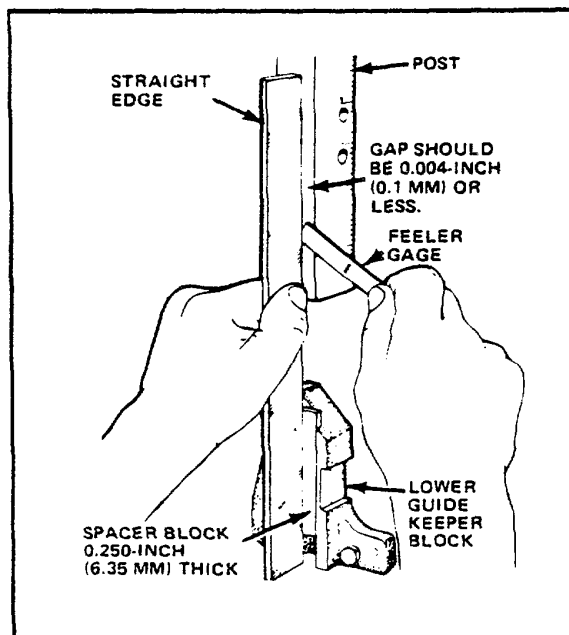

FIG. 1. ALIGN POST TO LOWER SAW GUIDE KEEPER BLOCK.

- (5) Clearance greater than 0.004-inch (0.1 mm) should be corrected by shimming under base pad. Remove shims to increase clearance; add shims to decrease clearance. See Fig. 2.

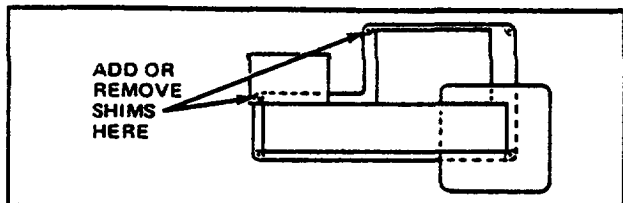

FIG. 2. SHIMMING LOCATION - TOP VIEW.

- (6) Square table to post side by loosening table tilt lock nut, and making necessary adjustment. Adjust tilt angle pointer to "zero", if necessary. Tighten lock nut. See Fig. 3.

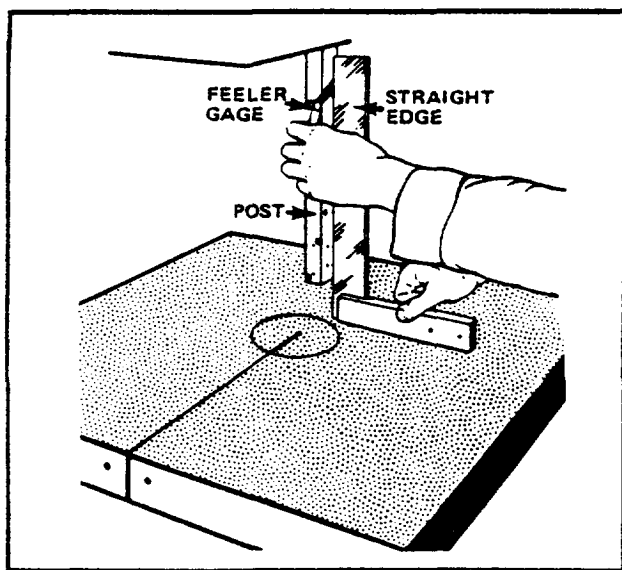

FIG. 3. SQUARING TABLE TO POST.

- (7) Re-install post saw guard, saw guides, inserts, and table center plate.

CAUTION

Bolt machine to floor for table loads exceeding 100 pounds (45 kg).

PREPARATION FOR USE

- (1) Check transmission oil level. Fill with product recommended in Lubrication Chart. Fill until oil level is at elbow plug level. Capacity is 1 quart (0.95 liters).
- (2) Check to see that all other points listed on Lubrication Chart have been properly serviced.

MACHINE DIMENSIONS

FIGURES IN PARENTHESES ARE MILLIMETERS, OTHERS ARE INCHES.

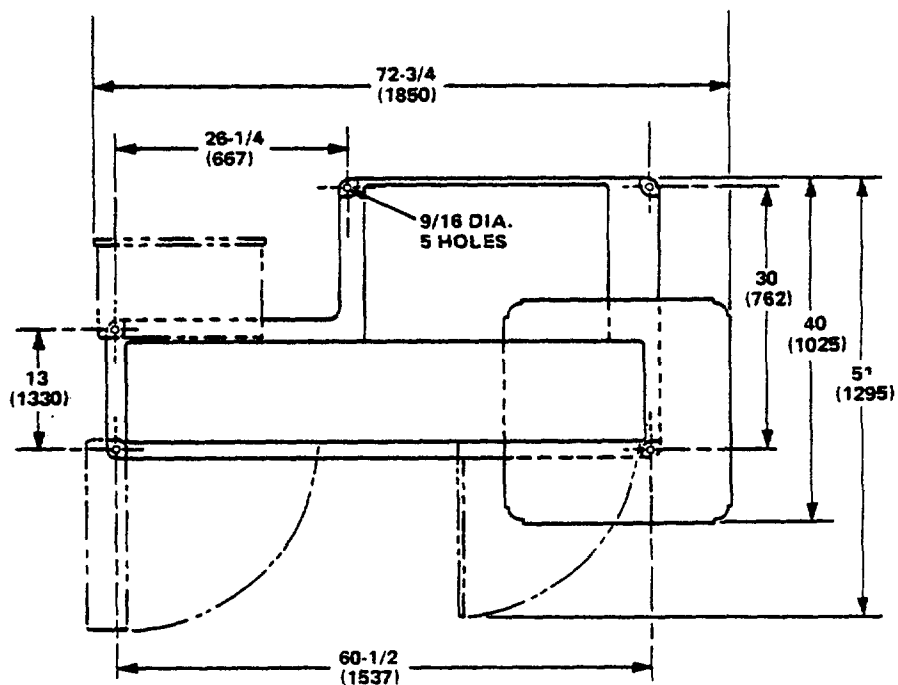
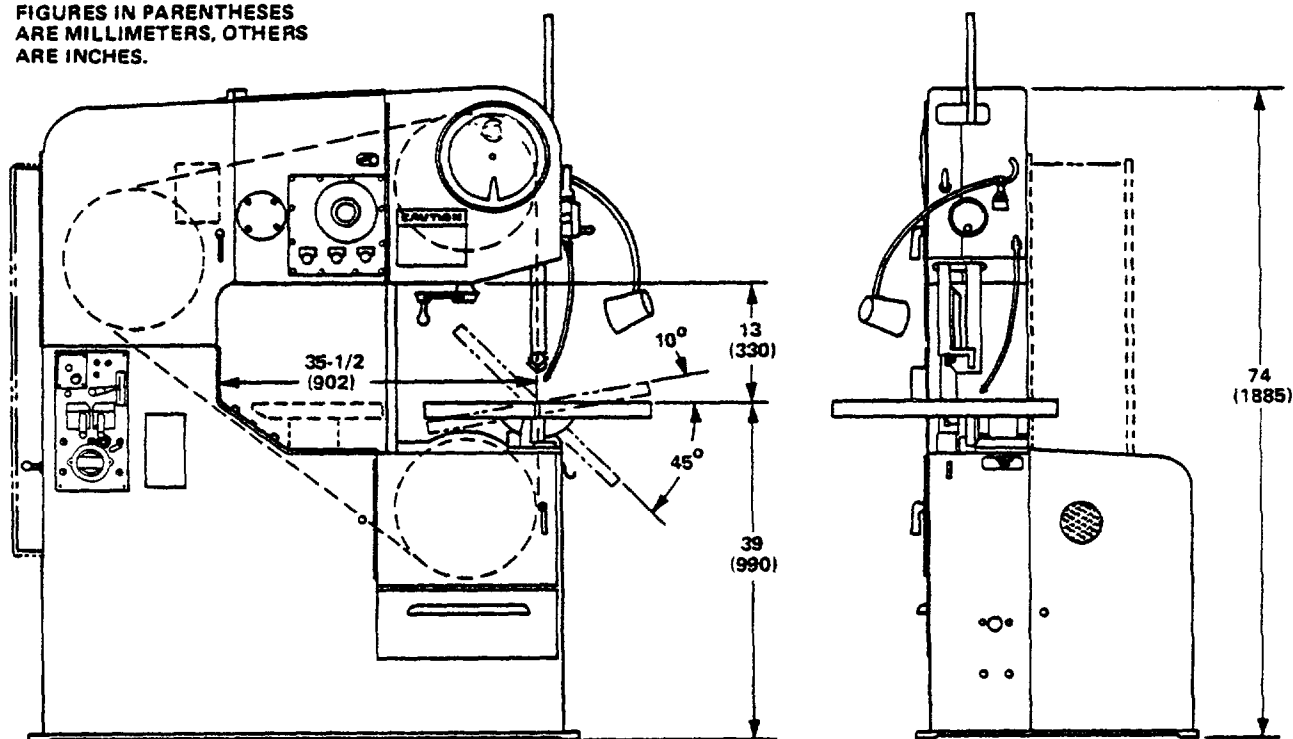

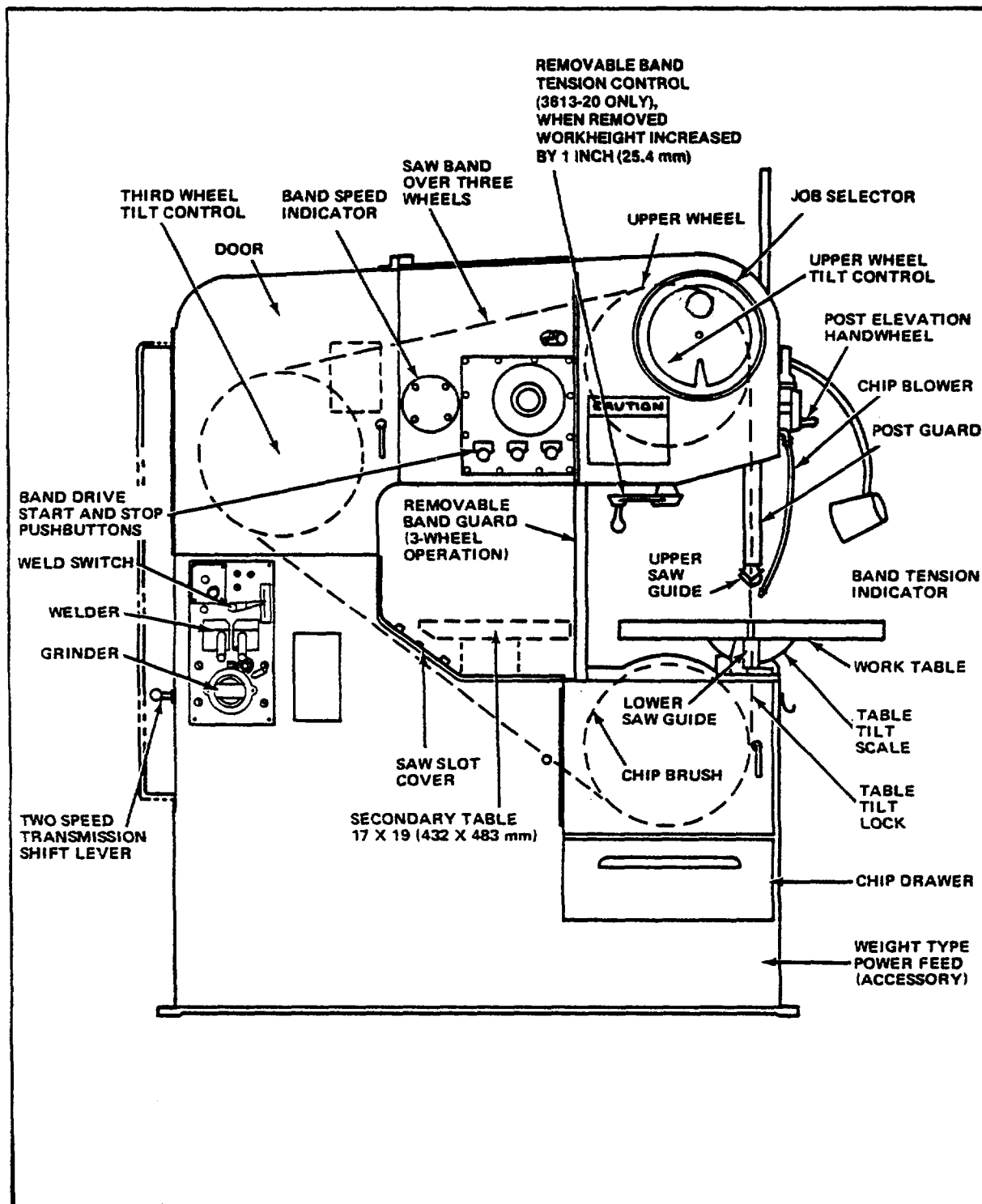

FIG. 4. CONTROLS AND FEATURES, FRONT VIEW

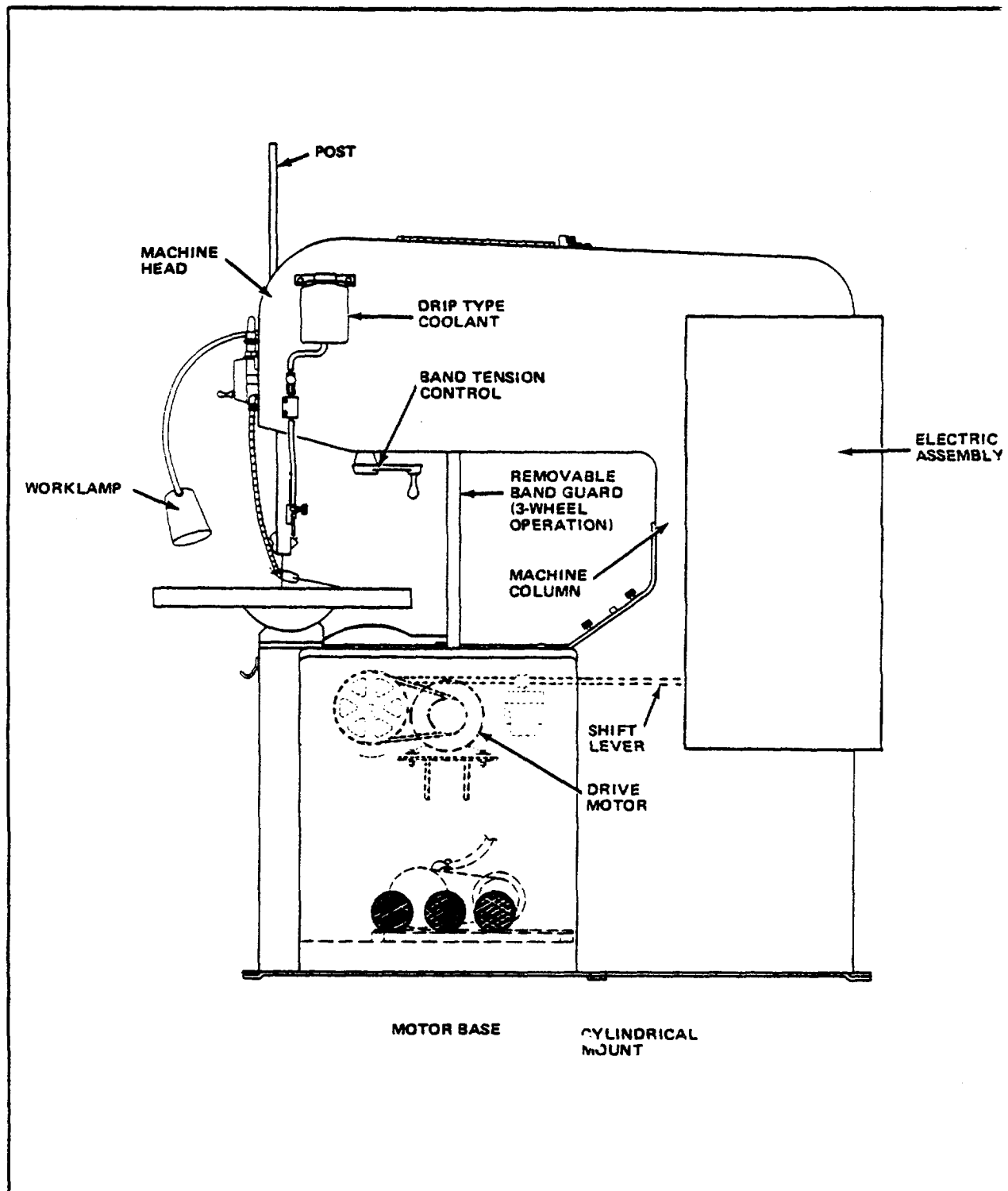

FIG. 5. CONTROLS AND FEATURES, REAR VIEW.

INSERT-TYPE SAW GUIDE ADJUSTMENT

- (1) Select guide blocks and inserts set marked for band width. Place right insert in milled slot. Tighten screw lightly so insert will slide in slot and hold its proper position when released. See Fig. 7.

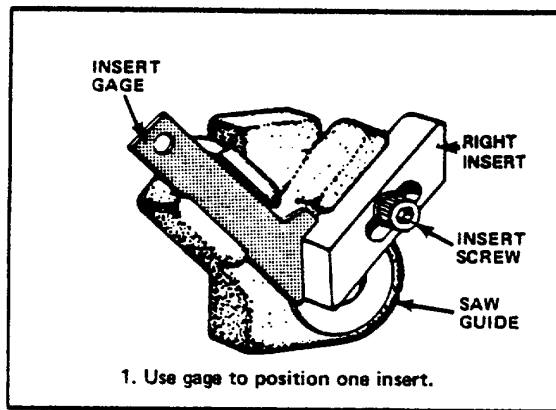

FIG. 7. POSITIONING RIGHT INSERT. UPPER GUIDE BLOCK SHOWN.

- (2) Select insert gage matching saw band. Place in slot. Adjust insert to fit exactly into gage notched end. Tighten insert screw. See Fig. 7.

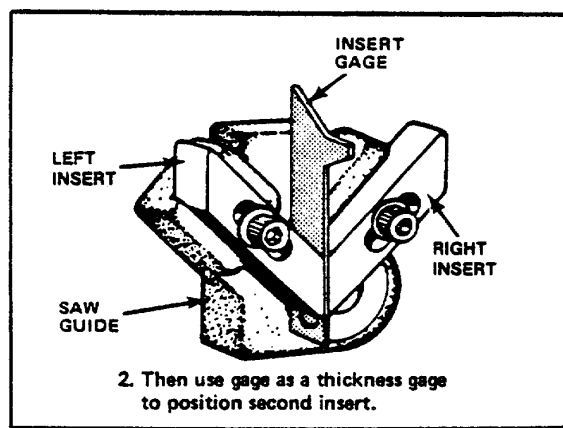

FIG. 8. POSITIONING LEFT INSERT. UPPER GUIDE BLOCK SHOWN.

- (3) Place left insert in slot. Tighten screw lightly. Place gage edgewise between both inserts. Lower insert until it rests against gage. Tighten screw. See Fig. 8.

NOTE

INSERT-TYPE GUIDES ARE RECOMMENDED FOR MAXIMUM BAND SPEEDS OF 1300 FPM (390 m/min) FOR PRODUCTION SAWING, OR UP TO 5000 FPM (1500 m/min) FOR OCCASIONAL SAWING, USE ROLLER GUIDES FOR CONTINUOUS SAWING OVER 1300 FPM (390 m/min).

BAND INSTALLATION

- (1) Open band wheel doors. Relax band tension. Remove post band guard. Loosen left saw guide insert. See Fig. 8.
- (2) Unlock saw slot bar located below table front edge. Move bar away from saw slot.
- (3) Place band carefully over wheels and between saw guide inserts. Band center should center on wheel's crown face. Apply proper band tension. Tighten saw guide inserts.
- (4) Move table slot bar back into position and lock. Re-install post band guard and close wheel doors.

BAND REMOVAL

- (1) Open band wheel doors. Remove post band guard and unlock saw slot cover. Move bar so that it does not cover saw slot. Release band tension.
- (2) Loosen saw guide inserts and carefully remove band. Slip band from wheels.

BAND TENSIONING

Band tension is applied by turning handwheel located below saw head. Tighten band to tension indicated on scale to right of handwheel. Correct tensions are given for bands 1/8-inch (3.2 mm) to 1 inch (25 mm). See Fig. 9.

Scale figures are recommended tensions. They are based on most commonly used gages and pitches. Reduce recommended tension when using bands with coarser pitch or lighter gage. Increase tension when using heavier bands.

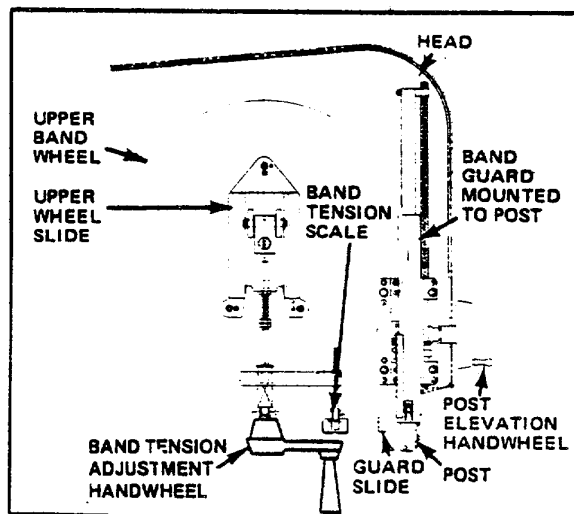

FIG. 9. BAND TENSION AND POST CONTROLS.

BAND TRACKING

The upper wheel can be tilted forward and backward a maximum distance of 3 inches (75 mm) to aid band tracking. A properly tracking band center should follow crowned rubber wheel tire centers. Perform the following tracking procedures with drive "off" and transmission in "neutral".

- (1) Open band wheel doors. Manually turn wheels and observe how band tracks on tires. Adjust wheel tilt if band does not track on tire centers.
- (2) Change wheel tilt by loosening lock nut and adjusting tilt knob until band rides tire correctly. See Fig. 10. Band's back edge should just touch saw guide back-up bearings.
- (3) Tighten lock nut.

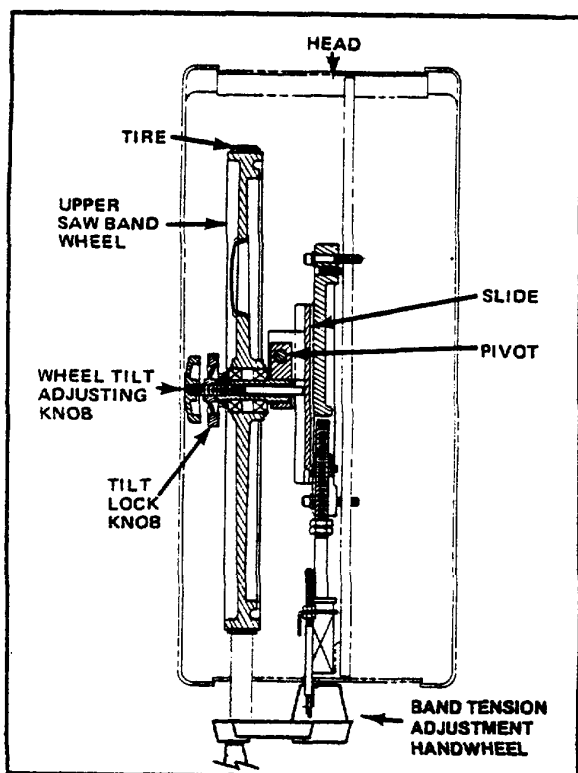

FIG. 10. WHEEL TILT ADJUSTMENT -SIDE VIEW.

POST ADJUSTMENT

Post elevation is adjusted manually by turning handwheel located on saw head. Turn wheel clockwise to lower post and upper saw guide; raise by turning counter-clockwise. See Fig 9. Always keep post and upper saw guide as close as possible to workpiece. Band guards should be locked in place at all times during sawing.

SPEED CONTROL

A transmission shift lever selects between two speed ranges. Each can be infinitely varied within its range by the band speed control located on machine front. Speed ranges are 50-300 fpm (15-90 m/min) and 850-5200 fpm (259-1585 m/min). Good practice recommends the following operator precautions:

- (1) Before shifting gears: turn band speed control to "TRANS. SHIFT POINT" (this releases the solenoid interlock) and make sure band is stopped. Turn drive wheel by hand when shifting to engage clutch.
- (2) Always turn band speed control to "slow" before stopping machine.
- (3) Do not attempt to force shift lever into place.

WORK TABLE

Standard machine work table measures 26 inches (660 mm) by 26 inches (660 mm).

All tables are drilled and tapped on front, rear, and right edges for accessory attachment. Table center disk is removable for changing saw bands, and for installing special-purpose center filing or polishing disks. See Fig. 11.

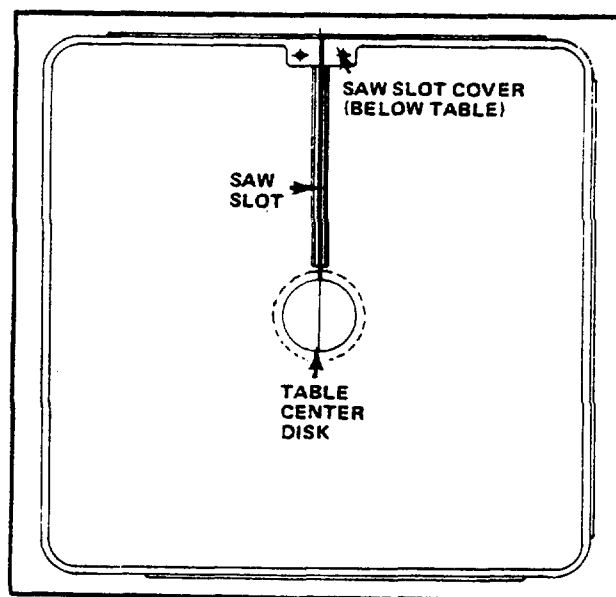

FIG. 11. TYPICAL WORK TABLE - TOP VIEW.

TABLE TILT ADJUSTMENT

The table can be tilted up to 10 degrees left or 45 degrees right by loosening the lock nut with provided wrench. Lock nut is reached through a frame opening under table on machine side near lower door latch.

Tilt table manually until desired angle is shown by pointer on trunnion-mounted calibrated scale. Lock table in position before sawing. See Fig. 12.

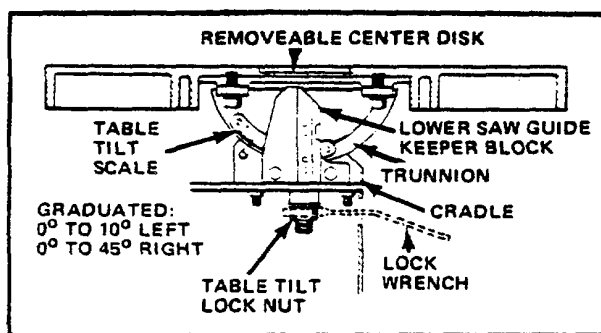

FIG. 12. TABLE TILT FEATURES.

CHIP REMOVAL

A wheel brush above lower wheel cleans chips from wheel tire. Chips are directed into a chip pan on some machines. Operator should remove pan and empty as necessary. On machines without chip pan, chips collect at machine base. It is important that operator occasionally open lower wheel door on such machines and scoop chips out.

Your machine may be equipped with a vane-type air pump and chip blower. Pump is driven by its own motor and delivers compressed air to chip blower on post. Flexible blower nozzle can be adjusted to remove chips from sawing area. See Fig. 13.

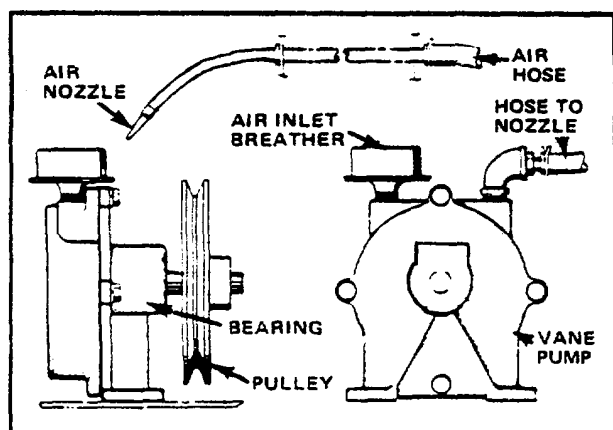

FIG. 13. AIR PUMP AND CHIP BLOWER - 3613-20 ONLY. 3812-2 OPTION

WELDING SAW BANDS

Complete instructions covering blade welding, operation and maintenance for the DBW-15 butt welder with flash grinder and blade shear are provided in a separate instruction manual. See Fig. 14.

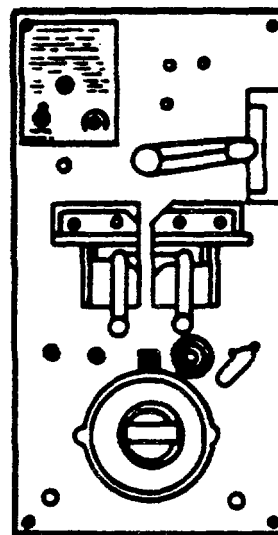

FIG. 14. DBW-15 WELDER, GRINDER - FRONT VIEW.

MANUAL CONTOUR SAWING

The standard machine can be used to manually cut contours. In addition, your machine may be equipped with one or more of the following contour sawing accessories: (1) Variable weight power feed, (2) Screw feed. They are described in more detail in the Accessories section.

Follow these precautions when contour sawing:

- (1) Use Job Selector recommendations for band selection, band speed, feed pressure, and coolant application type.
- (2) Reduce initial feed force to prevent blade damage when it suddenly enters an opening. Any band twisting or bowing means work is being fed too rapidly.

A hole is usually drilled in the workpiece when a sharp corner is to be cut. A corner can also be by-passed with a curve cut, leaving the remainder to be notched out later. See Fig. 15.

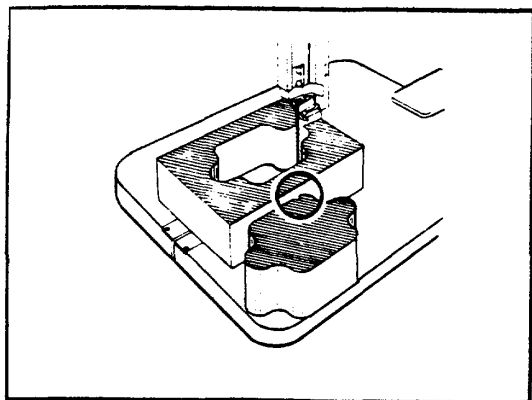

FIG. 15. STARTING HOLE FOR SHARP CONTOUR CUTTING.

Saw an internal contour by cutting band, drilling starting hole, running band through hole, then welding band. Use Disk cutting accessory if contour is a radius. See Fig. 24.

NOTE

You will insure a better weld on band which passes through workpiece hole by insulating the band from contact with workpiece or table.

Drilled starting hole's diameter is determined by band size. Widest possible band should be used for curve cutting. Attempting to cut too small a radius with too wide a band will cause it to bind. It may also cause lower wheel tire grooving.

Radii chart below shows minimum possible radii cuts with varying band widths. See Fig. 16. Use a heavy gage blade for heavy workpiece contour sawing. Radii chart recommendations are based on sawing relatively thin stock. Use a narrower saw band than recommended when sawing stock more than 1 inch (25 mm) thick.

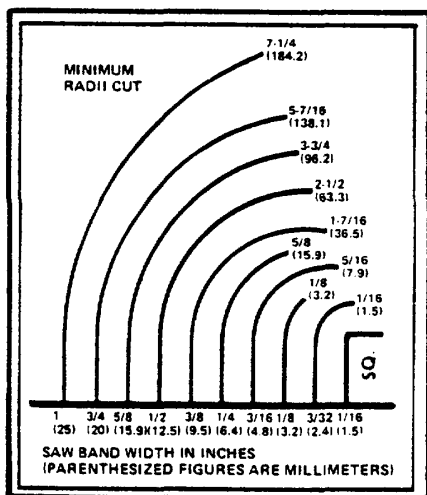
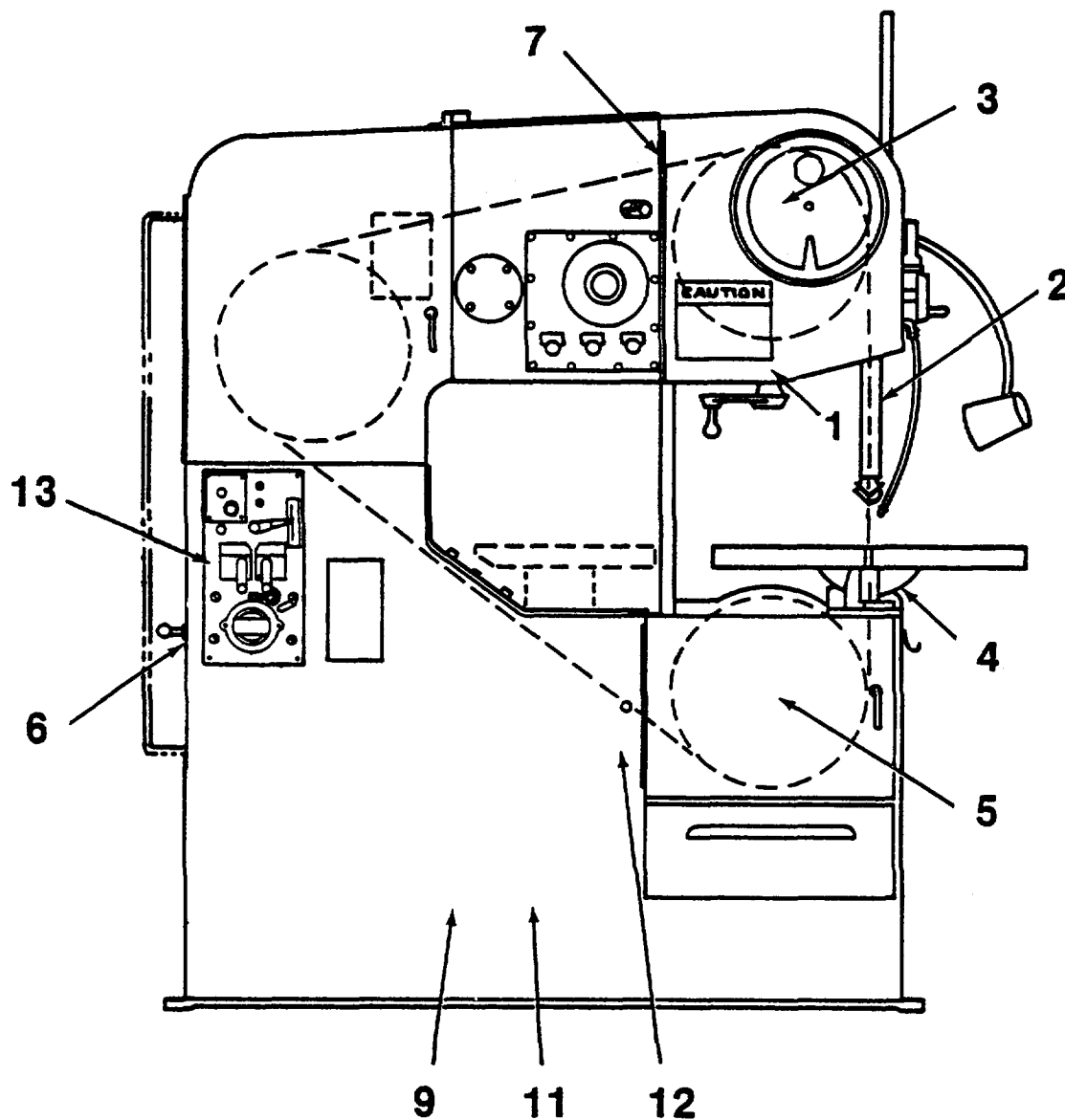

FIG. 16. MINIMUM RADII CUTS.

LUBRICATION

DIAGRAM AND CHART
(NEXT TWO PAGES)

LUBRICATION DIAGRAM



No's 8, 10 and 14 on chart not shown on diagram.

LUBRICATION CHART

LUBRICATION POINT NUMBER	LOCATION DESCRIPTION AND SERVICE RECOMMENDATIONS	LUBRICATION INTERVAL *	RECOMMENDED LUBRICANT
1	Sand Tension Screw and Bearing. Clean and apply oil.	MONTHLY	High quality, rust and oxidation inhibited, medium hydraulic and general purpose industrial oil. ASTM Grade No. 315.
2	Post, Post Elevation Screw and Gears. Clean and apply oil.	MONTHLY	
3	Upper Wheel Slide, Hinge and Tilt Screw. Clean and apply oil.	MONTHLY	
4	Table Trunnion. Oil tilt surfaces.	MONTHLY	
5	Transmission. 1 quart (0.95-liter) capacity. Proper oil level must be maintained. Drain and refill yearly or when required.	AS REQUIRED	
6	Transmission Shift Linkage and Interlock. Clean and apply oil as required.	AS REQUIRED	
7	Miscellaneous, Hinges, Pivot, etc. Clean and apply oil as required.	CHECK MONTHLY	
8	Accessory Equipment as Supplied. Keep clean and apply oil as required to maintain proper function and reduce wear, corrosion, etc.	CHECK MONTHLY	
9	Air Compressor (Optional). Proper oil level must be maintained. Drain and refill every 3 months. Keep crankcase and air intake filter clean.	CHECK WEEKLY	(For 80 degrees F and above). High quality, rust and oxidation inhibited, medium hydraulic and general purpose industrial oil ASTM Grade No. 465.
10	Grease Fittings and Miscellaneous applications (Optional).	CHECK MONTHLY AS REQUIRED	Premium quality, multi-purpose, lithium base, EP (extreme pressure) grease. NLGI Grade No. 2
11	Air Pump (Optional). Remove air intake filter. Feed lubricant into opening while pump is in motion. Keep air filter clean.	CHECK MONTHLY AS REQUIRED	Dry, powdered lubricating graphite (natural or manufactured). graphite lubricant.
12	Electric Motor(s).	Lubricate as required per manufacturer's recommendations.	
13	DBW-15 Welder	Lubricate as required per DBW-15 Instruction Manual.	
14	Drip or Mist Coolant Tank (Optional). 1 quart (0.95 liter) capacity. Keep filled.	CHECK DAILY AS REQUIRED	Premium quality, saw band coolant and lubricant. cutting fluids and/or oils.

Lubrication intervals are based on an 8-hour day, 40-hour week. Lubricate more often when required.

MAINTENANCE

HEAD ASSEMBLY

Wipe oil on post occasionally. Then run post up and down several times through slide block. Upper wheel slide and band tension screw should be oiled monthly. Wheel bearings are sealed and lubricated for life. See Fig. 17.

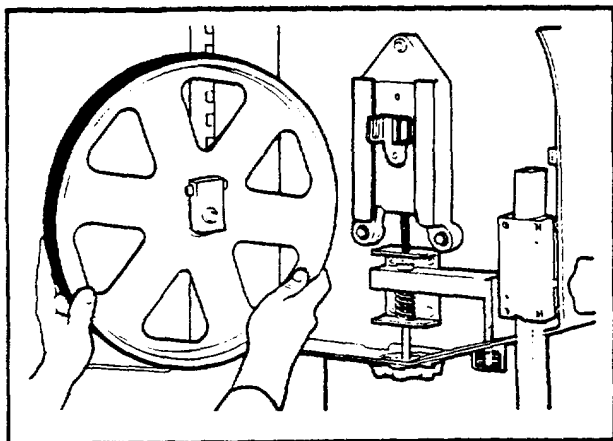

FIG. 17. UPPER WHEEL REMOVED TO SHOW HEAD ASSEMBLY DETAIL

CHIP REMOVAL

A wheel brush is mounted above lower wheel to clean chips from wheel tire. If worn, and gap between brush and wheel tire is greater than 0.015-inch (0.38 mm), loosen adjusting screws and adjust brush. Replace as required. See Fig. 18.

If your machine is equipped with a chip collecting pan, it should be emptied when necessary.

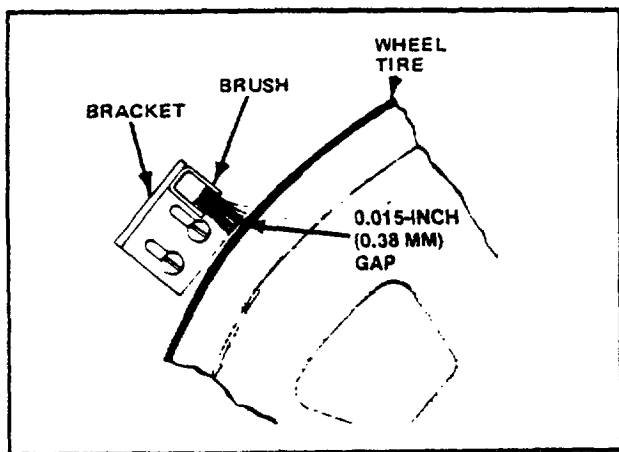

FIG. 18. LOWER WHEEL CHIP BRUSH.

REPLACING WHEEL TIRES

Replace worn tires by loosening them from wheel with a screw driver, or other flat tool. Stretch until tire can be removed. Scrape wheel clean and apply fresh cement before installing new tire.

TRANSMISSION

Any rough operation, vibration, loud or unusual noises should be investigated immediately. Check for seal leaks around shafts. It is recommended that a faulty transmission be returned to factory for repair. Correct new transmission installation is extremely important because careful alignment is necessary.

DRIVE BELTS

Drive belts on the transmission and compressor pulleys may stretch slightly after initial use. Tighten transmission belt by loosening drive motor foot bolts. Slide motor to tension belt; then tighten bolts. Tighten compressor belt in a similar fashion. Figs. 19 and 20.

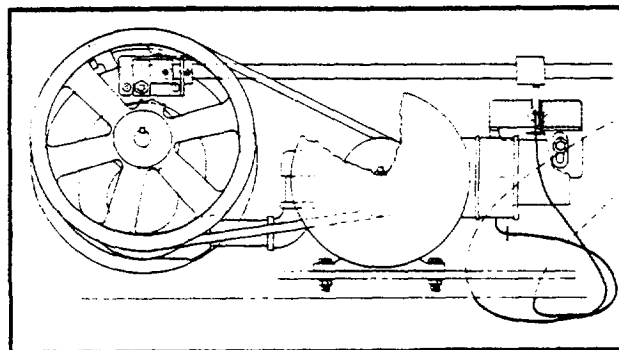

FIG. 19. DRIVE BELTS ASSEMBLY.

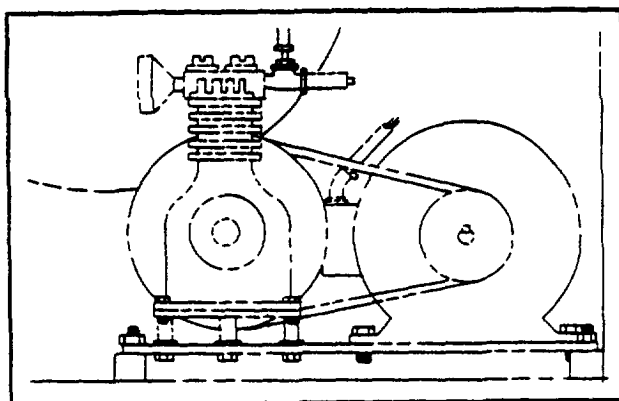

FIG. 20. AIR COMPRESSOR ASSEMBLY.

SAW GUIDES (Insert-Type)

Roller Back-Up Bearing: Bearings are sealed and packed for life with a special lubricant. They are replaced by removing snap ring; then pulling out bearing and shaft. New bearings are easily installed with a light press fit.

DRIVE MOTOR

Follow manufacturer's maintenance instructions for main drive motor. They are on a tag attached to motor.

TROUBLE SHOOTING**MACHINE WILL NOT START**

- (1) Check band tension limit switch (if provided).
- (2) Check band drive motor starter reset. Starting and stopping machine a number of times in quick succession will cause an overload to trip starter heater. Push reset button after locating and correcting trouble.
- (3) Check fuses located behind DC circuit board.

MACHINE VIBRATION

- (1) Band wheels have become unbalanced.
- (2) Drive belt is unbalanced.
- (3) Machine base is not shimmed properly.

SAW BAND VIBRATION

- (1) Worn blade teeth. (Inserts too wide for blade will damage set teeth).
- (2) Workpiece scale not removed.
- (3) Blade too wide for radius being cut.
- (4) Incorrect band or insert alignment.
- (5) Incorrect feed force or band speed.
- (6) Coolant not being applied evenly to both band sides.
- (7) Upper post saw guide not close enough to workpiece.
- (8) Incorrect saw band tension.
- (9) Check for loose post. Adjust cover plate, if necessary.

EXCESSIVE INSERT AND BLADE WEAR

- (1) Inserts adjusted too tightly on blade.

- (2) High band speed causing friction. Use Saw-Eez, or coolant, to lubricate band. Use roller saw guides, if possible.
- (3) Roller guide rollers adjusted too tightly on
- (4) Chip brush worn or not properly adjusted. This allows chips to stay on wheel.
- (5) Back-up bearing needs replacement.

PREMATURE SAW BAND DULLING

- (1) Saw band not being properly broken in on first few cuts. Reduce feed pressure and speed on first cuts.
- (2) Band speed too high, causing abrasion.
- (3) Saw band pitch too coarse.
- (4) Feed pressure too light.
- (5) Coolant not covering saw band.
- (6) Cutting rate is too high.
- (7) Faulty material: heavy scale, inclusions, hard spots, etc.
- (8) Saw band vibration.
- (9) Chipped tooth lodged in cut.
- (10) Chip welding.
- (11) Inserts too wide for blade width, allowing them to hit set teeth. Listen for clicking sound during band operation.

BAND SLIPS FROM WHEELS

- (1) Upper wheel not correctly aligned. Band should track near wheel tire's center.
- (2) Too much coolant, or slippery coolant, being used.
- (3) Incorrect initial machine alignment.
- (4) Improper guide block used.

SURFACE FINISH ON WORK TOO ROUGH

- (1) Saw guide insert worn. Re-adjust or replace.
- (2) Saw band speed too low.
- (3) Saw band pitch too coarse.
- (4) Feed is too heavy.
- (5) Machine vibration.

FILE BAND BREAKS

- (1) Feed force is too high.
- (2) Wrong file band type being used.

POOR BAND FILING FINISH

- (1) Feed force is too high.
- (2) File band not correctly assembled.
- (3) Band tension is too high. Set for same as 1/8-inch (3.2 mm) wide carbon band.

ACCESSORIES

VARIABLE WEIGHT POWER FEED

The variable weight power feed allows operator to use both hands for guiding work being pulled into saw band. See Figs. 21 & 22.

Weight position on beam determines feed rate and pressure. Weight position is set by a handwheel. The beam is raised initially by pushing foot pedal. Feed force exerted against blade ranges from 0-80 pounds (0-36 kg). Turn handwheel on side of base clockwise to reduce pressure and feed rate. Use heavy feed force when sawing with wide bands and lighter feed forces for narrower bands.

Feed force less than 10 pounds (5 kg) is achieved by partially restraining pedal. Lighter feed forces are required if workpiece is significantly thicker. Release pressure and stop feed by removing foot from pedal.

Where a cut has longer than 10 inch (255 mm) maximum feed distance, bring weight back into position at bottom of stroke by pressing pedal into notch. Then remove work holding chain slack.

CAUTION
PEDAL SHOULD REMAIN in ITS UPPER POSITION WHEN NOT in USE. THIS GUARDS AGAINST OPERATOR AND MACHINE INJURY SHOULD PEDAL BECOME ACCIDENTALLY DISLODGED.

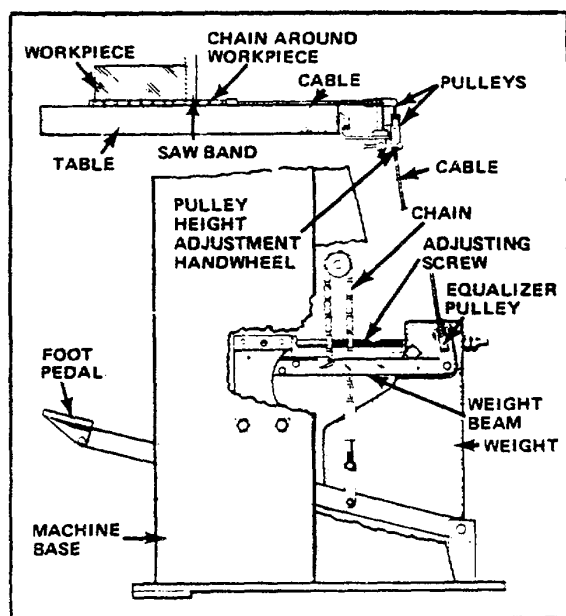

FIG. 21. VARIABLE WEIGHT POWER FEED FEATURES.

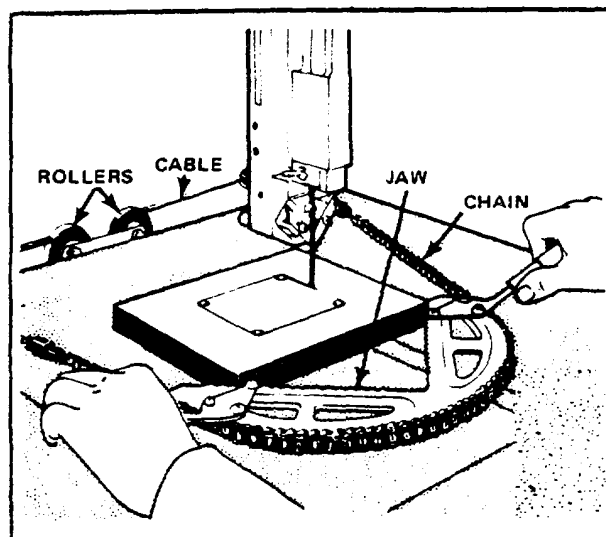

FIG. 22. WORK HOLDING JAW.

NO. 1 ALL-PURPOSE CUT-OFF

Used with variable weight power feed for ripping, cutting-off, and mitering functions. It allows operator to notch, square, rip, or miter rods, tubes, bars, channels, rails, and irregular shapes with accuracy. See Fig. 23.

- (1) Mount table guide and guide spacer. Slide unit along guide and square miter bar with table slot. Place graduation scale at "zero" marking.
- (2) Lock unit in desired position with set screw.
- (3) Use handwheel for manual operation.
- (4) Change from manual to automatic feeding by disengaging feed screw with split nut lever. Fasten power feed chain around miter head collar top.

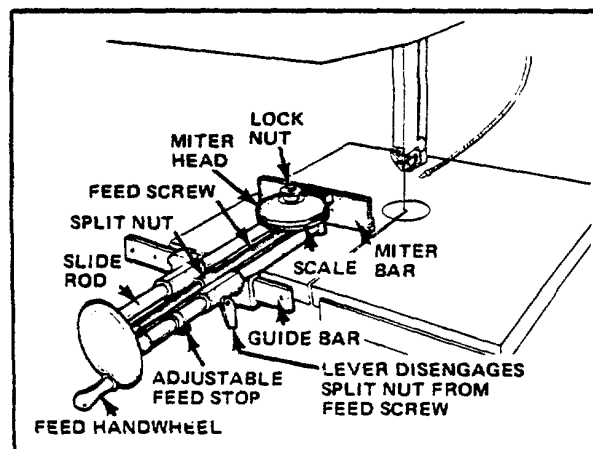

FIG. 23. NO. 1 ALL-PURPOSE CUT-OFF, RIPPING, MITERING.

DISK CUTTING

Used to cut internal or external true circles from 2-1/2 inches (65 mm) to 30 inches (760 mm) diameter. See Fig. 24.

- (1) Place flat washers under screws and bolt bracket to post.
- (2) Lower post until saw guides are approximately 3/8-inch (10 mm) above table.
- (3) Loosen fine adjustment and arm clamp bolts. Move center pin to approximate distance or radius to be cut. Tighten fine adjustment clamp bolt.
- (4) Centering pin's center must be perpendicular to the saw band cutting edge. Do this by placing a square against saw slot side with square blade against saw tooth tip. Loosen vertical adjustment clamp bolt. Line up centering pin with square's blade edge. Clamp tight.
- (5) Make final radius adjustments with fine adjustment wheel. Tighten arm clamp bolt. Tighten radius arm clamp while making sure center pin is square to table. Raise or lower saw guide post to adjust unit for work thickness.

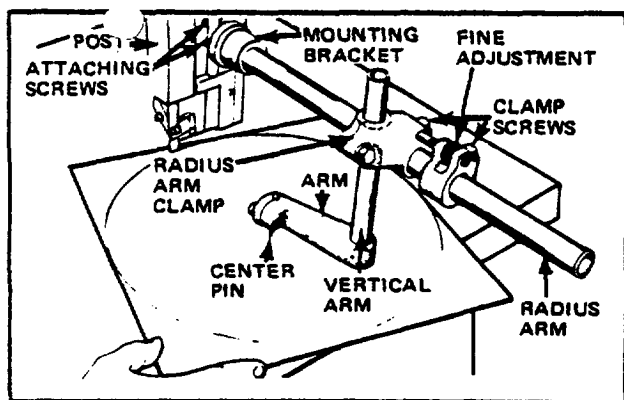

FIG. 24. CUTTING RADIUS WITH DISC CUTTER.

SCREW FEED

Screw feed is used for precision heavy work contour sawing. Mount swivel in table front bracket. Adjust screw to any point within its 12-inch (305 mm) movement by lifting swivel top release knob. See Fig. 25.

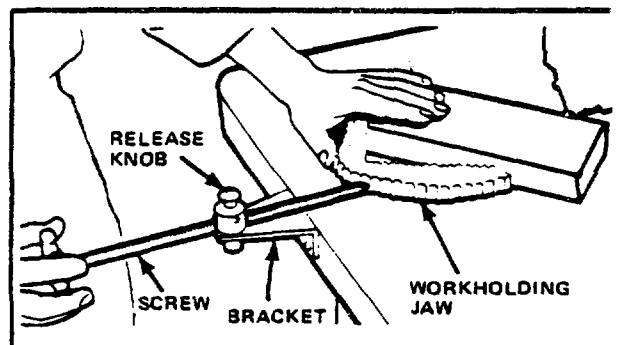

FIG. 25. SCREW FEED.

SPIRAL SAW BAND GUIDES

Required when using spiral bands having a 360 degree cutting edge. These bands are for sawing intricate contour patterns without turning workpiece. It can be used on such materials as plastics, woods, and light gage metals. Set up as follows:

- (1) Install saw guides and band. Proper tension is same as for a 1/16-inch (1.6 mm) wide carbon saw band. See Fig. 26.
- (2) Adjust upper wheel tilt until band rides freely in roller grooves. Rollers have ball bearing mountings grooved for accurate band guidance.
- (3) Each guide has an eccentric shaft roller. Adjust eccentric by loosening guide block set screw. Turn eccentric with a screwdriver until band rides both roller groove bottoms. Band cutting edges should be facing down to table when band revolves.

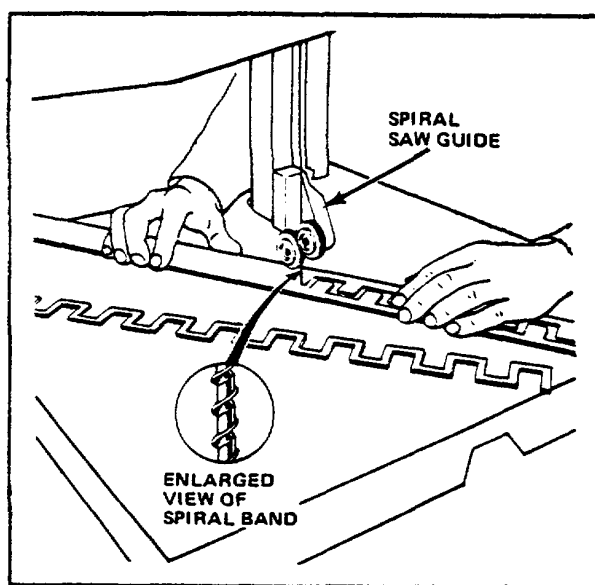

FIG. 26. SPIRAL SAW BAND GUIDES.

ROLLER SAW BAND GUIDES

Use roller guides for continuous high speed sawing. Adjust them as follows:

- (1) Install guides on upper post and lower keeper block. See Fig. 27.
- (2) Select correct rollers for band width. Place one back-up roller and one side roller in each block.
- (3) Install band and adjust tension.

- (4) Bring rollers into contact with band by turning eccentric shaft with a screwdriver.

NOTE

Bearings will overheat if rollers are too tight against band. Band may wobble if rollers are loose.

- (5) Tighten roller lock screws so eccentric shaft will not turn.

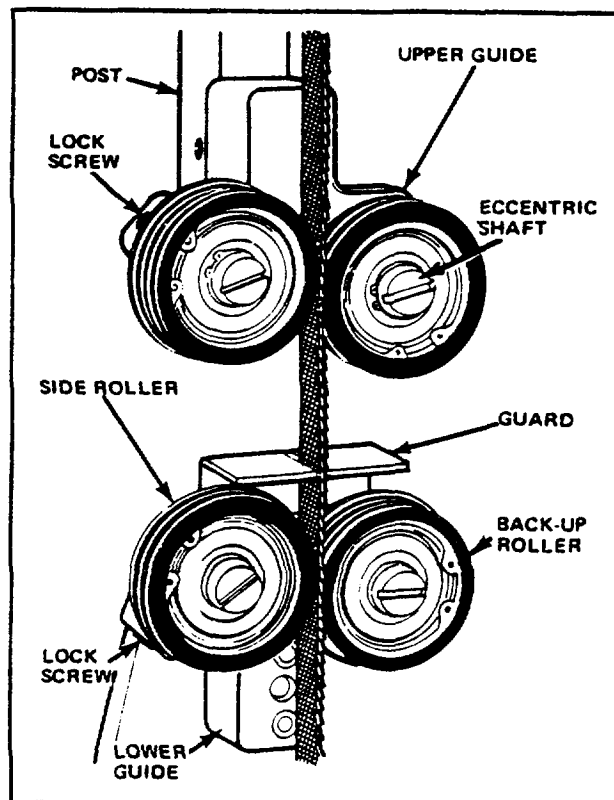

FIG. 27. ROLLER GUIDES ALLOW CONTINUOUS HIGH-SPEED SAWING.

INSERT-TYPE SAW GUIDES

These high-speed, insert-type saw guides are designed for sawing speeds up to 5000 fpm (1500 m/min). Be sure inserts match band width. Guides are installed and adjusted like regular insert-type saw guides.

If bearings need replacing, remove snap ring. Pull out carbide bearing shaft and remove bearings. Install new bearings with a light press fit, insert carbide bearing and snap ring. Bearings are sealed and packed for life with a lubricant.

90° SAW BAND GUIDE BRACKETS

The 90 degree saw guide brackets permit cutting material greater in length than the machine's regular throat capacity. Mount brackets and correct saw guides. See Fig. 28. Install band so it is twisted 90 degrees when passing through inserts. Operate machine at speeds under 1500 fpm (450 m/min).

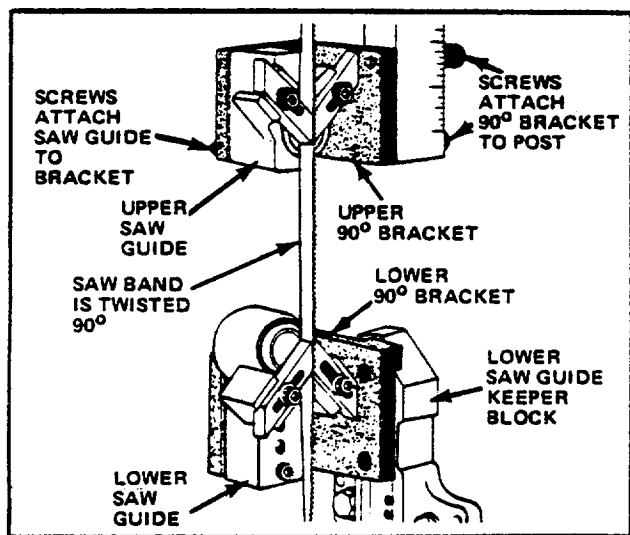

FIG. 28. 90° SAW SAND GUIDE BRACKETS.

RIP FENCE

Install by squaring fixture so it is in line with table slot. Be certain band is not worn on one side before attempting a long cut. This will cause work to wander relative to rip fence guide bar. See Fig. 29.

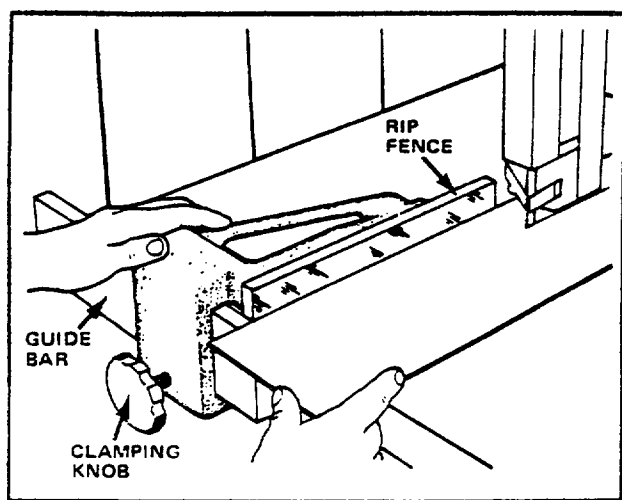

FIG. 29. RIP FENCE.

NO. 2 CUT-OFF & RIPPING (Side Mount)

Make sure mitring bar is in even contact with table surface. Place a combination square in table slot to check alignment and set mitring bar at various angles. See Fig. 30.

When not in use, swing unit up, to the right, and down on slide rod so it hangs below table.

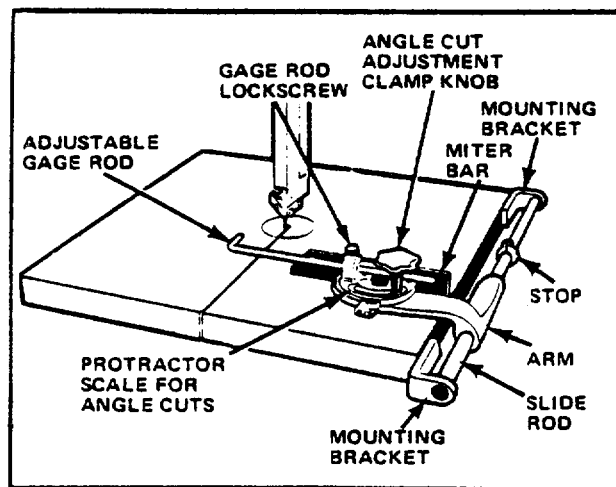

FIG. 30. NO. 2 CUT-OFF AND RIPPING (SIDE MOUNT).

UNIVERSAL VISE

Applies work-holding pressure needed for accurate production cut-off work between 0-45 degrees. An adjustable cut-off gage assembly mounts in a T-slot on the table's left side to allow duplicate cut-off operations for production runs. Work is rapidly clamped and unclamped by a lever-operated eccentric. Table T-slots allow vise to be removed quickly and easily. See Fig. 31.

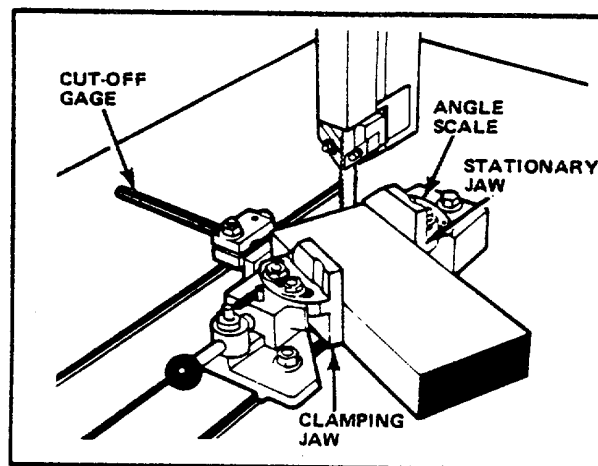

FIG. 31. UNIVERSAL VISE.

UNIVERSAL CALIBRATED WORK FIXTURE

This accessory clamps to the table, can be set up for straight or angle cut-off, and holds the workpiece in position while it is moved into the saw band. For straight sawing, place fixture on table at required distance from band. Loosely install T-nuts and screws. Square fixture to table by lining up one moveable stop edge with one table slot edge. Tighten screws. Saw kerf into bar 1/16 to 1/8 inch (1.5 to 3.2 mm) deep to allow cutting completely through workpiece. Set adjustable table stops to prevent deeper sawing into work bar after cut completion.

For angle sawing, remove right T-nut and screw. Loosen left screw, turn fixture to desired angle, and tighten left screw. Mount collar (behind bar) loosely on T-nut with socket-head screw. Bring collar snugly against bar and tighten screw. See Fig. 32.

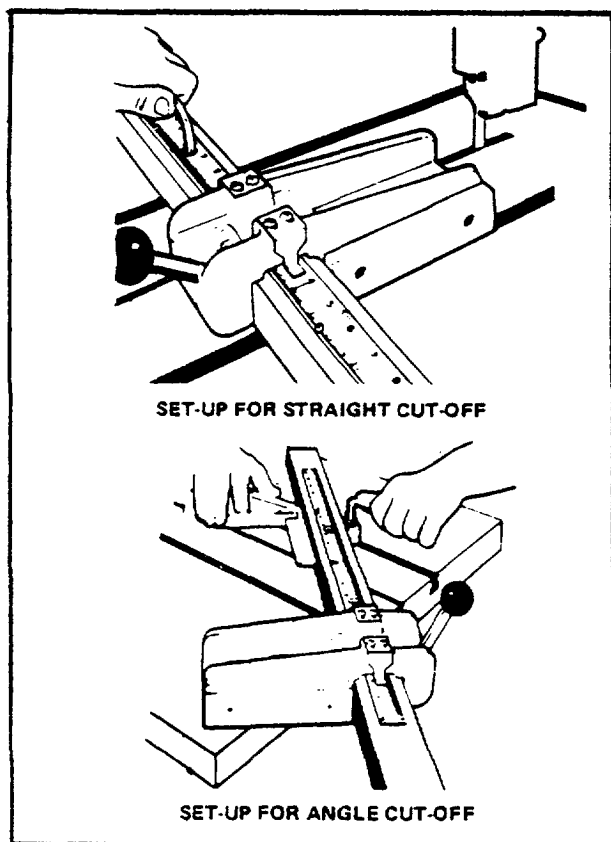

FIG. 32. UNIVERSAL CALIBRATED WORK FIXTURE.

MIST COOLANT APPLICATOR

Coolant is delivered from a 1-quart (0.95-liter) bottle on

machine head back to drip applicator valve with sight glass. Coolant next enters manifold and is directed into a nylon tube which passes through flexible air tube. Air and coolant are mixed at nozzle end to form a fine mist. Bend applicator tube to direct mist stream onto blade teeth and work.

Regulate mist with drip applicator valve. Count drops visible through sight glass. Normal mist adjustment produces approximately one coolant drop per second. See Fig. 33. Check for a fine, consistent mist by directing stream onto a metal surface. Intermittent stream with coolant spurts generally indicates a manifold air leak. Check all joints.

Clean nozzle and coolant bottle when necessary. Replace nylon center tube by disassembling flexible tubing. Insert new center tube. Make sure all joints are sealed and tight. Coil applicator tube a few times, and trim excess nylon so that it is flush with nozzle end.

See Lubrication Chart for recommended coolant products. Clogging may occur if wax-based or other coolants are used.

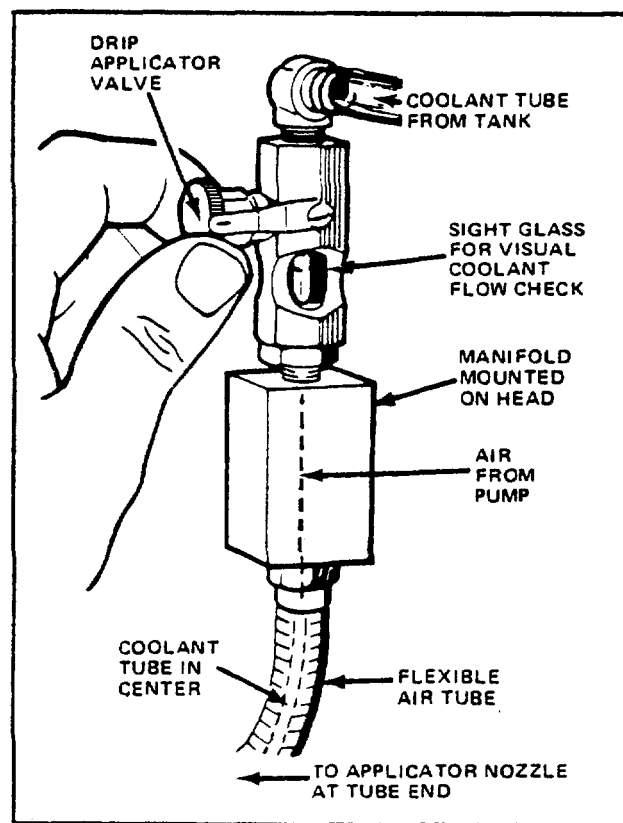

FIG. 33. ADJUSTING MIST COOLANT.

DRIP-TYPE COOLANT APPLICATOR

The 1-quart (0.95-liter) coolant container and holding bracket mount to head side panel. Lubricator fastens to post with a set screw. Lubricator slide rod adjusts to blade widths. See Fig. 34.

Adjust applicator so copper tube outlet just touches saw tooth edges. This will assure lubricant flow to both saw sides. Adjust sight feed valve to deliver no more than 10 drops per minute.

NOTE

Too much coolant will cause saw band slippage on wheels. Use sparingly.

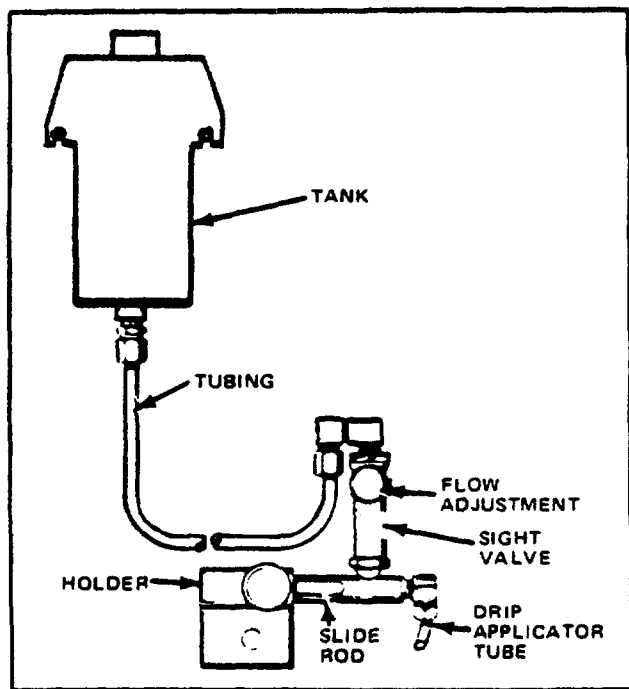

FIG. 34. DRIP COOLANT APPLICATOR FEATURES.

AIR PUMP & CHIP BLOWER

The vane-type air pump is belt-driven by its own motor. Compressed air from pump is delivered to chip blower mounted on machine post. Adjust flexible blower nozzle to remove chips from sawing area. See Fig. 35.

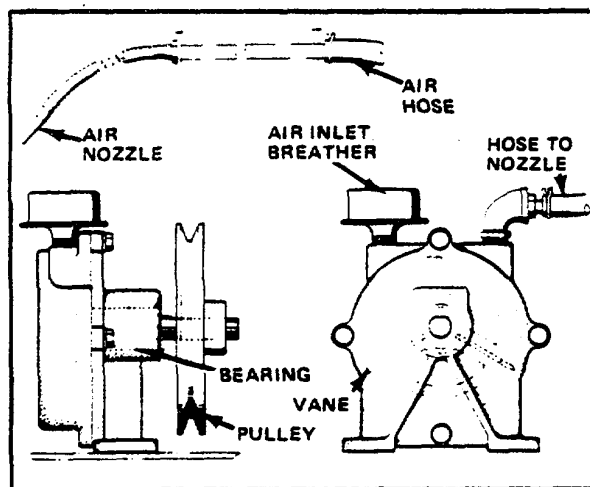

FIG. 35. AIR PUMP AND CHIP BLOWER.

BALL TRANSFER STRIPS

Your machine may be equipped with 6 detachable ball transfer strips to make heavy workpiece moving easier. 2 center strips are doweled, and attached to table with socket head screws. The other 4 strips are moveable during sawing. See Fig. 36.

Work height is reduced by 1-1/2 inches (40 mm) when ball transfer strips are attached to table.

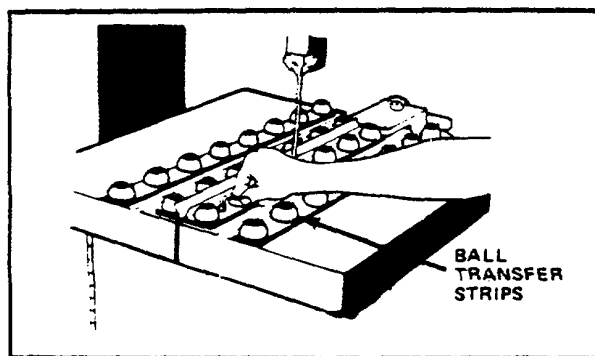

FIG. 36. BALL TRANSFER STRIPS.

HEAVY WORK CLAMPS

Heavy work clamps are used for contour sawing heavy materials, and stacked parts. Clamps have a ball bearing base, and a 4-inch (100 mm) clamping capacity. See Fig. 37.

A special center block is placed in table center. Saw it to leave blade travel path or kerf. It's important to use this center block when cutting stacked parts.

Clamp material and square work with blade by using table tilting device. Connect power feed chain to mesh with clamp gear teeth.

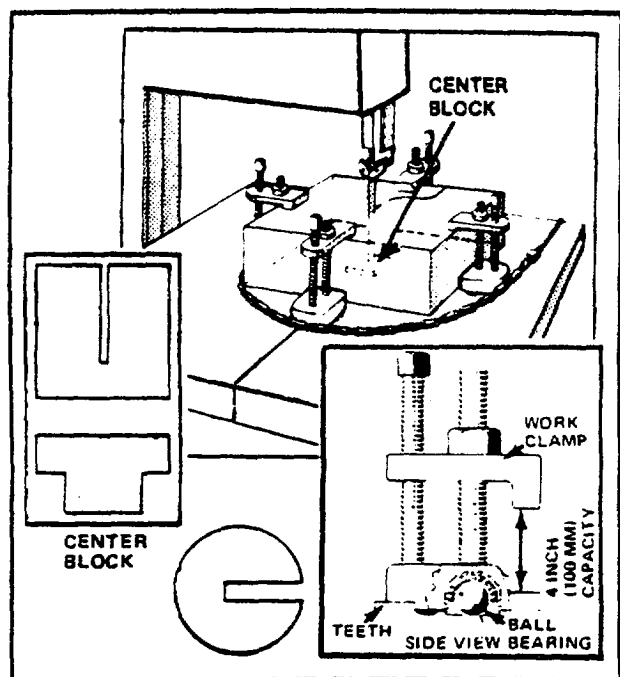

FIG. 37. HEAVY WORK CLAMPS.

HEAVY WORK SLIDES

Slide bars contain ball bearings, and a separate center block to support material at sawing point.

Insert special center support block in table center disk. Saw center block so a blade travel path or kerf is made. This provides solid sawing point contact between work and feed table surface. See Fig. 38.

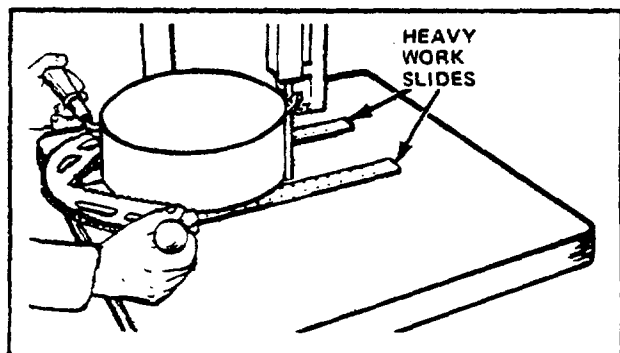

FIG. 38. HEAVY WORK SLIDES.

WORK LIGHT & MAGNIIFIER

The operator can magnify cut area during delicate sawing procedures. This is done with a magnifying lens which fits over work light front portion. A protective lens cover which prevents scratching should be placed around magnifier when not in use. See Fig. 39.

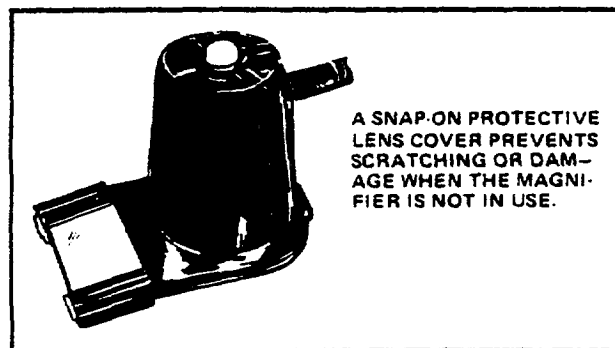

FIG. 39. WORK LIGHT WITH MAGNIFYING LENS.

CHIP PAN

Your machine may be equipped with a removable chip pan below lower wheel door. This pan catches chips removed from lower wheel by chip brush. Remove pan and clean out chips When necessary.

SPARK GUARD FOR FRICTION SAWING

Spark guard attaches to band guard with machine bolt. Always use it when friction sawing. See Fig. 40.

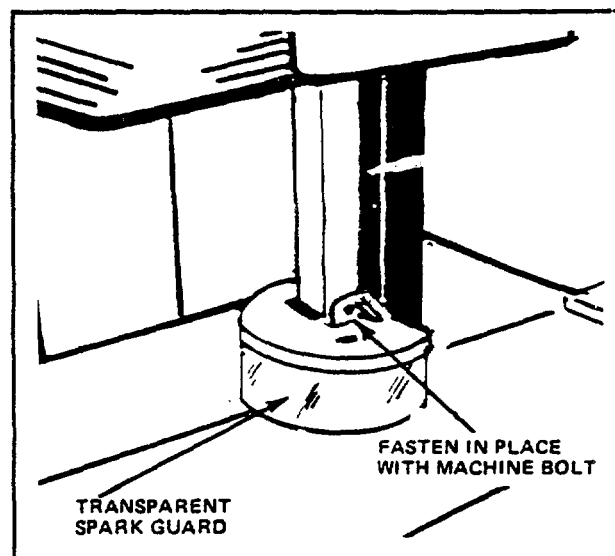

FIG. 40. SPARK GUARD FASTENED TO UPPER SAW GUIDE.

SECONDARY (AUXILIARY) TABLE

The secondary table measures 17 by 19 inches (430 by 480 mm) and is used when straight through sawing of material sections longer than 35-112 inches (905 mm) is desired. This table does not tilt and can be used only when the two-wheel band guard has been removed. As shown in Fig. 41, the table is mounted to a support unit which attaches to the machine frame behind the primary table.

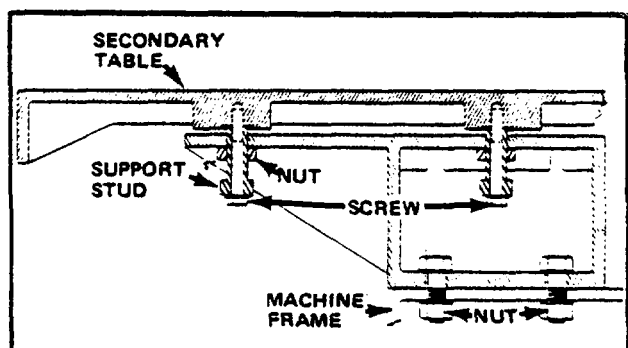

FIG. 41. SECONDARY TABLE.

DUST SPOUT

A dust spout may be provided on your machine just below lower saw guide. A dust-collection tube can be attached to this spout.

WELDER

Instructions covering the DBW-15 welder are provided by a separate instruction manual included with machine shipment.

BLADE SHEAR

Mounted on machine column, this tool is used to cut and trim bands square preparatory to band butt welding.

ETCHING PENCIL

Electric power for this tool is supplied by butt welder. If it is used for marking on metal.

WORK TABLE OPTION

Your machine may be equipped with a factory-installed 30-inch (760 mm) square work table replacing the standard 26-inch (660 mm) square table.

SLIDING TABLE (AIR FEED)

A lever controlled air feed system allows this table forward or back movement under light hand pressure. Table locks permit loading and positioning heavy work pieces. Maximum table travel is 12 in. (305 mm). Table tilts 6° left, 45° right. Shop air at 80 psi (5.62 kg/cm²) is required.

SUPPLY CABINET (Shipped Unassembled)

The supply cabinet provides orderly, safe storage for saw band coils, welded saw bands, file bands, and polishing bands. It is also useful for storing component parts and removable machine accessories. See Fig. 42.

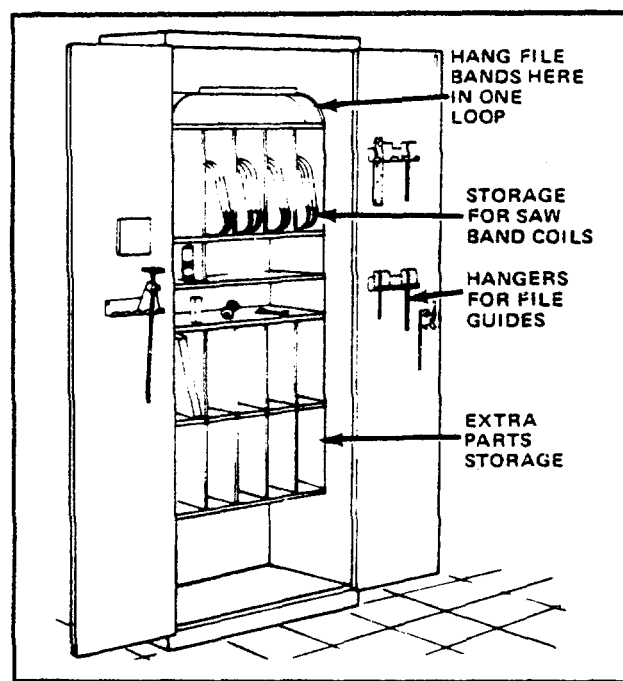

FIG. 42. SUPPLY CABINET.

BAND FILING

Machine Set-Up:

Before internal or external filing may begin:

- (1) Remove saw band, table center disk, post band guard, and saw guides. Mount file guide support to lower keeper block. Make sure proper file band slot width is used. See Fig. 43.
- (2) Lower upper post to proper work thickness. This should not exceed 2 inches (50 mm) for 1/4-inch (6.4 mm) band, 4 inches (10 mm) for either 3/8-inch (9.5 mm) or 1/2-inch (12.5 mm) bands. Longer guides that permit greater thickness filing are available as accessories.

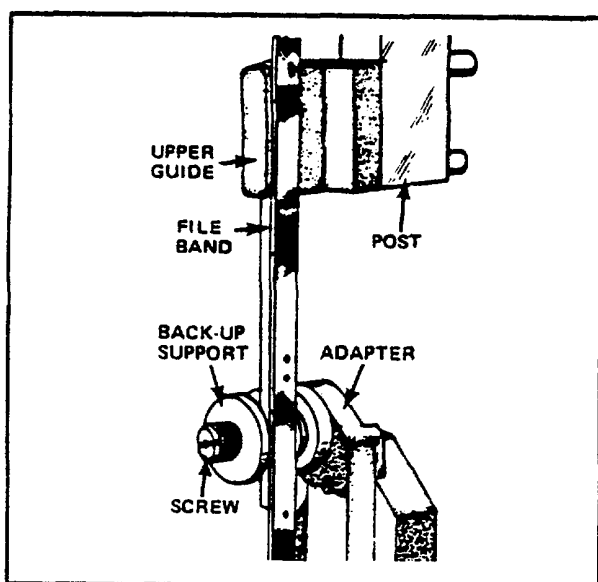

FIG. 43. FILE GUIDE INSTALLATION.

- (3) Install upper file guide and lock it firmly to post with knurled thumb screws. install special table center filing disk. See Figs. 44 and 45. Insert one band end through table center disk. File cutting edges should face downward.

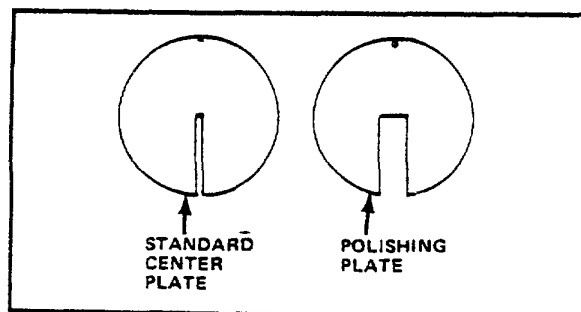

FIG. 44. STANDARD TABLE CENTER PLATE AND POLISHING PLATE

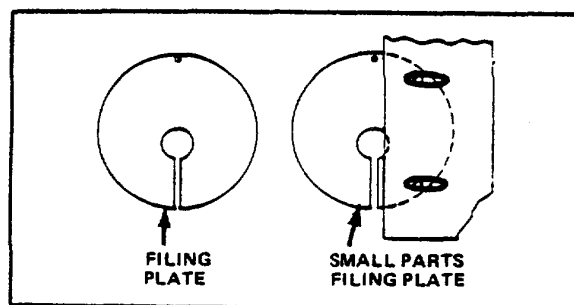

FIG. 45. SPECIAL TABLE CENTER FILING PLATES

File Band Joining:

Place one band end in each hand. Hold yellow painted end in left hand. Depress spring steel band tip in right hand with yellow segment lock rivet in left hand. Slip rivot head into slotted hole. Slide rivot head into slot's small end. Straighten band. Allow spring steel end to snap over dowel. See Fig. 46. Band ends must be flush before operating.

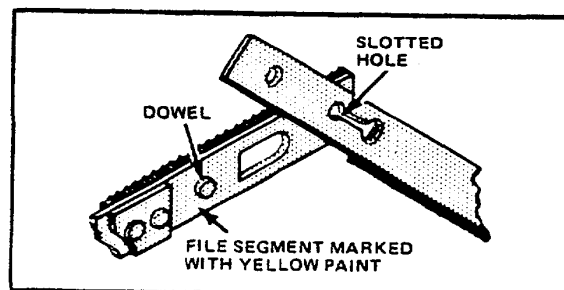

FIG. 46. JOINING THE FILE BAND.

File Band Tracking and Tensioning:

Align band on wheels in same manner as for saw band tracking. Tilt upper wheel, if necessary, to make band run on wheel crown. See Fig. 47. Band should run freely over file guide supports when properly tracked.

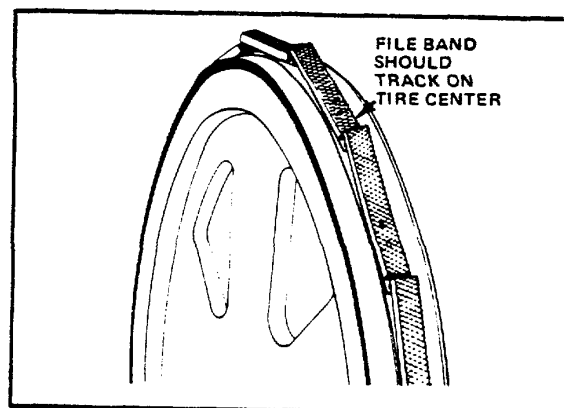

FIG. 47. FILE BAND TRACKING.

Tension should be same as that used for 1/8-inch (3.2 mm) wide carbon saw band. Most accurate filing can be obtained with light band tension.

NOTE: Excess band tightening should be avoided.

Shift machine speed control to "low" gear and "start" drive motor.

Filing Operation:

Turn Job Selector dial to "Band Filing" section. Correct band velocity and feed pressure are listed for many metals and materials according to work thickness. For internal filing, release tension, separate band, and run it through workpiece opening. Then reassemble.

Correct speed and pressure combination will produce curled chips. Best filing speeds are between 80-150 fpm (24-45 m/min).

Keep files clean. Do not file when teeth are loaded.

If your machine is so equipped, a coolant such applied in light mist form can be used to cool work and clean file during operation. Filing can be performed without coolant if there is difficulty in seeing layout lines.

Internal Filing:

Release tension, separate band. Hold band at joint with both hands (yellow segment in left hand). Bend joint to approximately 12-inch (305 mm) radius to expose joint slot. Depress yellow band's front end with left forefinger. Use right thumb and forefinger to disengage dowel. Slide lock rivet to slot's open end and remove. Run band through workpiece and join. Apply tension and check alignment. See Fig. 48.

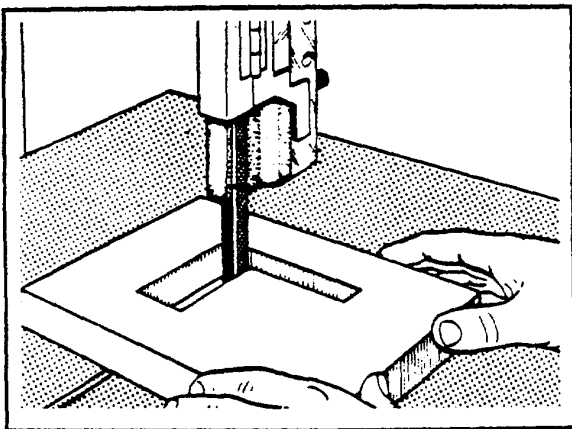

FIG. 48. INTERNAL BAND FILING.

File Band Storage:

Clean band with file card. Coil band into no more than three loops. Store preferably in a supply cabinet. Here bands are looped in a 16-inch (405 mm) radius with ends hanging in a compartment. (See supply cabinet sketch in this section).

FILE GUIDES

Standard and long file guide sets are available for the 26-inch (660 mm) and 30-inch (760 mm) square tables. Each set has a file guide back-up assembly, plus 1/4-inch (6.4 mm), 3/8-inch (9.5 mm), and 1/2-inch (12.5 mm) guides.

BAND POLISHING

Bands are mounted over wheels in same manner as saw bands.

- (1) Remove table center disk. Mount polishing band guide support to lower adapter. See Fig. 49. Lower post to 4 inches (100 mm) from table. Mount polishing band guide to post with two thumb screws. Mount and track polishing band on wheels in same manner as file bands. Correct polishing band tension is that used for a 1/16-inch (1.5 mm) wide carbon saw band. Install special table center adapter plate. See Fig. 50.

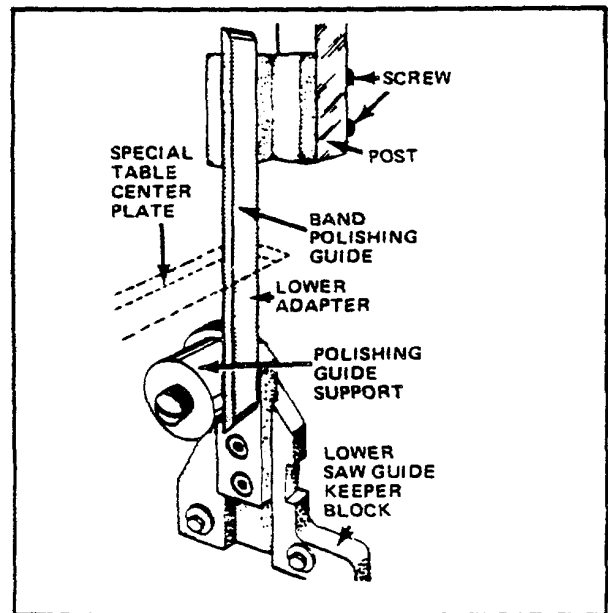

FIG. 49. BAND POLISHING GUIDES.

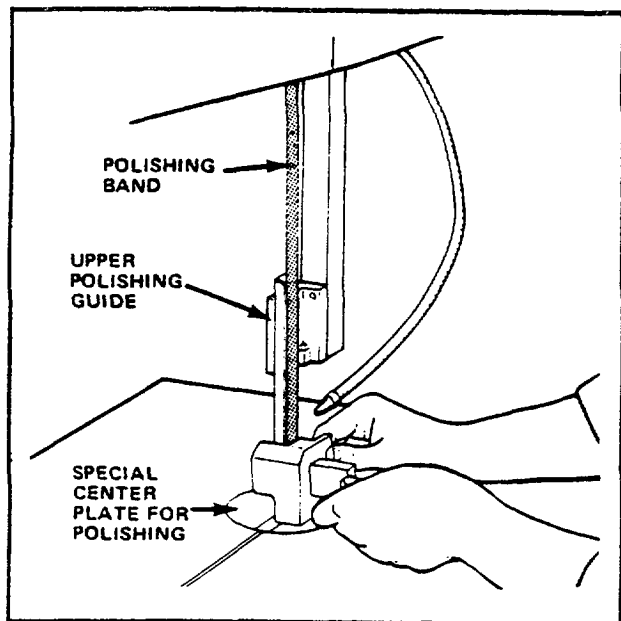

FIG. 50. BAND POLISHING OPERATION.

Occasionally rub graphite powder into guide fabric to lubricate and increase band life. Do not use coolant with polishing bands. Use air nozzle to blow dust away.

Three polishing band grain sizes are available in aluminum oxide or silicon carbide. See Fig. 51. Use No. 50 (coarse) for heavy stock removal and soft materials, No. 80 (medium) for general surface finishing, and No. 150 (fine) for high polish and light stock removal.

<u>Application</u>	<u>Cutting Speeds</u>	<u>Grit</u>
Grinding	50-300 fpm (15-90 m/min)	50
Polishing- coarse	850-1000 fpm (260-305 m/min)	80
Polishing- fine	850-1500 fpm (260-450 m/min)	150

FIG. 51. POLISHING APPLICATION, SPEED AND GRAIN RECOMMENDATIONS.

INDEX NO. A-2

FICHE NO. A-47 CLASS _____ CONTOUR _____ MODEL 3613-20 SERIAL NO. 399-78101 TO Present

PAGE NO,	DESCRIPTION	FIRST SERIAL	LAST SERIAL	DWG.	P. LIST	FICHE NO.
C-1-60	Final Assembly	ALL		A-3	A-4	
C-8-57	Air Compressor	ALL		A-5	A-6	
C-8-54	Air Puma	ALL		A-7	A-8	
C-7-26	Band Filer	ALL		A-9	A-10	
C-7-26	Band Filer	ALL		A-9	A-10	
H1-19.0	Blade Shear	See Butt welder		F-9	F-10	H-2
C-10-39	Coolant	ALL		A-11	A-12	
C-8-63	Coolant, Mist, With Air Compressor	ALL		A-13	A-14	
C-10-28	Cutoff Attach. 12 Side Mount	ALL		B-1	8-2	
C-10-2	Disc Cutter	ALL		B-3	B-4	
C-5-72	Drive	ALL		B-5	B-6	
C-6-67	Electrical Assembly	ALL		B-7	B-8	
H1-20.0	Etching Pencil	See Butt welder		F-11	F-12	H-2
C-2-140	Extra Work Height	ALL		B-9	B-10	
C-2-141	Extra Work Height(Auxiliary Post Assembly)	ALL		B-1	B-12	
C-2-142	Extra Work Height(Post Elevating Sub-Ass'y)	ALL		B-13	B-14	
C-2-72	Head	ALL		C-3	C-4	
C-10-23	Heavy Work Slides	ALL		C-5	C-6	
C-8-104	Job Selector	ALL		C-7	C-8	
C-8-8	Lamp	ALL		C-9	C-10	
C-8-8	Magnifier (Lamp Mounted)	ALL		C-9	C-10	
C-10-38	Parallel Work Clamp	ALL		C-1	C-12	
C-2-65	Post Elevating Assembly	ALL		C-13	C-14	
CM-10-7	Protractor Work Stop	ALL		D-1	D-2	
C-10-6	Rip Fence	ALL		D-3	D-4	
C-10-39	Saw Eez Adapter	ALL		A-11	A-12	
C-7-18	Saw Guides, Insert Type	1 of 2	ALL	D-5	D-6	
C-7-20	Saw Guides, Insert Type	2 of 2	ALL	D-7	D-8	
C-7-19	Saw Guides, Roller Type		ALL	D-9	D-10	
C-10-29	Screw Feed	ALL		D-11	D-12	
C-3-41	Table & Trunnion	ALL		D-13	D-14	
C-3-78	Table, Air Feed	1 of 3	ALL	E-1	E-2	
C-3-79	Table, Air Feed	2 of 3	ALL	E-3	E-4	
C-3-80	Table, Air Feed	3 of 3	ALL	E-5	E-6	
C-3-38	Table, Secondary		ALL	E-7	E-7	
C-4-44	Transmission	ALL		E-9	E-10	
CM-10-9	Universal Cal. Work Fixture	ALL		E-11	E-12	
CM-10-1	Universal Vise	ALL		E-13	E-14	
C-9-16	Weight Feed Assembly	1 of 3	ALL	F-1	F-2	
C-9-17	Weight Feed Assembly	2 of 3	ALL	F-3	F-4	
C-9-18	Weight Feed Assembly	3 of 3	ALL	F-5	F-6	
C-2-28	Wheel, Third	ALL		F-7	F-8	
C-3-77	Work Holding Fixture	ALL		F-9	F-10	
C-10-16	Work Holding Jaws	ALL		F-11	F-12	

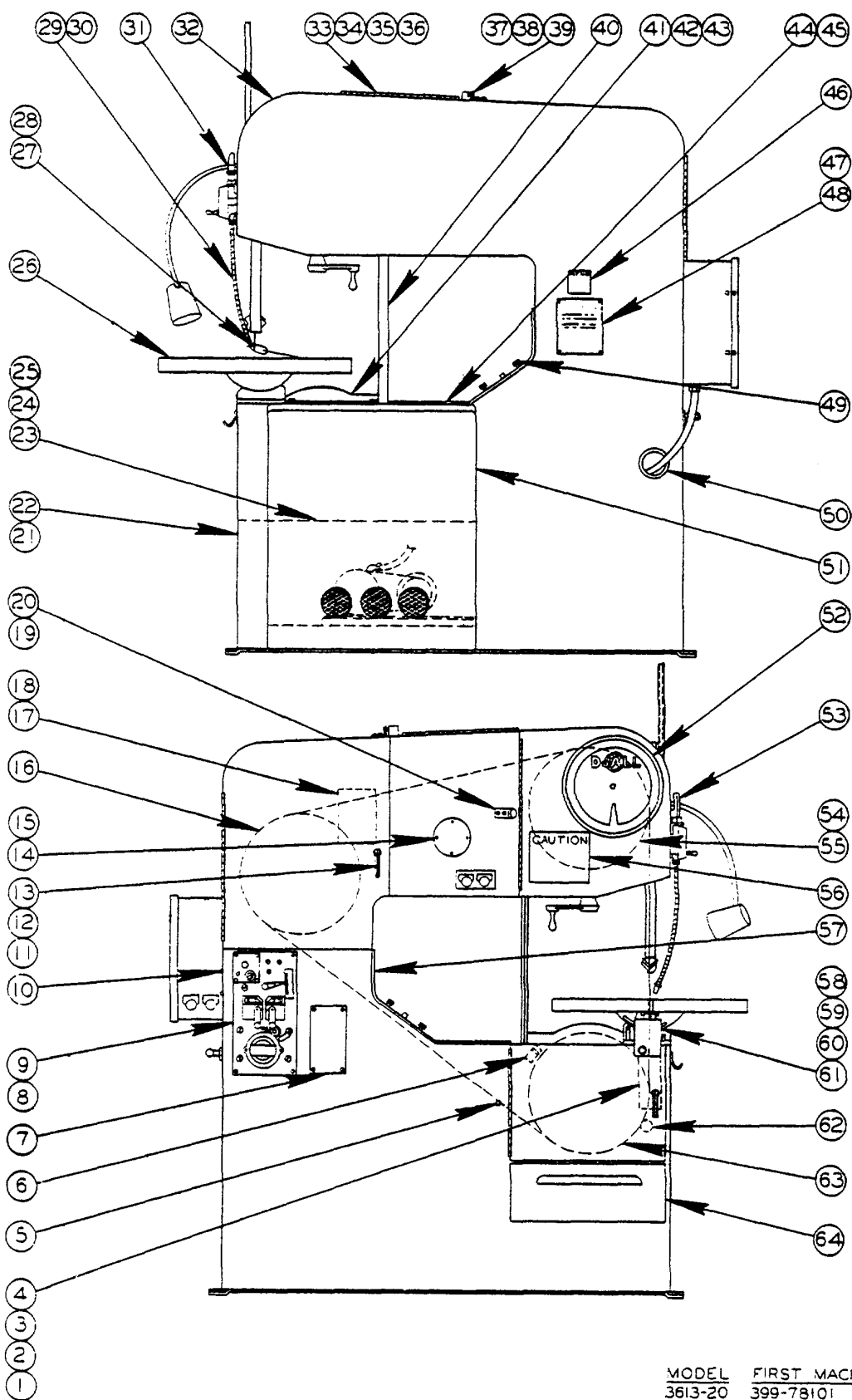

NEW ORG.
C.A.K. 3-8-78
REVISIONS

MODEL 3613-20 FIRST MACH 399-78101 LAST MACH

FINAL ASSEMBLY
C-1-60
28

FINAL ASSEMBLY

INDEX NO.	CATALOG NO.	DESCRIPTION	UNITS PER ASS'Y
Ref.	507170	Final Assembly	
1	091-238907	. Cover Plate	1
2	091-988972	. Screw, Rd. Hd. Mach. 1/4-20NC x 3/4	4
3	091-993212	. Washer, Lock 1/4	4
4	091-991158	. Nut, Hex. 1/4-20NC Full	4
5	090-122359	. Rubber Grommet	2
6	090-274077	. Wheel Brush Assembly	1
	090-166646	.. Brush Holder Weldment	1
	090-166844	.. Wheel Brush	1
	091-982207	.. Screw, Soc. Hd. Cap 410-24NC x 1/2	2
	091-992586	.. Washer, Flat #10 SAE	2
7	091-187039	. Cover	1
8	091-322727	. D8W-15 Butt Welder Assembly(See Welder Manual)	1
9	091-990200	. Screw, Truss Hd. Mach. 1/4-20NC x 1/2	12
10	090-074360	. Plug Button	2
11	090-168428	. Handle Assembly	2
12	105-021018	. Base Door Latch	2
13	091-984229	. Screw, Soc. Set 1/4-20NC x 1/4	2
14	135-014918	. Cover	1
15	091-988675	. Screw, Rd. Hd. Mach. #10-24NC x 3/8	6
16	090-413436	. Third Wheel & Hinge Assembly .(See Detail)	1
17	090-061805	. Cover Plate	1
18	091-988386	. Screw, Rd. Hd. Mach. #6-32NC x 1/4	4
19	090-060641	. Door Stop Bracket	1
20	091-993196	. Washer, Spring Lock #10 Med	2
21	090-033259	. Plug Button	1
22	090-135526	. Plug Sutton	4
23	091-056952	. Seal Strip	1
24	091-056960	. Clamp Strip	1
25	091-988568	. Screw, Rd. Hd. Mach. 48-32NC x 5/8	3
26	090-524356	. Table & Trunnion Assembly (See Derail)	1
27	091-408344	. Saw Band	1
28	093-045250	. Saw Bond Tog	1
29	090-040973	. Air Hose	1
30	105-045207	. 90° Street Elbow	1
31	094-061413	. Worklamp Assembly (See Detail)	1
32	506959	. Frame Assembly	1
33	090-382227	. Cover Assembly	1
34	091-988691	. Screw, Rd. Hd. Mach. 10-24NC x 1/2	5
35	090-010190	. Washer, 10 Wrought	1
36	091-991117	. Nut, Hex. 010-24NC	5
37	091-201412	. Bracket Assembly	1
38	091-971150	. Gray Felt	A.R.
39	134-015031	. Wheel Tire Cement	A.R.
40	094-063963	. Saw Band Guard Assembly	1
41	090-410762	. Lower Wheel Cover	1
42	091-980052	. Screw, Hex. Hd. Cap 1/4-20NC x 3/8	2
43	091-993212	. Washer, Lack 1/4	4
44	090-062910	. Plug Button	4
45	091-086017	. Plug Button	1
46	091-292730	. Escutcheon (Patent No.)	1
47	093-065910	. Escutcheon (Mach. Specs.)	1
48	091-993972	. Drive Screw 2 x 1/4	8
49	111-024014	. Thumb Screw	2
50	091-972364	. Grommet Strip	A.R.
51	095-071718	. Back Cover Sub-Assembly	1
52	090-468174	. Job Selector Assembly (See Detail)	1
53	090-234147	. Upper Door Latch Assembly	1
54	500372	. Head Assembly (See Detail)	1
55	090-070384	. Escutcheon (Bond Tension)	1
56	094-044765	. Escutcheon (Caution)	1
37	090-375015	. Cover Plate Assembly	1
58	090-411018	. Chip Baffle	1
59	091-980060	. Screw, Hex. Hd. Cop 1/4-20NC x 1/2	1
60	105-024012	. Thumb Screw	1
61	091-993212	. Washer, Lock 1/4	1
62	135-045250	. Plug Button	1
63	507173	. Drive Assembly (See Detail)	1
64	090-447988	. Chip Drawer Assembly	1
Following Items Not Shown:			
	094-068715	. Instruction Tag	1
	091-057018	. Seal Strip	1
	090-185000	. Upper Sow Guide Holding Screw	2

CODE NO. C-8-57
CM-8-32
Z-7-8

AIR COMPRESSOR

INDEX NO.	CATALOG NO.	DESCRIPTION	QUINCY CO. PART NO.	UNITS PER ASS'Y
Ref.	094-008950	Air Compressor (Quincy)		
1	091-186395	. Breather Assembly	2151-X	1
2	091-186403	. Replacement Felt	2149	1
3	091-186015	. Cylinder	2101	1
4	091-186023	. Stud Breather	7178	1
5	091-186031	. Breather Valve Bumper	2118	2
6	091-186049	. Breather Valve	2117	1
7	091-186056	. Bearing Cup	6553	1
8	091-186064	. Bearing Cone	6554	1
9	091-186411	. 6" Pulley For X-2 Compressor		Use
	091-186429	. 8" Pulley For X-2 Compressor		One
10	091-186072	. Bearing Carrier	6972	1
11	091-186080	. Bearing Plate Gasket	2115	2
12	091-186098	. Connecting Rod Assembly	2105	1
13	091-186106	. Connecting Rod Bolt Wire	2830	1
14	091-186114	. Oil Pan	2122	1
15	091-186122	. Oil Pan Gasket	2123	1
16	091-186130	. Oil Drain Plug	2140	1
17	091-186148	. Connecting Rod Bolt	2120	1
18	091-186155	. Connecting Rod Bolt lockwasher	2121	1
19	091-186163	. Bearing Cup	6551	1
20	091-186171	. Bearing Cone	6552	1
21	091-186189	. Crank Shaft	6975	1
22	091-186197	. Bearing Carrier	6973	1
24	091-209437	. Piston Compressor Ring.....	6489	3
25	091-186262	. Suction Valve Spring	2132	1
26	091-186270	. Suction Valve Bumper	2131	1
27	091-186239	. Piston Pin Assembly	2126-X	1
28	091-186247	. Piston	2104	1
29	091-186254	. Head Gasket	2124	1
30	091-186288	. Suction Valve Bumper Gasket	2130	1
31	091-186304	. Cylinder Head	2100	1
32	091-T86312	. Suction Valve Seat.....	2129	1
33	091-186320	. Discharge Valve Bumper	2133	1
34	091-186338	. Intercooler Gasket	2134	1
35	091-186346	. Discharge Valve Spring	1780	1
36	091-186296	. Valve	1194	2
37	091-186361	. Discharge Valve Guide	2136	1
38	091-186379	. Discharge Valve Guide.....	2137	1
39	091-186387	. Oil Gauge Assembly .	2316-X	1
40	094-008356	. Air Compressor (6" Pulley)		Use
	094-019577	. Air Compressor (8" Pulley)		One
41	090-372525	. Adapter Plate Weldment		1
42	091-980276	. Screw, Hex. Hd. Cap 5/16-18NC x 3/4 .		4
43	091-992628	. Washer, Flat 5/16 Std		4
44	091-991224	. Nut, Hex. 5/16-18NC.....		4
45	091-993238	. Washer, Lock 5/16 Std		4
46	090-021031	. Relief Valve		1
47	135-008472	. Service Tee		1
48	090-020041	. Barbed Insert		1

REVISED AND REDRAWN 1-25-68
D.E. 7-29-68
S.W. 4-24-72
S.G.L. 11-14-74

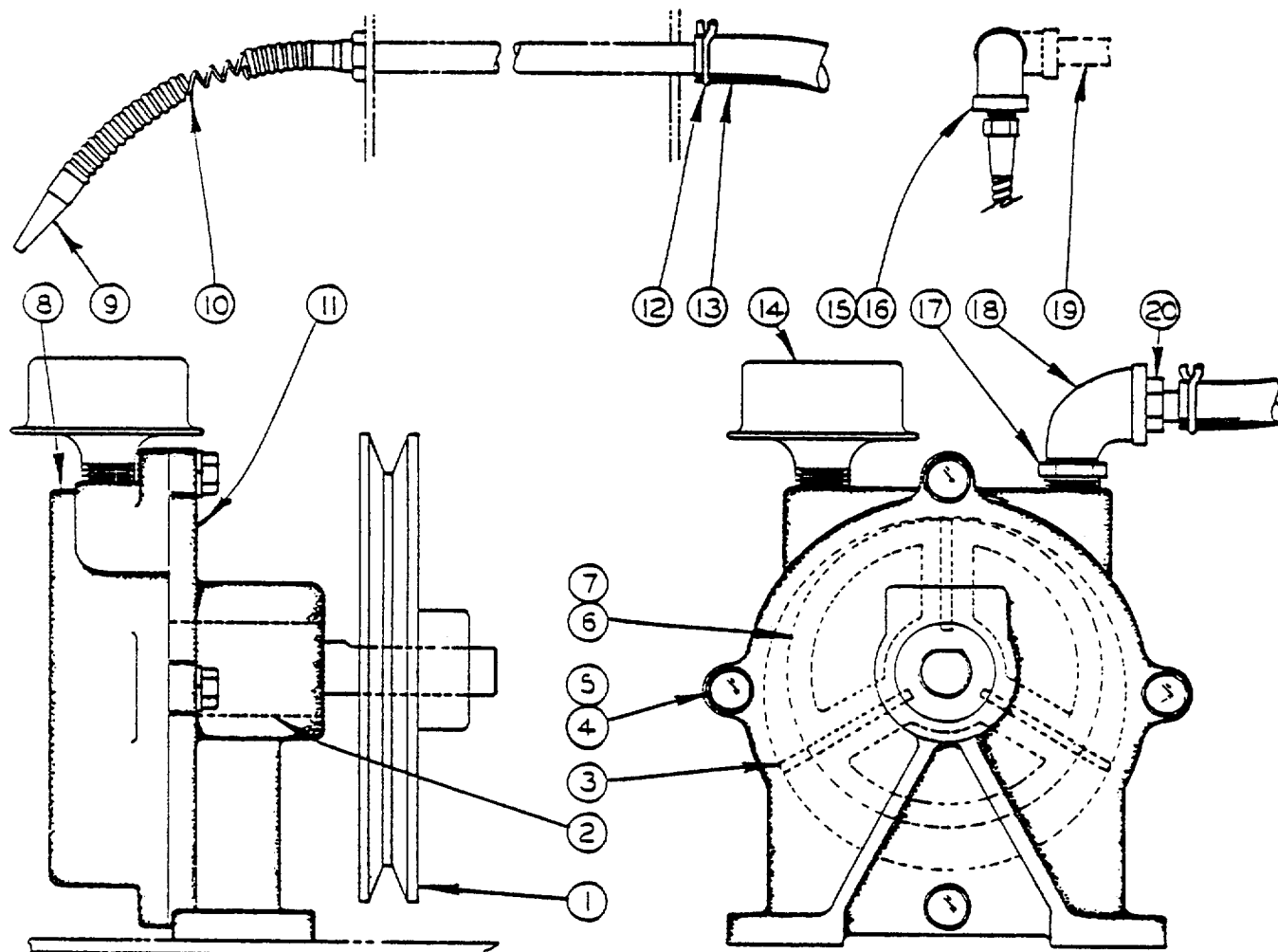

AIR PUMP ASSEMBLY

C-8-54 CM-8-35

CODE NO. C-8-54
CM-8-35

AIR PUMP ASSEMBLY

INDEX NO.	CATALOG NO.	DESCRIPTION	UNITS PER ASS'Y
Ref.	094-071594	Air Pump Assembly (Clockwise Rotation)	
Ref.	090-427089	Air Pump Assembly (Counter-Clockwise Rotation)	
* 1	105-113161	. Pulley	1
2	105-114052	. Bearing	1
3	105-113195	. Vane	3
4	091-980086	. Screw, Hex. Hd. Cap 1/4-20NC x 3/4	4
5	091-993741	. Washer, Lock 1/4" I.D. Shakeproof Ext	4
6	105-111041	. Air Pump Rotor	1
7	091-984252	. Screw, Soc. Set 1/4-20NC x 1/2"	2
8	135-067361	. Air Pump Body	1
* 9	090-060732	. Air Hose (1612-1)	1
	090-040973	. Air Hose (1612-U, 3012-U, 3613-1, 1612-0)	1
*10	090-046582	. Wire Insert	1
11	135-067253	. Air Puma Cover	1
*12	090-179029	. Hose Clamp	2
*13	090-000084	. Hose	A.R.
14	105-115109	. Air Cleaner	1
*15	135-036473	. 90° Elbow (1612-U & 3012-U)	2
*16	114-145287	. Close Nipple (1612-U & 3012-U)	1
17	105-115174	. Reducer	1
18	117-135210	. Street Elbow 1/4" Std.	1
*19	090-083866	. Nipple (1612-U & 3012-U)	1
20	090-020041	. Barbed Insert	1

***NOTE: Single Starred Items Are Not Part Of Air Pump Assembly.**

REVISED AND REDRAWN
SCL. 1-2-79

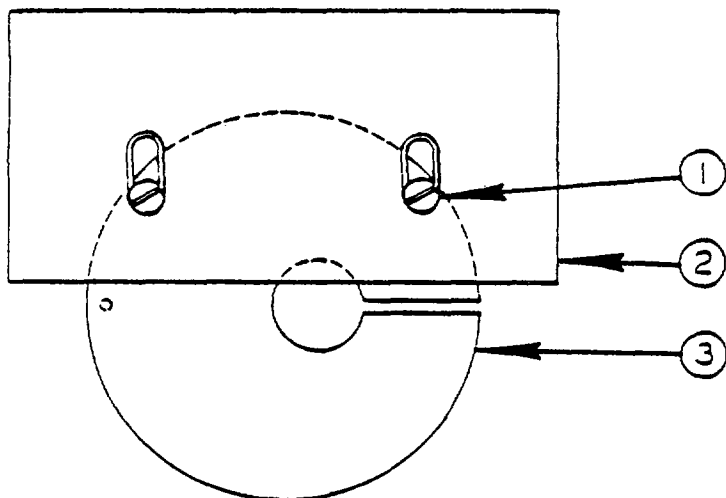

SMALL PARTS FILING ASSEMBLY

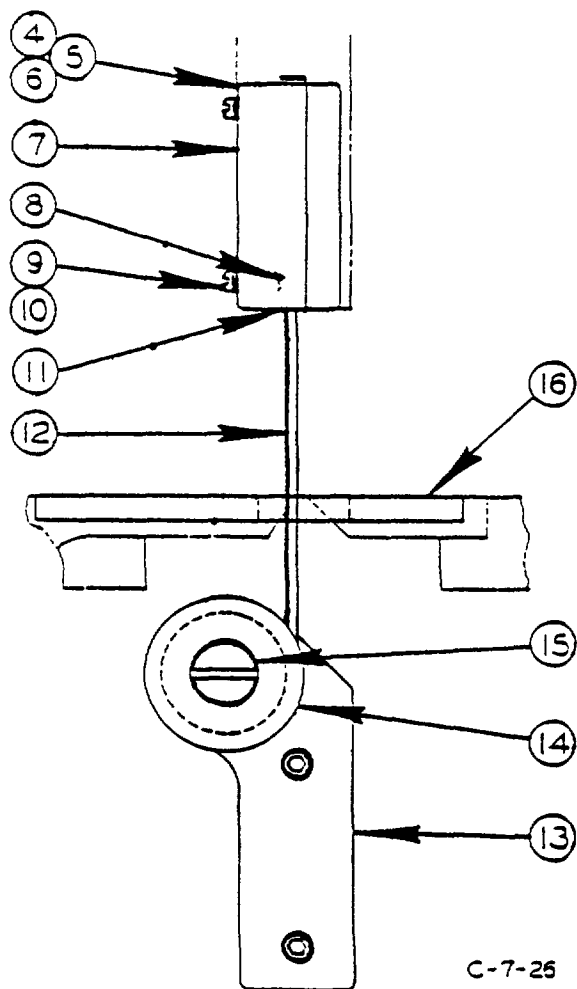

C-7-25 CM-7-25

BAND FILING ASSEMBLY

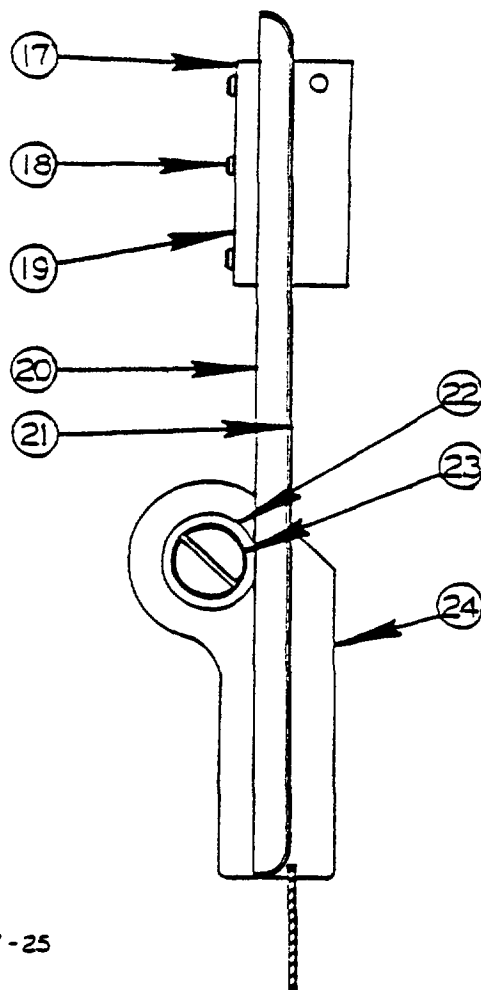

BAND POLISHING ASSEMBLY

BAND FILING & POLISHING ASSEMBLIES

INDEX NO.	CATALOG NO.	DESCRIPTION	UNITS PER ASS'Y	INDEX NO.	CATALOG NO.	DESCRIPTION	UNITS PER ASS'Y
Ref. 1	090-076456	Small Parts Filing Ass'y .1612, 1612-0, 612-H, 1612-1, 2013, 2013-1, 2013-0, 2013-10, 2012-1A, 2012-A, 2012-AT, 2012-IAT, 2612-H, 2612-1, 3612, 3613-0 3612-H, 3613-1)		9	091-986885	.. Screw, Fil. Hd. Mach. #4-40NC x 5/8 (Ass'ys #27487, #27490, #34096, #34099)	2
1	091-98747	. Screw, Fil. Hd. Mach. #10-24NC 3/8	2		091-986992	.. Screw, Fil. Hd. Mach. #10-24 NC x 5/8 (Ass'y #37488, #27491, #34097, #34103, #27489, #27492, #34098, #34104)	2
2	090-120460	. Small Part late	1	10	091-993154	.. Washer, Lock #4 Std. (Ass'ys #27490, #34099)	2
3	090-120452	. Canter Plat	1		091-993196	.. Washer, Lock #10 Std. (Ass'ys #27488, #27491, #34097, #34103, #27489, #27492, #34098, #34104)	2
Ref.	090-147806	Band Filing Ass'y 1612, 1612-0, 1612-H, 1612-1, 1613-2, 1612-3, 2013, 2013-1, 2013-0, 2013-10 2012-A, 2012-1A, 2012-AT, 2012-IAT, 2612-2H, 2613-3, 3612-H, 3613-4, 3612-3, 6013-3)		11	106-093073	.. Insert (Ass'ys #27487, #34096).	1
Ref.	091-119A87	Band Filing Ass'y 1612, 1612-0, 1612-H, 1612-1, 1612-3, 2013, 2013-1, 2013-0, 2013-10, 2012-A, 2012-IA, 2012-AT, 2012-1AT, 3612-H, 3612-3)		11	106-093032	.. Insert (Ass'ys #27490, #34099).	1
Ref.	091-327734	Band Filing Ass'y (1612, 1612-0, 2013, 2013-4, 2013-0, 2013-40, 2012-A, 2012-AT, 2612-H, 2612-1, 3612, 3613-0)		11	106-093016	.. Insert (Ass'ys #27488, #34097).	1
Ref.	094-049947	Band Filing Ass'y (1612, 1612-0, 2013, 2013-1, 2013-0, 2013-10, 2012-A, 2012-AT, 2612-2H, 2612-1, 3612, 3613-0)		11	106-093057	.. Insert (Ass'ys #27491, #34103) ..	1
Ref.	390-a85327	Band Filing Ass'y (1612-3, 2612-2H, 2612-3, 3612-3, 6013-3)		11	106-093099	.. Insert (Ass'ys #27489, #34098) ..	1
Re.	094-014388	Band Filing Ass'y (1613-3, 2612-2H, 2613-3, 3612-3, 6013-3)		11	106-093115	.. Insert (Ass'ys #27492, #34104) ..	1
Ref.	090-447814	Band Filing Ass'y (2613-2, 3612-2, 6013-3)		12	106-093081	.. File Guide (Ass'ys #27487, #34096)	1
Ref.	090-455973	Band Filing Ass'y (3613-2, 6013-2)		12	106-093040	.. File Guide (Ass'ys #27490, #34099)	1
4	090-274879	. 1/4" File Guide Ass'y (Ass'ys #44780, #40994, 44781)	1		106-093024	.. File Guide (Ass'ys #27488, #34097)	1
	090-274903	. 1/4A File Guide Ass'y (Ass'ys #111948, #132773, #45597)	1		106-092065	.. File Guide (Ass'ys #27491, #34103)	1
	090-340969	. 1/4" File Guide Ass'y (Ass'y #48532)	1		106-093107	.. File Guide (Ass'ys #27489, #34098)	1
	090-340993	. 1/4" File Guide Ass'y Ass'ys #40438)	1		106-093123	.. File Guide (Ass'ys #27492, #34104)	1
5	3903-274887	. 3/8" File Guide Ass'y (Ass'ys #44780, #404994, #43781)	1		134-093137	.. Guide Plates (Not Shown Ass'ys #27490, #34099)	2
	090-274911	. 3/8" File Guide Ass'y (Ass'y, #111948, #132773, #45597)	1		134-09A28	.. Pin (Not Shown) Ass'ys #27490, #34099)	2
	090-340977	. 3/8" File Guide Ass'y (Ass'y #48532)	1	13	090-013715	. Adapter	1
	090-341033	. 3/8" File Guide Ass'y (Ass'y 401438)	1	14	134-093129	. File Guide Back-up (Ass'ys #44780, #111948, #132772, #404994, #44781, #45597)	1
6	090-274895	. 1/2" File Guide Ass'y 'Ass'ys #44780, #404994, #44781)	1		091-109314	. File Guide Back-up (Ass'ys #48532, #401438)	1
	090-274929	. 1/2" File Guide Ass'y (Ass'ys. #111948, #132773, #45597)	1	15	134-090018	.. Screw Assembly	1
	090-340985	. 1/2" File Guide Ass'y (Ass'ys. #48532)	1		090-038019	.. Head	1
	090-341041	. 1/2" File Guide Ass'y (Ass'y #401438)	1		090-038027	.. Screw	1
7	090-274176	.. Bracket (Ass'y #27487)	1	16	090-106279	. Center Plate (Ass'ys #44780, #111948 #48532, #401438)	1
	090-274184	.. Bracket (Ass'y #27490)	1		091-201285	. Center Plate (Ass'ys #132773, #404994)	1
	090-340951	.. Bracket (Ass'y #34096)	1	Ref.	091-069575	Band Polishing Ass'y (1611-H, 1611-U 1612, 1612-0, 1612-H, 1612-1, 2013, 2013-1, 2013-0, 2013-10, 2012-A, 2012-1A, 2012-AT, 2012-1AT, 2612-H 2612-1, 3612-U, 3612, 3613-0, 3612-H 3613-1)	
	090-340944	.. Bracket (Ass'y #34099)	1	Ref.	090-290230	Band Polishing Ass'y (1612-1, 1613-2, 1612-3, 3613-1, 3613-2, 3612-3)	
	090-274200	.. Bracket Ass'y #27488	1	Ref.	090-274853	Band Polishing Ass'y (26-2, 60-2, 2612-2H, 2613-2, 6013-2)	
	090-27A218	.. Bracket Ass'y #27491	1	Ref.	090-274846	Band Polishing Ass'y (16-2, 16-3, 36-2, 36-3)	
	090-340936	.. Bracket Ass'y #34097	1	Ref.	090-274861	Band Polishing Ass'y (26-3, 60-3, 2613-3, 6013-3)	
	090-340928	.. Bracket Ass'y #34103	1	Ref.	091-069583	. Band Polishing Ass'y (2612-1)	
	090-274192	.. Bracket Ass'y #27489	1	17	090-166869	. Band Polishing Sub-Ass'y (Ass'ys #106957, #29023, #27485, #27484, #106958)	
	090-274226	.. Bracket Ass'y #27492	1		090-274143	. Band Polishing Sub-Ass'y Ass'y #27486)	1
	090-340910	.. Bracket Ass'y #34098	1	18	091-986968	.. Screw, Fil. Hd. Mach. #10-24 NC x 3/8	3
	090-340902	.. Bracket (Ass'y #34104	1	19	090-274127	.. Bracket	1
8	106-093149	.. Washer Ass'ys #27487, #27490, #34096, #34099)	2	20	106-103013	.. Backup Plate (Ass'y #16686)	1
	106-093131	.. Washer Ass'ys #27488, #27491, #34097, #34103, #27489, #27492 #34098, #34104)	2	21	135-099232	.. Backup Plate (Ass'y #27414)	1
				22	134-105055	.. Backup Cloth	1
				23	134-104025	. Guide Backup	1
					134-090018	. Screw Assembly	1
					090-038019	.. Head	1
					090-038027	.. Screw	1
				24	090-013715	. Adapter	1
					090-105701	. Center Plate (Not Shown) (Ass'ys #106957, #106958)	1

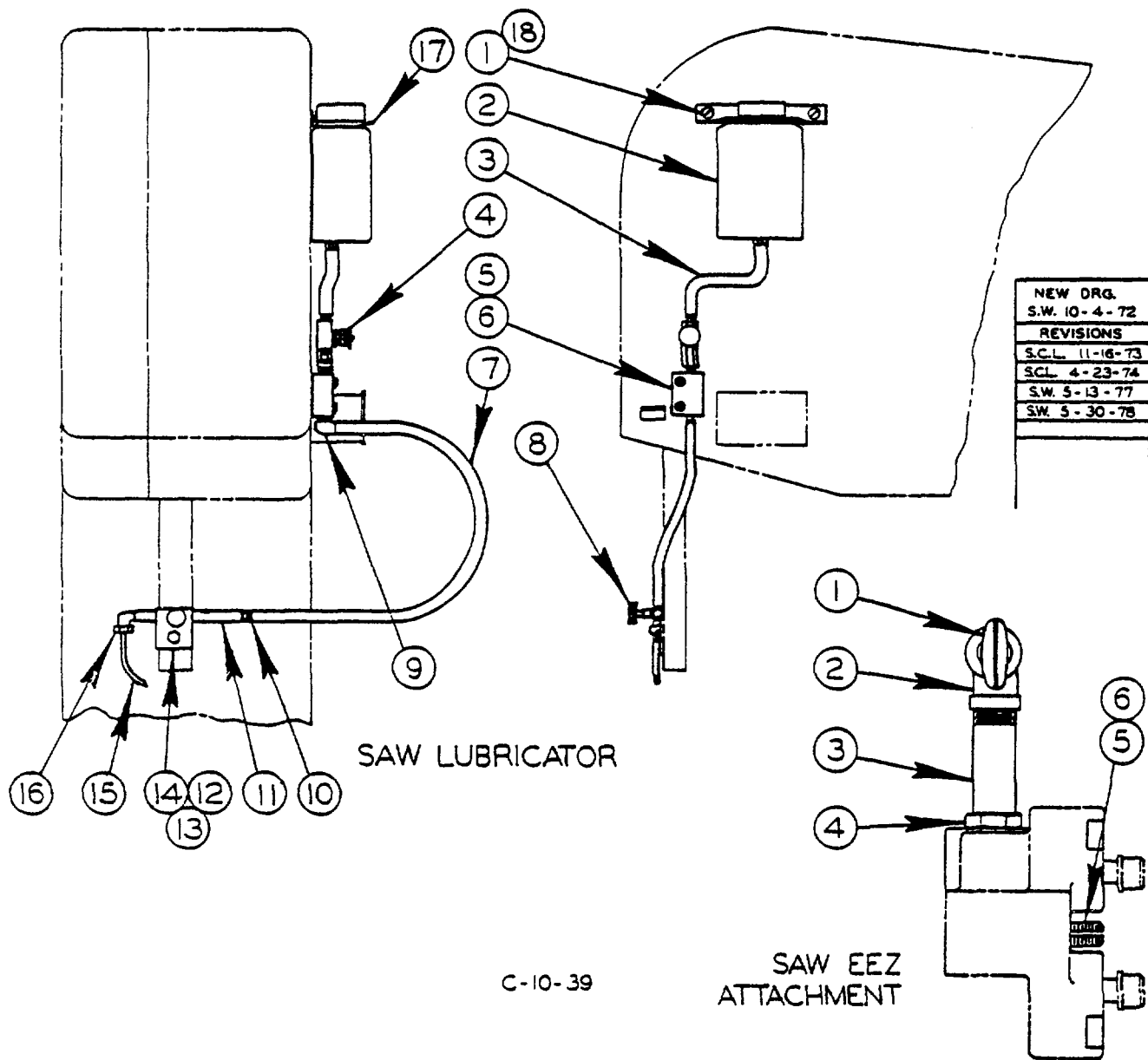

C-10-39

SAW LUBRICATOR ATTACHMENTS

CODE NO. C-10-39

SAW LUBRICATOR ATTACHMENTS

INDEX NO.	CATALOG NO.	DESCRIPTION	UNITS PER ASS'Y
Ref.	095-028122	Saw Lubricator (2612-1)	
Ref.	135-073286	Saw Lubricator (All Other Models Listed)	
1	091-988931	. Screw, Rd. Hd. Mach. 1/4-20NC x 3/8.....	2
* 2	091-369181	. Bottle Assembly	1
3	091-971440	. Plastic Tubing 1/4"	A.R.
4	105-275077	. Sight Feed Valve	1
5	090-120643	. Manifold	1
6	091-988782	. Screw, Rd. Hd. Mach. #10-24NC x 11/2	2
7	091-971440	. Plastic Tubing 1/4"	A.R.
8	134-174010	. Thumb Screw	1
9	091-081166	. 90° Barbed Insert	1
10	090-160011	. Barbed Insert	2
11	091-213108	. Adjustable Slide Rod.....	1
12	105-271027	. Post Lubricator Holder	1
13	091-980268	. Screw, Hex. Hd. Mach. 5/16-18 NC 5/8.....	1
14	091-993238	. Washer, Lock 5/16" Std.....	1
15	105-273015	. Tube	1
16	091-140632	. 90° Male Elbow.....	1
17	093-039568	. Bracket	1
18	091-993212	. Washer, Lock 1/4" Med	2
Ref.	090-310442	Saw Eez Attachment	
1	135-081495	. Saw Eez	1
2	135-036473	. Elbow	1
3	135-013514	. Nipple	1
4	107-015104	. Pipe Nut	1
5	135-004554	. Saw Lub. Pin (Bands 5/8" To. 1")	Use
6	135-004513	. Saw Lub. Pin (Bands 1/16 To 1/2")	One

***NOTE: To Replace Other Preceding Style Coolant Tanks, Metal or Plastic, Order 090-851577 Coolant Tank Service Kit.**

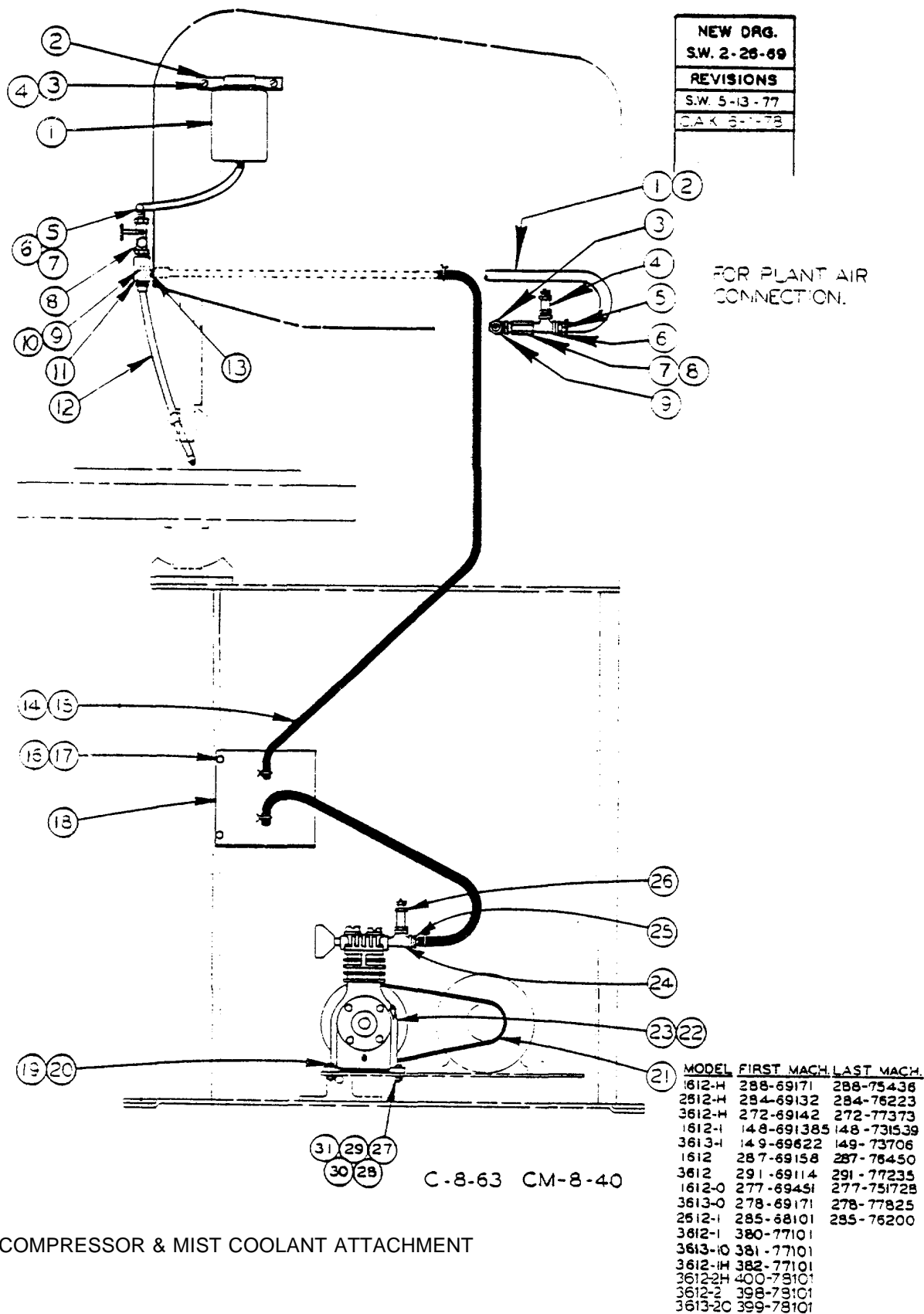

AIR COMPRESSOR & MIST COOLANT ATTACHMENT

AIR COMPRESSOR & MIST COOLANT ATTACHMENT

INDEX NO.	CATALOG NO.	DESCRIPTION	UNITS PER ASS'Y
Ref.	500190	Air Compressor & Mist Coolant Attachment(2612-H) (50 Hz)	
Ref.	500183	Air Compressor & Mist Coolant Attachment(1612-H, 3612-H, 1612,3612,1612-0,36130, 3612-2H,3612-2,3613-20)	
Ref.	500666	Air Compressor & Mist Coolant Attachment(2612-1,2612-H)	
Ref.	504166	Air Compressor & Mist Coolant Attachment(3612,3612-H) (50 Cycle)	
* 1	091-369181	. Bottle Assembly	1
2	093-039568	. Bracket	1
3	091-988931	. Screw, Rd. Hd. Mach. 1/4-20NC x 3/8	2
4	091-993212	. Washer, Lock 1/4" Med	2
5	090-385121	. Coolant Manifold Assembly (500190)	Use
	090-381245	. Coolant Manifold Assembly (500183,500666,504166)	One
6	091-971440	.. Plastic Tubing 1/4	A.R.
7	091-081166	.. 90° Barbed Insert.....	1
8	105-275077	.. Sight Feed Valve	1
9	091-199778	.. Coolant Tube Sub-Assembly (Ass'y #090-381245)	Use
10	091-199117	.. Coolant Tube Sub-Assembly (Ass'y #090-385121)	One
11	091-199109	.. Manifold	1
12	090-040973	.. Air Hose (Ass'y #-# 090-381245).....	Use
	090-060732	.. Air Hose (Ass'y #090-385121)	One
13	114-145287	. Close Nipple	1
14	091-970947	. Black Neoprene Hose 3/8" I. D.....	A.R.
15	090-179029	. Hose Clamp	2
16	091-980250	. Screw, Hex. Hd. Cap 5/16-18NC x 1/2	2
17	091-993238	. Washer, Lock 5/16" Std	A.R.
18	090-374901	. Air Dome Sub-Assembly (500190)	Use
	090-389347	. Air Dome Sub-Assembly(500183, 500666,504166).....	One
** 19	091-980276	. Screw, Hex. Hd. Cop 5/16-18NC x 3/4	A.R.
** 20	091-991224	. Nut, Hex. 5/16-18NC.....	A.R.
21	135-024164	. V-Belt (500666)	Use
	135-003408	. V-Belt (500666)	
	090-039546	. V-Belt (504166)	One
22	090-389339	. Air Compressor Sub-Assembly(Ref. For 500666)	1
23	094-019577	. Air Compressor	1
24	135-008472	. Service Tee	1
25	090-020041	. Barbed Insert	1
26	091-180885	. Safety Valve	1
	091-384461	. Oil (Not Shown)	A.R.
** 27	091-980342	. Screw, Hex. Hd. Cap 5/16-18NC x 2 1/2	2
** 28	091-980276	. Screw, Hex. Hd. Cop 5/16-18NC x 3/4	A.R.
** 29	091-992628	. Washer 5/16" Std	6
** 30	091-211607	. Spacer	2
** 31	091-211615	. Spacer	1
** 32	091-211631	. Plate Weldment (Not Shown)	1

* NOTE: To Replace Other Preceding Style Coolant Tanks, Metal or Plastic, Order #090-851577 Coolant Tank Service Kit.

**Double Starred Items are Used on Assemblies #500666 & 504166 Only.

Ref.	503546	Mist Coolant Attachment (Plant Air) (1612,3612,1612-0,3613-0,2612-1,3613-20)	
1	091-970947	. Black Neoprene Hose 3/8" I. D.....	A.R.
2	090-179029	. Hose Clamp	2
3	091-256735	. Bulkhead Adaptor	1
4	091-180885	. Safety Valve	1
5	090-020041	. Barbed Insert	1
6	135-008472	. Service Tee	2
7	093-034171	. Orifice	
8	114-145287	. Close Nipple	2
9	105-046122	. Pipe Plug	1
Following Items Not Shown:			
	091-369181	. Bottle Assembly	1
	090-381245	. Coolant Manifold Assembly	1
	093-039568	. Bracket	1
	091-988931	. Screw, Rd. Hd. Mach. 1/4-20NC x 3/8	2
	091-993212	. Washer, Lock 1/4.....	2

REVISED AND REDRAWN
SCJ 11-28-74
SW 5-13-77

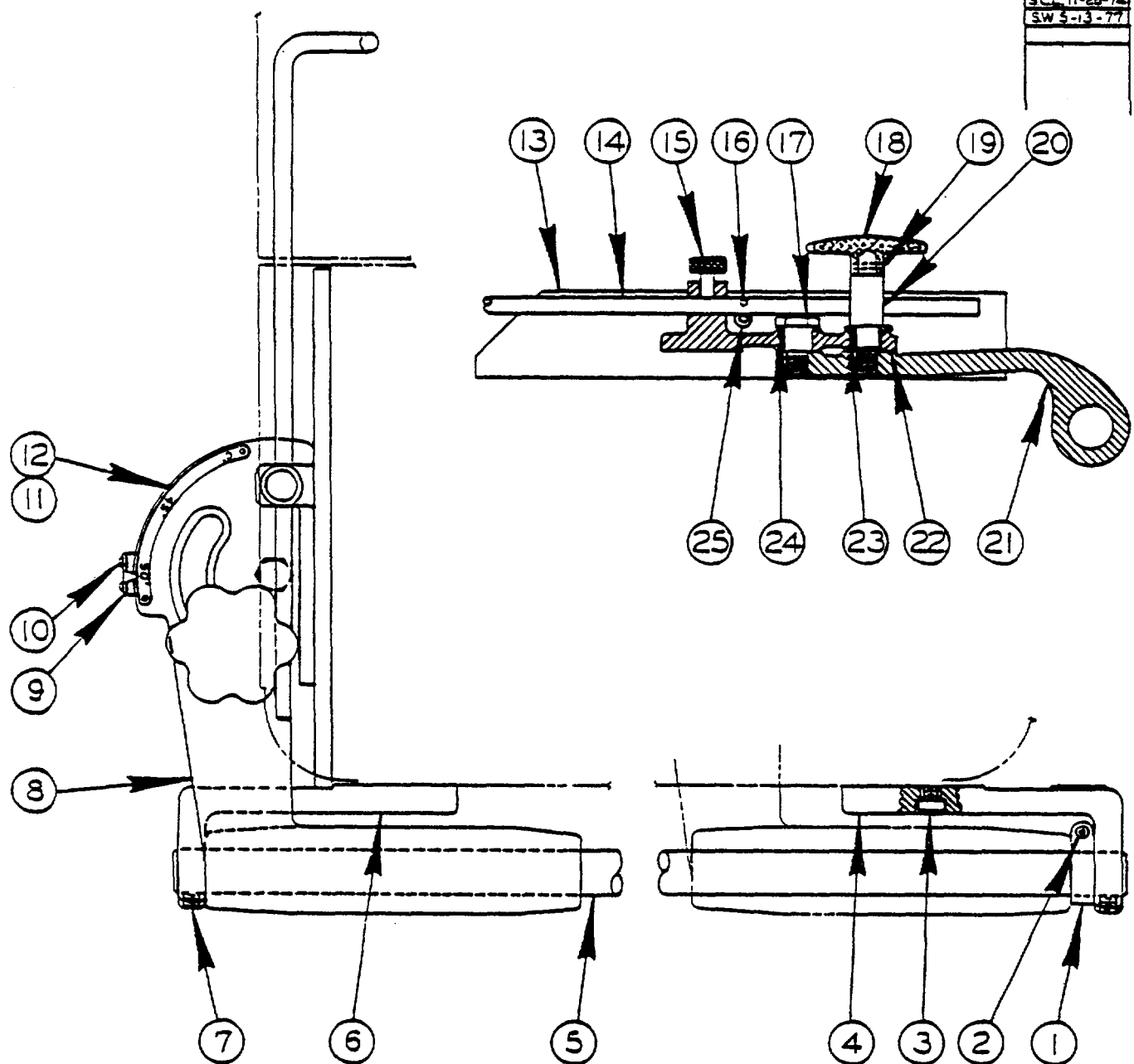

C-10-28 Z-10-5

NO. 2
STANDARD CUT-OFF & MITERING ATTACHMENT
(SIDE MOUNT)

CODE NO.	C-10-28
	Z-10-6

NO. 2 STD. CUT-OFF & MITERING ATTACHMENT

INDEX NO.	CATALOG NO.	DESCRIPTION	UNITS PER ASS'Y
Ref.	090-504192	No. 2 Std. Cut-off & Mitering Attachment (20" x 20" Table)	
Ref.	090-552902	No. 2 Std. Cut-off & Mitering Attachment (24" x 24" Table)	
Ref.	090-553058	No. 2 Std. Cut-off & Mitering Attachment (26" x 26" Table)	
Ref.	090-505116	No. 2 Std. Cut-off & Mitering Attachment (30" x 30" Table)	
1	111-281093	. Stop.....	1
2	091-982207	. Screw, Soc. Hd. Cap, No.10-24NC x 1/2" (20" & 24" Tables).....	1
	091-983783	. Screw, Soc. Hd. Cap No.10-24NC x 5/16" (25" Table).....	1
	091-984237	. Screw, Soc. Hd. Set, 1/4-20NC x 5/16" (30" Table).....	1
3	091-982769	. Screw, Soc. Hd. Cap, 3/8-16NC x 1/2"(20" & 30" Tables).....	4
	091-982785	. Screw, Soc. Hd. Cap, 3/8-16NC x 3/4" (24" & 26" Tables).....	4
4	090-036823	. Rear Slide Rod Bracket (20" Table).....	1
	090-295833	. Rear Slide Rod Bracket (24", 26", & 30" Tables).....	1
5	103-204061	. Slide Rod (20" Table).....	1
	104-204011	. Slide Rod (24"Table).....	1
	091-019356	. Slide Rod (28" Table).....	1
	091-019315	. Slide Rod (30" Table).....	1
6	090-036815	. Front Slide Rod Bracket (20" Table).....	1
	090-295841	. Front Slide Rod Bracket (24", 26", & 30" Table).....	1
7	091-984237	. Screw, Soc. Hd. Set 1/4-20NC x 5/16".....	2
8	090-507112	. Miter Attachment Sub-Assembly (20" Table).....	1
	090-507104	. Miter Attachment Sub-Assembly (24" Table).....	1
	090-553041	. Miter Attachment Sub-Assembly (26" Table).....	1
	090-507120	. Miter Attachment Sub-Assembly (30" Table).....	1
9	090-036765	.. Pointer.....	1
10	091-990085	.. Screw, Oven Hd. Mach. No.8-32NC x 1/4" (Cad. Pltd.).....	2
11	090-036724	.. Degree Plate.....	1
12	091-993998	.. Screw, Rd. Hd. Drive, Pk. No.4 x 1/4 Type "U".....	4
13	103-203063	.. Miter Bar (20" Table).....	1
	104-203013	.. Miter Bar (24" Table).....	1
	091-029447	.. Miter Bar (26" Table).....	1
	111-203014	.. Miter Bar (30" Table).....	1
14	104-203021	.. Gauge Rod.....	1
15	134-174010	.. Thumb Screw.....	1
16	090-042540	.. Roll Pin.....	2
17	134-204072	.. Miter Head Pivot.....	1
18	090-051319	.. Handwheel.....	1
19	090-042292	.. Roll Pin.....	1
20	090-036773	.. Stud.....	1
Z1	090-405986	.. Slide Arm.....	1
22	090-209412	.. Miter Head.....	1
23	134-204106	.. Locking Stud Washer.....	1
24	134204098	.. Pivot Washer.....	1
25	091-982363	.. Screw, Soc. Hd. Cap, 1/4-20NC x 1/2".....	2

NEW DRG.
S.W. 8-22-69
REVISIONS

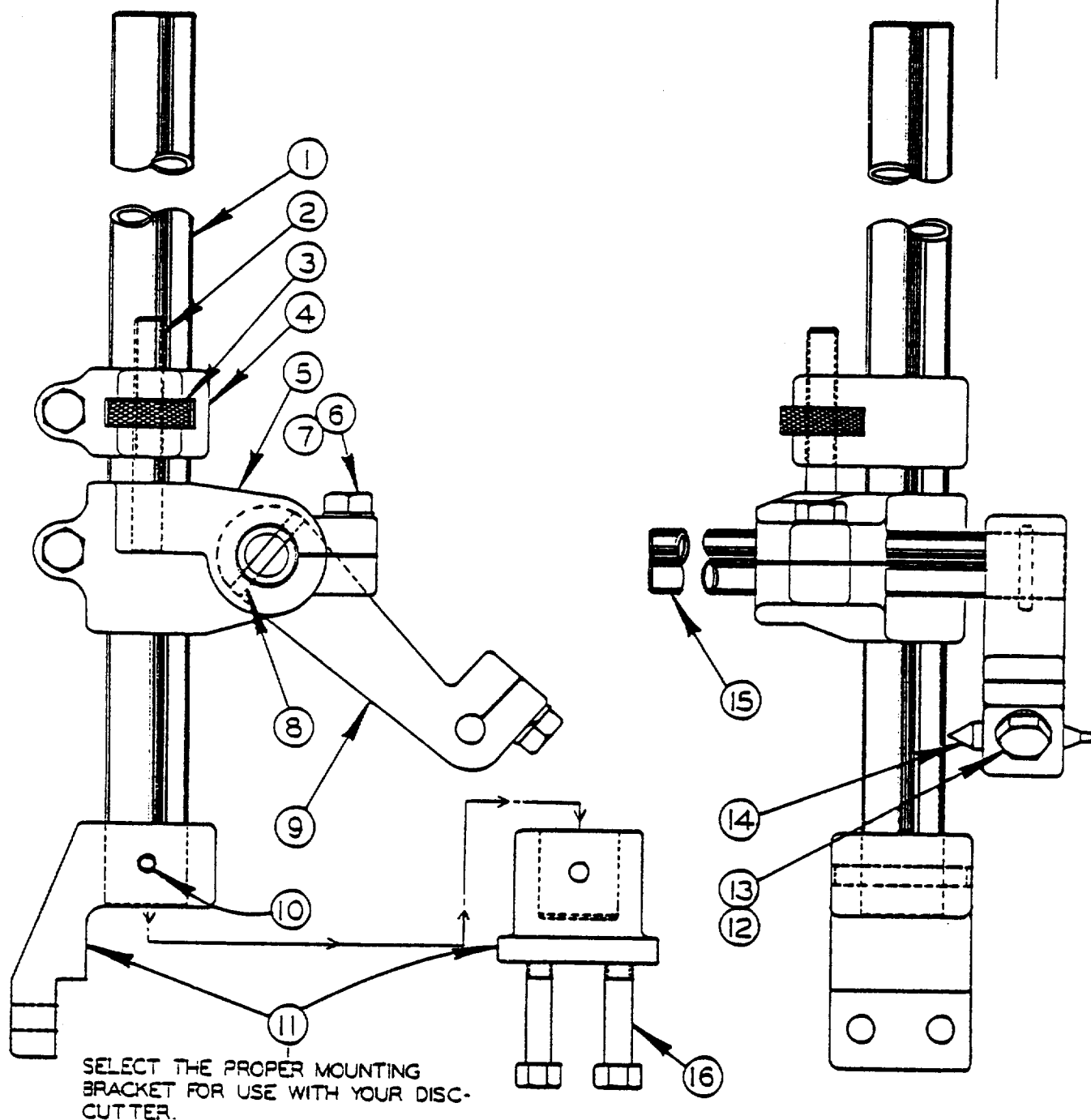

C-10-2 CM-9-1 Z-9-4

DISC CUTTER ASSEMBLY

CODE NO.	C-10-2
	CM-9-1
	Z-9-4

DISC CUTTER ASSEMBLY

INDEX NO.	CATALOG NO.	DESCRIPTION	UNITS PER ASS'Y
REF.	094-020807	Disc Cutter Assembly (Contour & Contour-Matic Machines)	
REF	090-400441	Disc Cutter Assembly (Zephyr, 6013-3, 6013-H3)	
1	135-033991	. Radius Arm	1
2	105-154132	. Adjustment Screw.....	1
3	105-154124	. Adjustment Wheel	1
4	105-151096	. Adjustment Housing	1
5	135-034007	. Radius Arm Clamp.....	1
6	091-980466	. Screw, Hex. Hd. Cap 3/8-16NC x 1.....	3
7	091-993329	. Washer, Lock 3/8 Std.....	3
8	090-042615	. Roll Pin	1
9	135-034023	. Center Pin Clamp.....	1
10	090-042763	. Roll Pin (Used on Ass'y #094-020807)	1
	090-042755	. Roll Pin (Used on Ass'y #090-400441)	1
11	090-390196	. Bracket (Used on Ass'y #094-020807)	1
	090-200452	. Bracket (Used on Ass'y #090-400441)	1
12	091-980292	. Screw, Hex. Hd. Cap 5/16-18NC x 1	3
13	091-993238	. Washer, Lock 5/16 Std	3
14	105-154157	. Center Pin	1
15	135-034015	. Center Adjustment Tube.....	1
16	091-980334	. Screw, Hex. Hd. Cap 5/16-18NC x 2(DZ-36 Only)	2
	091-980318	. Screw, Hex. Hd. Cap 5/16-18NC x 11/2 (All other Models)	2
	Following Items Not Shown:		
	134-203082	. Wrench	1
	091-980284	. Screw, Hex. Hd. Cop 5/16-18NC x 7/8 (Used Only on Ass'y k094-020807)	

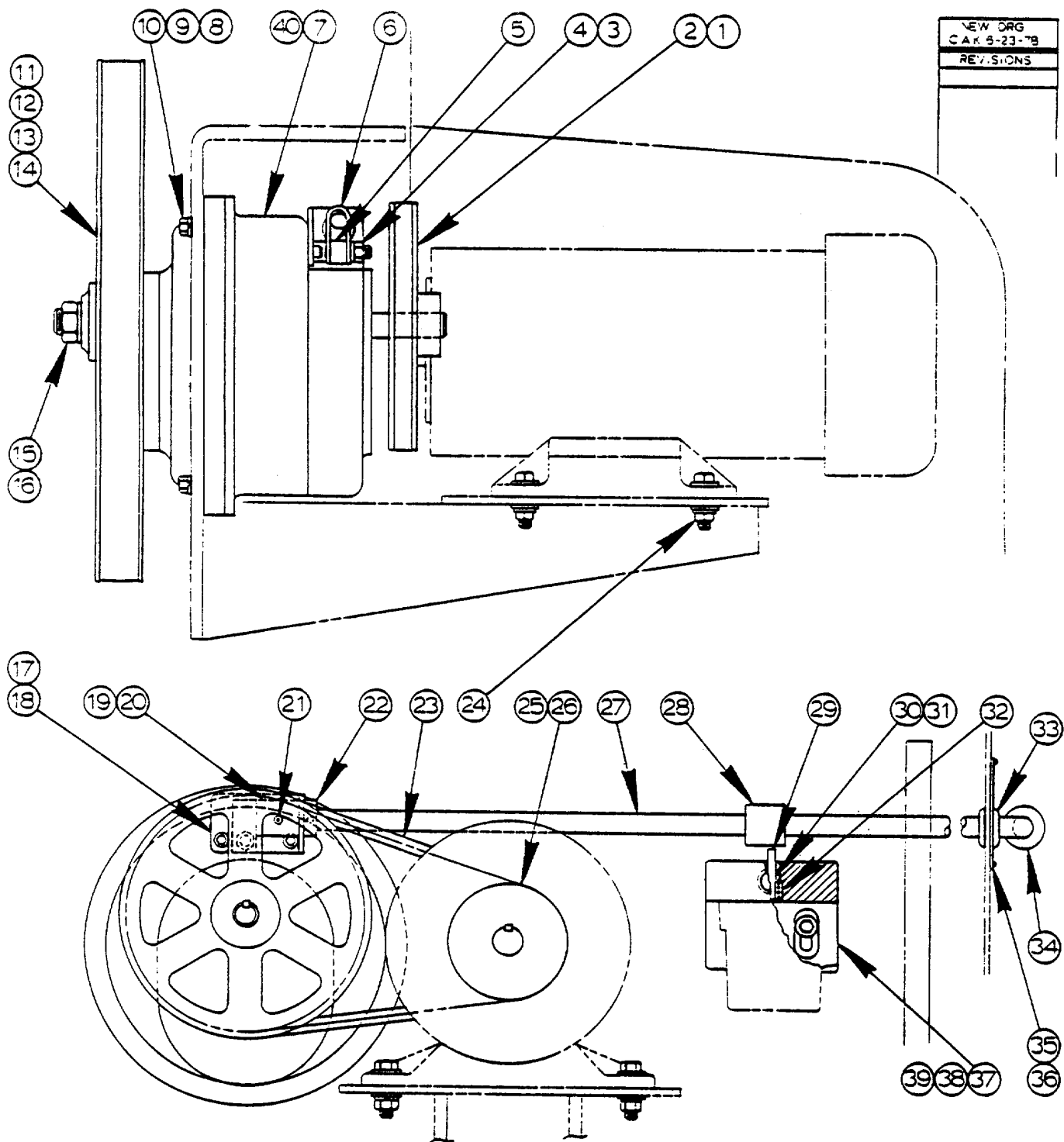

<u>MODEL</u>	<u>FIRST MACH</u>	<u>LAST MACH</u>
3612-2	398-78101	
3613-20	399-78101	
3612-2H	400-78101	
3612-2H3	401-78101	

C-5-72 CM-5-62
DRIVE ASSEMBLY

CODE NO.	C-5-72
	CM-5-62

DRIVE ASSEMBLY

INDEX NO.	CATALOG NO.	DESCRIPTION	UNITS PER ASS'Y
Ref.	507173	Drive Assembly (3612-2, 3613-20)	
Ref.	507343	Drive Assembly (3612-2H, 3612-2H3)	
1	091-444950	. Pulley	1
2	107-013450	. Key	1
3	091-983767	. Screw, Soc. Hd. Cap #6-32NC x 3/8	1
4	091-991265	. Nut, Hex. 3/8-16NC.....	1
5	135-065639	. Spacer	1
6	135-065621	. Shifter Segment	1
7	095-068276	. 2-Speed Transmission Assembly (See Detail)	1
8	091-980300	. Screw, Hex. Hd. Cop 5/16-18NC x 1 1/4"	8
9	091-993238	. Washer, Lock 5/16" Med.	10
10	135-066959	. Dowel Pin	1
11	091-333161	. Spacer 20 Ga.	A.R.
12	091-333179	. Spacer 22 Ga	A.R.
13	091-333187	. Spacer 10 Ga.	A.R.
14	090-294539	. Lower Saw Wheel Assembly(507173)	Use
	094-043395	.. Lower Wheel	1
	135-022705	.. Wheel Tire	1
	094-089737	. Wheel Assembly(507343)	One
15	091-991406	. Nut, Hex. Jam 3/4-10NC	1
16	091-993782	. Washer, Shakeproof Lock 3/4" External	1
17	090-040338	. Bracket	1
18	091-982363	. Screw, Soc. Hd. Cap 1/4-20NC x 1/2	2
19	106-044043	. Eccentric	1
20	091-984229	. Screw, Soc. Set 1/4-20NC x 1/4.....	2
21	090-042599	. Roll Pin	3
22	106-044159	. Shift Lever Collar	1
23	135-024164	. V-Belt.....	1
24	091-991224	. Nut, Hex. 5/16-18NC	4
25	091-450080	. Pulley.....	1
26	106-253057	. Key	1
27	091-136911	. Shift Lever	1
28	091-473066	. Shifter Lever Sleeve	1
29	091-473074	. Locking Pin.....	1
30	090-015124	. "O"-Ring	1
31	091-473090	. Bearing	2
32	091-473082	. Spring.....	1
33	090-075060	. Grommet.....	1
34	134-135086	. Shift Lever Knob	1
35	091-493395	. Escutcheon	1
36	091-993972	. Drive Screw #2 x 1/4.....	4
37	094-084100	. Bracket	1
38	091-980292	. Screw, Hex Hd. Cap 5/16-18NC x 1	2
39	091-992636	. Washer, Flat 5/16" SAE	1
40	090-096041	. Caulking Compound (507343 Only).....	A.R.

NEW DRG
CAK 8-23-78
REVISIONS

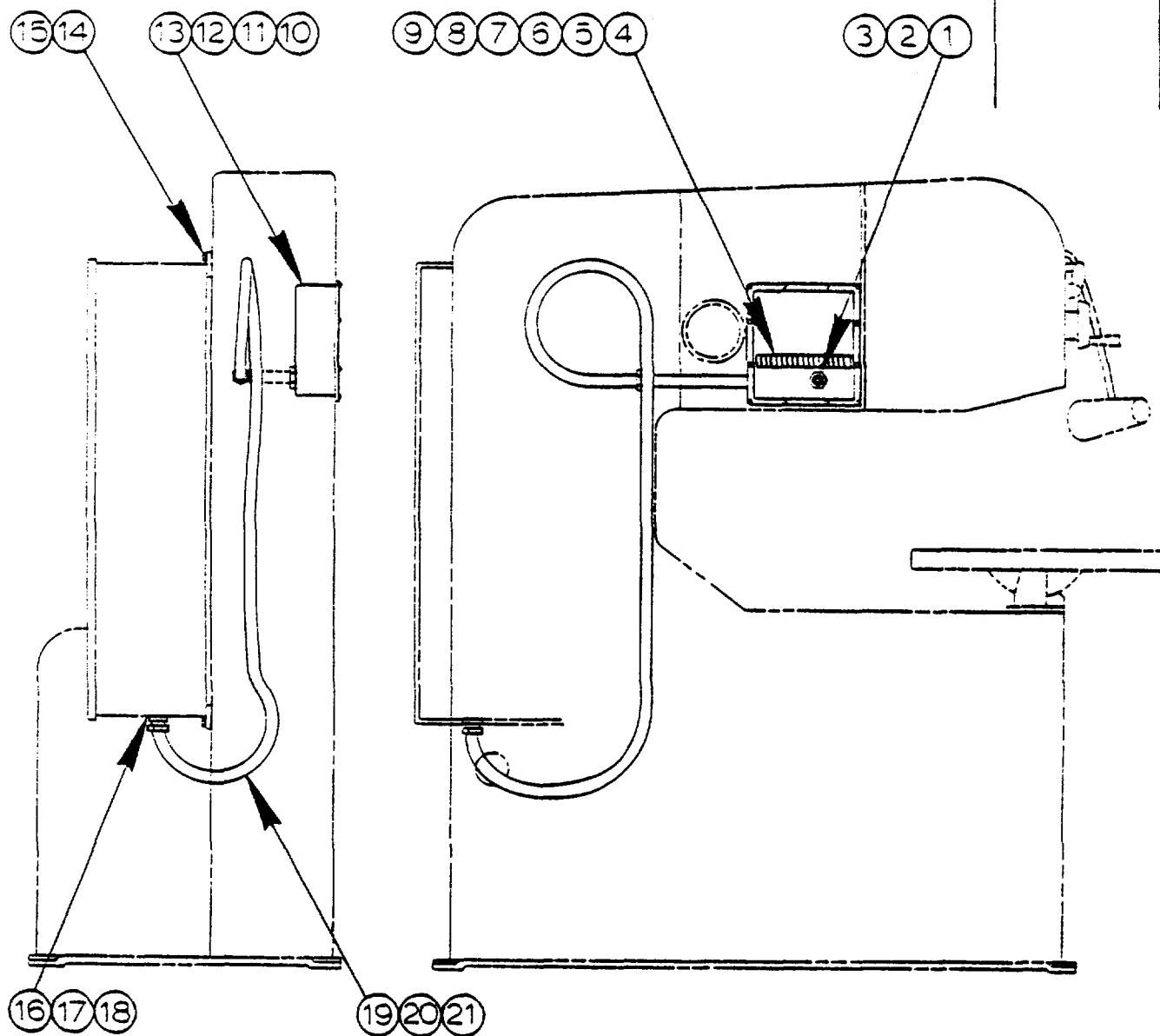

<u>MODEL</u>	<u>FIRST MACH.</u>	<u>LAST MACH.</u>
3612-2	398-78101	
3613-20	399-78101	
3612-2H	400-78101	
3612-2H3	401-78101	

ELECTRICAL ASSEMBLY
C-6-67 CM-6-57

CODE NO.	C-6-67
	CM-6-57

ELECTRICAL ASSEMBLY

INDEX NO.	CATALOG NO.	DESCRIPTION	UNITS PER ASS'Y
Ref.	507135	Electrical Assembly	
Ref.	507601	Electrical Assembly (Extra Work Height)	
1	090-156076	. Bond Nut 3/4"	2
2	090-144809	. Washer 3/4"	2
3	135-095214	. "O"-Ring 3/4"	2
4	091-349688	. Terminal Block	15
5	091-349704	. End Section	1
6	091-349696	. Channel Clamp	1
7	091-349712	. Channel	A.R.
8	091-994657	. Screw, Rd. Hd. Self-Tap R10-24NC x 3/8	2
9	091-993196	. Washer, Spring Lock #10 Med	2
10	095-070579	. Pushbutton Box (507135)	Use
	095-076006	. Pushbutton Box (507601)	One
11	093-075034	. Gasket	1
12	091-990093	. Screw, Truss Hd. Mach. 48-32NC x 3/8	12
13	091-993188	. Washer, Spring Lock #8 Med	12
14	091-980259	. Screw, Hex. Hd. Cap 5/16-18NC x 1/2	8
15	091-993238	. Washer, Spring Lock 5/16" Med	8
16	090-145459	. Connector, 1/2" Sealtite	2
17	090-144114	. Flange Washer 1/2"	2
18	090-145053	. "O"-Ring 1/2"	2
19	091-971580	. Conduit, 3/4" Sealtite	A.R.
20	090-146861	. Connector, 3/4" Sealtite	1
21	090-165499	. Connector, Female Straight	1
Following Items Not Shown:			
	091-971804	. Wire, #10 Flamenal Blue	A.R.
	091-971903	. Wire, #14 Red, Nylon Jacket	A.R.
	091-971879	. Wire, #14 White Nylon Jacket	A.R.
	091-994749	. Screw, Self Tap Rd. Hd. 1/4-20NC x 1/2 (507601)	6
	091-993212	. Washer, Lock 1/4" Std. (507601)	6

NEW DRG. C.A.K. 7-13-78
REVISIONS

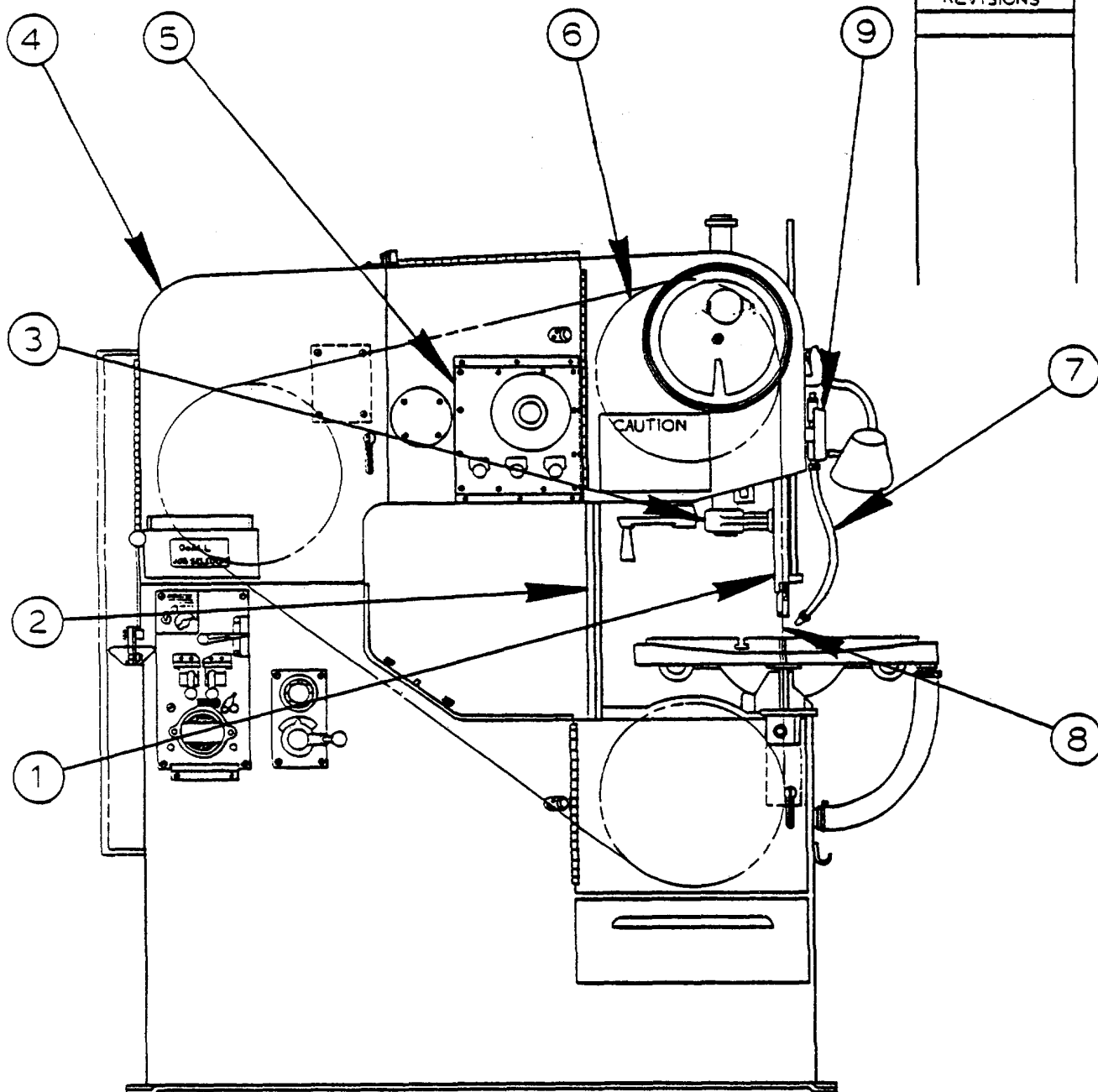

	<u>MODEL</u>	<u>FIRST MACH.</u>	<u>LAST MACH.</u>
	3612-2	398-78101	
	3613-20	399-78101	
C-2-140	3612-2H	400-78101	
CM-2-89	3612-2H3	401-78101	

EXTRA WORK
HEIGHT ASSEMBLIES

CODE NO.	C-2-140
	CM-2-89

EXTRA WORK HEIGHT ASSEMBLIES

INDEX NO.	CATALOG NO.	DESCRIPTION	UNITS PER ASS'Y
Ref.	095-075438	Extra Work Height Assembly(3618-2,3618-20,3618-2H)	
Ref.	095-075446	Extra Work Height Assembly(3624-2,3624-20,3624-2H)	
Ref.	095-075453	Extra Work Height Assembly(3630-2,3630-20,3630-2H)	
Ref.	095-075461	Extra Work Height Assembly(3618-2H3)	
Ref.	095-075479	Extra Work Height Assembly(3624-2H3)	
Ref.	095-075487	Extra Work Height Assembly(3630-2H3)	
1	094-077344	. Saw Band Guard Assembly(18" Work Height)	Use
	094-071966	. Saw Band Guard Assembly(24" Work Height)	
	094-090933	. Saw Band Guard Assembly(30" Work Height)	One
2	094-077336	. Saw Band Guard Assembly(3618-2H3).....	Use
	094-072717	. Saw Band Guard Assembly(3624-2H3)	
	094-090941	. Saw Band Guard Assembly(3630-2H3)	One
3	095-059192	. Auxiliary Post Assembly (18" Work Height)	Use
	095-053799	. Auxiliary Post Assembly (24" Work Height)	
	095-075586	. Auxiliary Post Assembly (30" Work Height)	One
4	095-075552	. Frame Weldment Assembly(3618-2,3618-20,3618-2H)	Use
	095-075560	. Frame Weldment Assembly(3624-2,3624-20,3624-2H)	
	095-075578	. Frame Weldment Assembly(3630-2,3630-20,3630-2H)	
	095-075495	. Frame Weldment Assembly(3618-2H3)	
	095-075503	. Frame Weldment Assembly(3624-2H3)	
	095-075511	. Frame Weldment Assembly(3630-2H3)	One
5	095-076014	. Electrical Assembly(See Detail)	1
6	094-082369	. Head Sub-Assembly(3618-2H3)	Use
	094-091147	. Head Sub-Assembly(3624-2H3)	
	094-091134	. Head Sub-Assembly(3630-2H3)	One
7	091-210252	. Air Hose (24" Machines Only)	Use
	091-210286	. Air Hose (30" Machines Only)	One
8	091-444281	. Saw Band (18" Machines Only)	Use
	091-420281	. Saw Band (24" Machines Only)	
	091-498568	. Saw Band (30" Machines Only)	One
* 9	093-063162	. Post Elevating Sub-Assembly(3618-2,3618-20,3618-2H)	Use
	093-056877	. Post Elevating Sub-Assembly(3624-2,3624-20,3624-2H)	
	093-076693	. Post Elevating Sub-Assembly(3630-2,3630-20,3630-2H)	One
10	091-228361	. Door Latch Assembly (24" & 30" Machines) (Nat Shown)	1

*Starred Items are Shown in Detail on Following Pages.

NEW ORG
DATE 9-20-77
REVISIONS

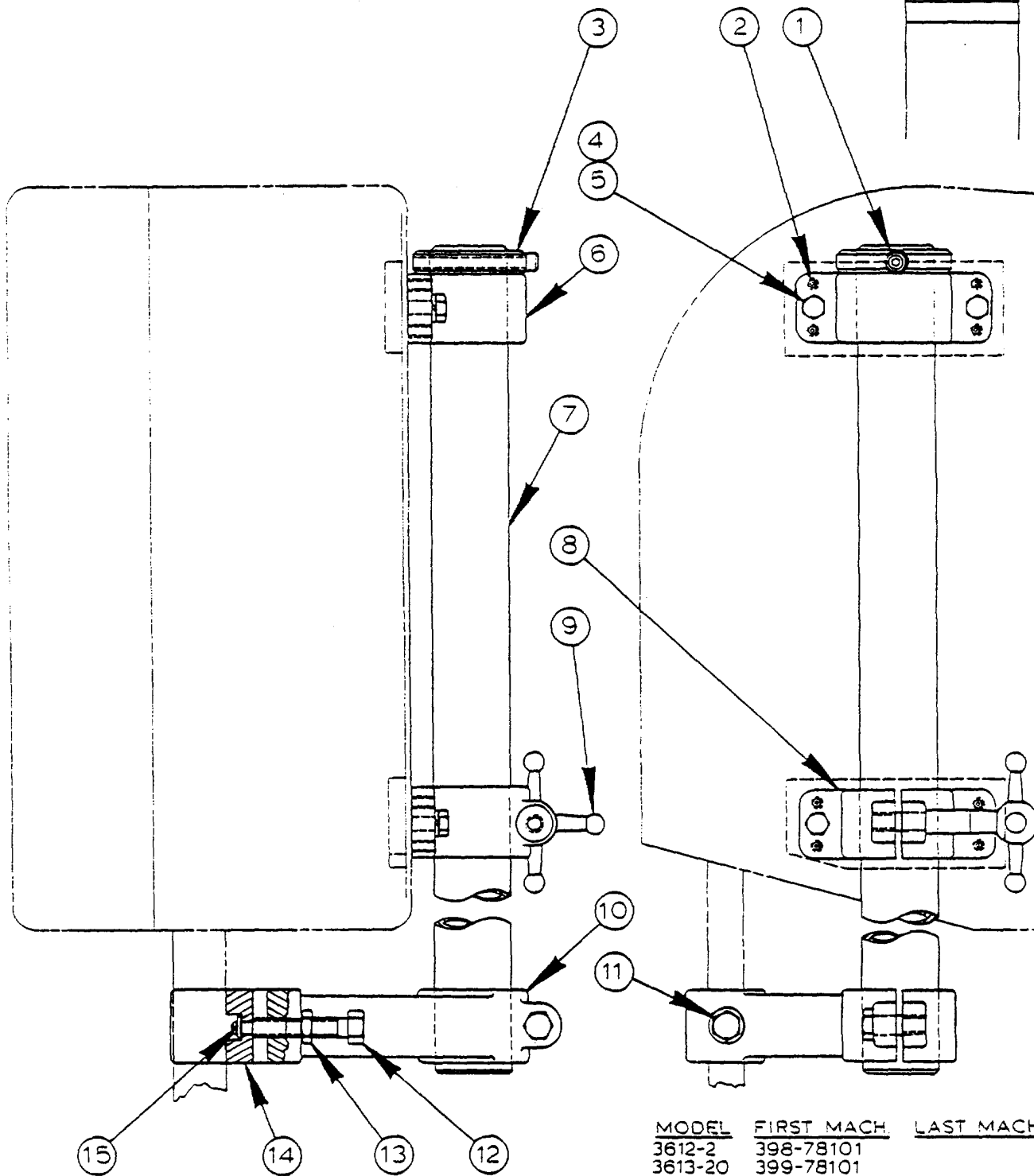

MODEL	FIRST MACH.	LAST MACH.
3612-2	398-78101	
3613-20	399-78101	
3612-2H	400-78101	
3612-2H3	401-78101	

C-2-141 CM-2-90

AUXILIARY POST ASSEMBLY
(EXTRA WORK HEIGHT)

CODE NO. C-2-141
CM-2-90

AUXILIARY POST ASSEMBLY
 (Extra Work Height)

INDEX NO.	CATALOG NO.	DESCRIPTION	UNITS PER ASS'Y
Ref.	095-059192	Auxiliary Post Assembly (18" Work Height)	
Ref.	095-053799	Auxiliary Post Assembly (24" Work Height)	
Ref.	095-075586	Auxiliary Post Assembly (30" Work Height)	
1	091-982884	. Screw, Soc. Hd. Cap 3/8-16NC x 3 1/4"	1
2	091-984393	. Screw, Soc. Set 5/16-18NC x 3/4	8
3	113-014237	. Post Collar	1
4	091-980482	. Screw, Hex. Hd, Cap 3/8-16NC x 1 1/2"	4
	091-993329	. Washer, Lock 3/8" Std.	4
6	090-324633	. Upper Post Guide	1
7	093-056836	. Auxiliary Post (18" Work Height)	Use
	093-056844	. Auxiliary Post (24" Work Height)	
	093-056851	. Auxiliary Post (30" Work Height)	One
8	090-324625	. Lower Post Guide	1
9	090-076290	.. Starwheel Sub-Assembly	1
	106-011034	.. Starwheel	1
	090-042615	.. Roll Pin	1
	113-014229	.. Clamp Screw	1
10	090-243379	. Post Support Arm	1
11	091-980672	. Screw, Hex. Hd. Cap 1/2-13NC x 1 1/2"	1
12	113-014195	. Back-Up Pad Screw 1/2-13NC x 4 1/8"	1
13	091-991323	. Nut, Hex. Jam 1/2-13NC	1
14	113-013098	. Post Back-up Pad	1
15	135-096162	. Retaining Ring	1

NEW ORG.
C.A.K. 9-20-77
REVISIONS

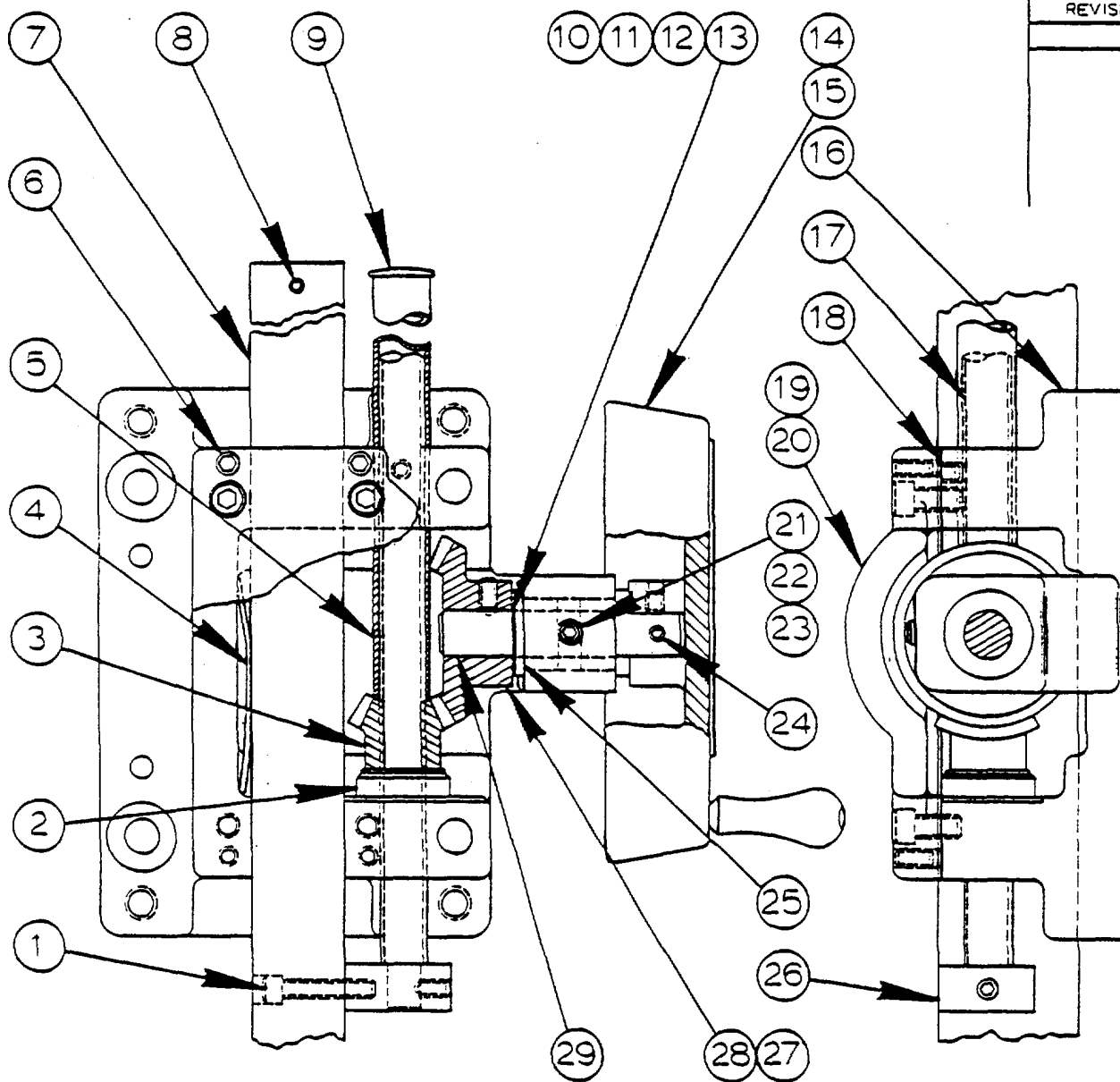

<u>MODEL</u>	<u>FIRST MACH.</u>	<u>LAST MACH.</u>
3612-2	398-78101	
3613-20	399-78101	
3612-2H	400-78101	

C-2-142 CM-2-91
 POST ELEVATING SUB-ASSEMBLY
 (EXTRA WORK HEIGHT)

CODE NO.	C-2-142
	CM-2-91

DISC CUTTER ASSEMBLY

INDEX NO.	CATALOG NO.	DESCRIPTION	UNITS PER ASS'Y
Ref.	093-063162	Post Elevating Sub-Assembly (18" Work Height)	
Ref.	093-056877	Post Elevating Sub-Assembly (24" Work Height)	
Ref.	093-076693	Post Elevating Sub-Assembly (30" Work Height)	
1	091-982256	. Screw, Soc. Hd. Cop -#10-24NC x 1	2
2	135-028108	. Thrust Bearing	1
3	091-209254	. Gear	1
4	105-013064	. Spring.....	1
5	091-428169	. Tube (18" Work Height)	Use
	091-428177	. Tube (24" Work Height)	
	091-428185	. Tube (30" Work Height).....	One
6	091-985903	. Screw, Soc. Set 1/4-20NC x 1/2 (1/2" Dog Pt.)	4
7	093-057511	. Post (18" Work Height)	Use
	093-057529	. Post (24" Work Height)	
	093-057537	. Post (30" Work Height)	One
8	090-042250	. Roll Pin ,	1
9	091-235812	. Plug Button.....	1
10	091-333104	. Shim .035 Thk	A.R.
11	091-333112	. Shim .0149 Thk	A.R.
12	091-333120	. Shim .005 Thk	A.R.
13	091-335138	. Shim .003 Thk	A.R.
14	090-386434	. Handwheel	1
15	091-046904	. Handle	1
16	094-017688	. Housing.....	1
17	093-057545	. Screw (18" Work Height)	Use
	093-057552	. Screw (24" Work Height)	
	093-057560	. Screw (30" Work Height)	One
18	091-984096	. Screw, Soc, Set #10-24NC x 3/16	1
19	090-386442	. Cover.....	1
20	091-982363	. Screw, Soc. Hd. Cap 1/4-20NC x 1/2	4
21	0971-407650	. Friction Plug	1
22	090-039710	. Spring.....	1
23	091-984229	. Screw, Soc. Set 1/4-20NC x 1/4 "	Use
	091-235762	. Screw, Soc. Set(Nyloc) #8-32NC x 3/8	One
24	090-042599	. Roll Pin	1
25	091-209221	. Bearing	2
26	091-209205	. Block	1
27	090-144353	. Bevel Gear.....	1
28	091-154278	. Screw, Soc. Set #10-24NC x 1/4 (Self-Locking)	3
29	091-209239	. Shaft	1

NEW DRG.
S.C.L. 0-25-74
REVISIONS
C.A.K. 1-2-77
C.A.K. 4-21-77

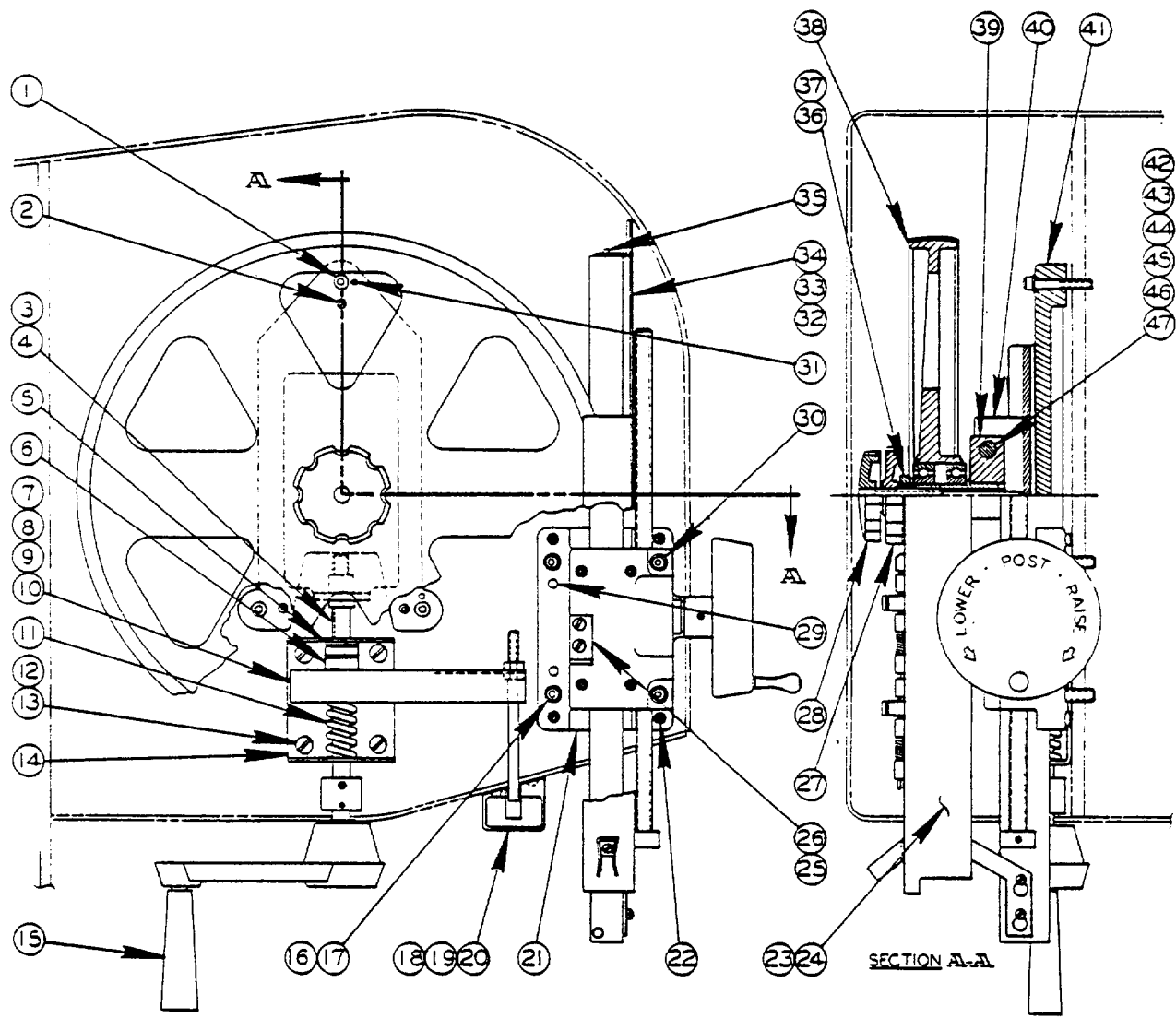

MODEL	FIRST MACH	LAST MACH
3612-0	277-70830	277-751729
3613-0	278-70287	278-77825
3612-H	288-70310	288-75436
3612-H	272-70208	272-77373
3612-H	382-77101	
3613-H	381-77101	
3613-20	399-78101	
3612-2H	400-78101	

C-2-72 CM-2-64

HEAD ASSEMBLY

HEAD ASSEMBLY

INDEX NO.	CATALOG NO.	DESCRIPTION	UNITS PER ASS'Y
Ref.	500372	Head Assembly	
1	091-982637	. Screw, Soc. Hd. Cap, 5/16-18 NC x 1-3/4"	3
2	091-986133	. Screw, Soc. Set, 5/16-18 NC x 1"	3
3	091-181198	. Tension Shaft Sub-Assembly	1
4	090-042599	. Roll Pin	1
5	091-992669	. Washer, Flat 1/2" Std	2
6	135-028108	. Bearing	1
7	091-422501	. Band Tension Pointer	1
8	091-440610	. Angle	1
9	091-991232	. Nut, Hex. Jam 5/16-18 NC	2
10	091-318089	. Locative, Grade HV	A.R.
11	135-087617	. Spring	1
12	091-990226	. Screw, Truss Hd. Mach., 1/4-20 NC x 5/8"	4
13	091-993212	. Washer, Lock 1/4 Std	7
14	093-059442	. Bracket	1
15	090-285271	. Handle Assembly	1
11	091-982819	. Screw, Soc. Hd. Cap, 3/8-16 NC x 1-1/2"	2
17	091-993329	. Washer, Lock 3/8 Std	4
18	091-069195	. Bracket	1
19	091-988519	. Screw, Rd. Hd. Mach., #8-32 NC x 1/4"	2
20	091-993188	. Washer, Lock 08 Std	2
21	090-390550	. Post Elevating Sub-Assembly (See Detail)	1
22	091-218719	. Screw, Soc. Set, (Self-Locking)	4
23	094-065117	. Post Saw Band Guard Assembly	1
24	091-986984	. Screw, Fillet Hd. Mach., #10-24 NC x 1/2"	2
25	091-398115	. Stop	1
26	091-988667	. Screw, Rd. Hd. Mach., #10-24 NC x 5/16"	2
27	105-011092	. Upper Wheel Tilting Locknut	1
28	091-306761	. Tilting Screw Sub-Assembly	1
29	135-004455	. Dowel Pin	2
30	091-982876	. Screw, Soc. Hd. Cap, 3/8-16 NC x 3"	2
31	090-042631	. Roll Pin	2
32	093-051357	. Guard Bracket Assembly	1
33	091-988519	. Screw, Rd. Hd. Mach., #8-32 NC x 1/4" (Plated)	2
34	091-992578	. Washer #8 Std	2
35	091-053041	. Roll Pin	1
36	105-015069	. Bearing Locknut	1
37	105-015077	. Bearing Lockwasher	1
38	135-051274	. Upper Saw Wheel Assembly	1
	135-022648	.. Upper Saw Wheel	1
	135-022705	.. Wheel Tire	1
	105-015085	.. Ball Bearing	2
39	093-023463	. Wheel Hinge(See Detail)	1
40	094-018157	. Slide Sub-Assembly	1
41	095-046215	. Head Casting	1
42	091-206276	. Pin	1
43	135-096139	. Retaining Ring	2
44	091-333104	. Shim	A.R.
45	091-333112	. Shim	A.R.
46	091-333120	. Shim	A.R.
47	091-333138	. Shim	A.R.

REVISED AND REDRAWN
SCL 12-10-74

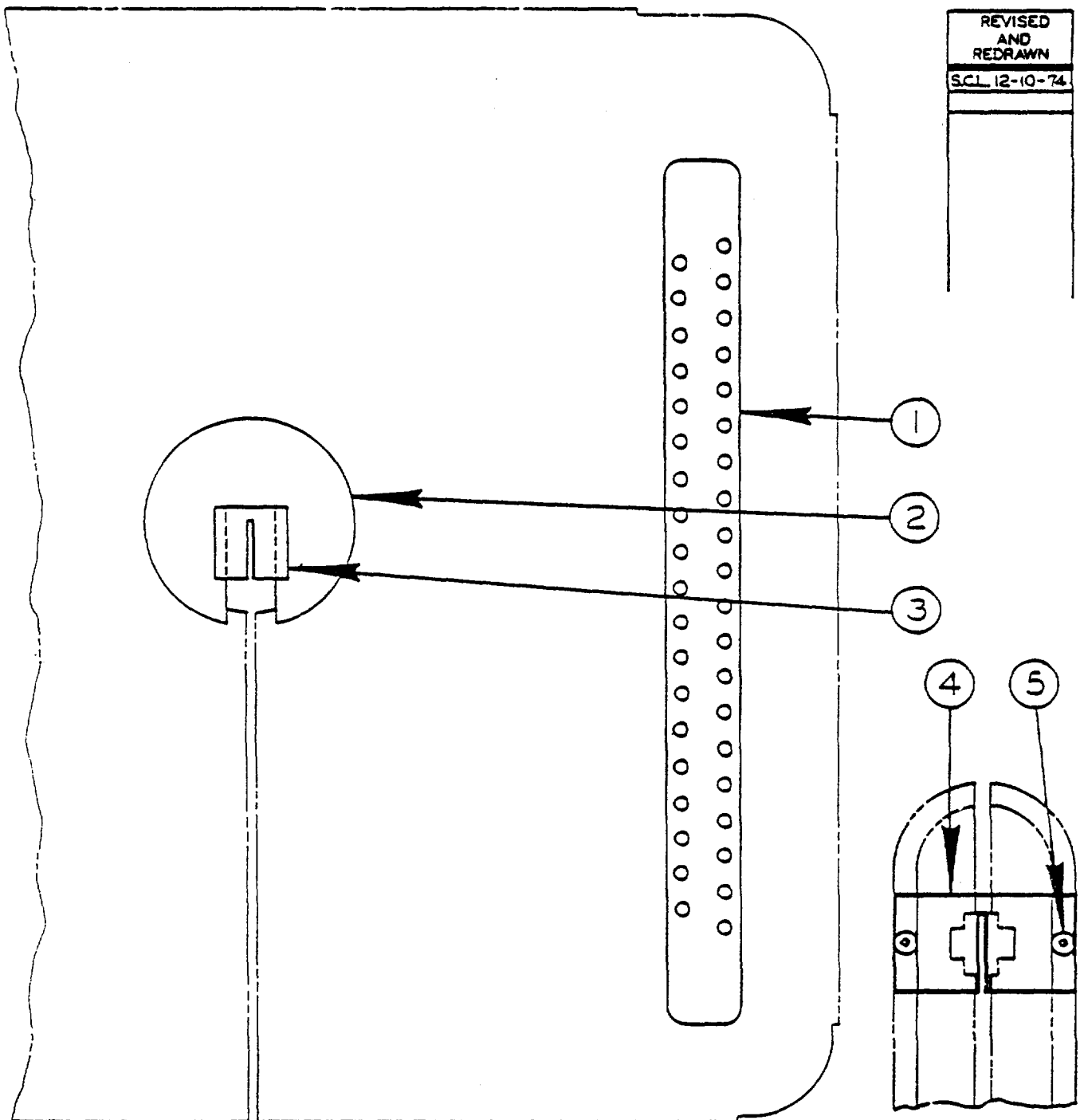

C-10-23 CM-10-33 Z-10-12

HEAVY WORK SLIDES

HEAVY WORK SLIDES

INDEX NO.	CATALOG NO.	DESCRIPTION	UNITS PER ASS'Y
Ref.	090-450040	Heavy Work Support Assembly (1612, 1612-0, 1612-1, 2013, 2013-0, 2013-10, 2612-1, 2614-1, 3612, 3612-1, 3613-0, 3613-10, 3613-1, 2013-1)	
Ref.	135-052470	Heavy Work Support Assembly (1613-2, 2613-2, 3613-2, 6013-2, ZS-3620, ZV-3620, ZW-3620)	
Ref.	094-006921	Heavy Work Slide Assembly (2612-2H)	
1	106-233190	. Work Transport Bar	2
2	090-279506	. Center Plate (Assembly #090-450040 Only)	1
3	106-234529	. Center Support (Assemblies #090-450040 & 135-052470)	1
4	091-178145	. Center Support (Assembly #094-006921 Only)	1
5	091-983205	. Screw, FI Hd. Soc. Cap 1/4-20NC x 3/4 (Assembly #094-006921 Only)	2

REVISED AND REDRAWN
S.W. 2-16-74

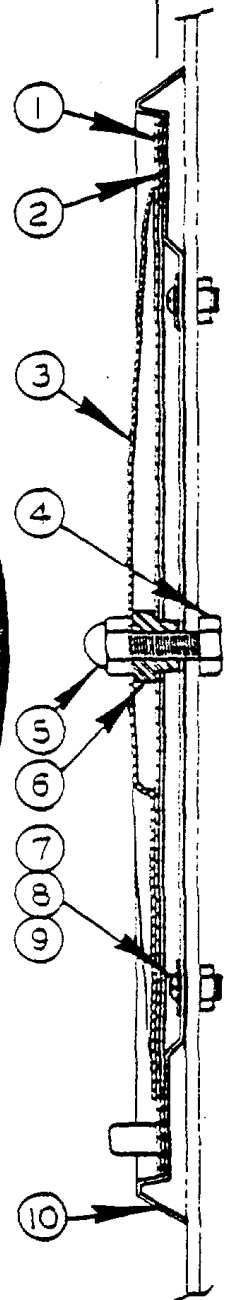
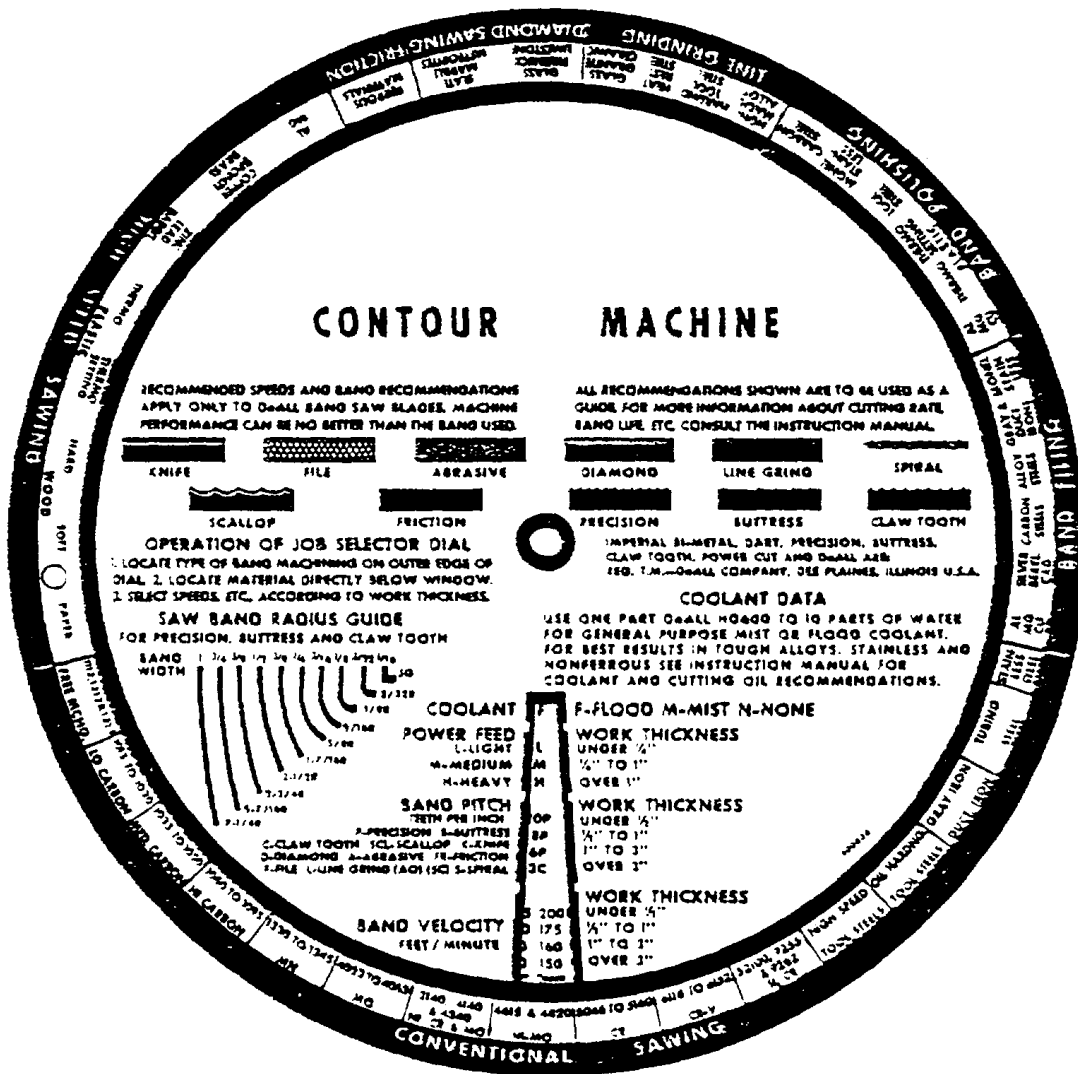

C-8-104 CM-8-53 Z-6-54

JOB SELECTOR ASSEMBLY

JOB SELECTOR

INDEX NO.	CATALOG NO.	DESCRIPTION	UNITS PER ASS'Y
Ref.	090-468174	Job Selector (1612-U, 3012-U, 1611-H, 2612-1H, 2013, 2013-0, 2012-A, 2012-AT, 1612-0, 3613-0, 1612, 3612, 2013-1, 2013-10, 2012-1A, 2012-1AT, 3612-1H, 3612-1, 3613-10)	
*Ref.	090-435603	Job Selector (1612-1, 3613-1, 2612-1, 2613-2, 6013-2, 2618-4, HS-6013, ZW-3620, ZV-3620, ZS-3620)	
1	090-220781	. Job Selector Dial	1
2	106-143043	. Outer Edge Felt	4
3	094-008380	. Job Selector Plate	1
4	091-990283	. Screw, Truss Hd. Mach. 5/16-18 NC x 3/4	1
	*091-980276	. Screw, Hex. Hd. Cap. 5/16-18 NC x 3/4	1
5	090-044496	. Acorn Nut 5/16-18 NC	1
6	106-144017	. Bushing	Use
	*090-027012	. Bushing	One
*7	091-988907	. Screw, Rd. Hd. Mach. 1/4-20 NC x 1/4	4
*8	091-993741	. Washer, Lock Shakeproof 1/4 Internal	4
*9	091-991141	. Nut, Hex. Jam 1/4-20 NC	4
*10	090-426727	. Job Selector Frame	1

NOTE: Job Selectors #090-468174 & #090-435603, First Used 9/17/62. Before This Date 4094-008380 Plate end #090-220781 Dial, Must Be Replaced Together As A Unit.

***NOTE: Starred Items Used Only On Assembly #090-435603.**

***NOTE: Last Used On Models:**

<u>MODEL</u>	<u>LAST MACH.</u>
1613-2	150-69593
3613-2	151-69515
1612-3	152-691017
2613-3	198-69361
3612-3	153-691054
6013-3	199-70125
1612-H	288-69204
2612-H	284-69135
2612-2H	206-69308
3612-H	272-69152

O.S.H.A. REQUIREMENT

WIRE WORK LAMP DIRECT TO CONTROL BOX. MOUNT LAMP SWITCH ON SIDE OF CONTROL BOX OR THE CONTROL PANEL.

NOTE:

LAMP ASS'Y. #406141 WILL REPLACE ALL PREVIOUS "MOFFATT" PLASTIC LAMPS.

REVISIONS
REDRN. 5-23-75 W.S.

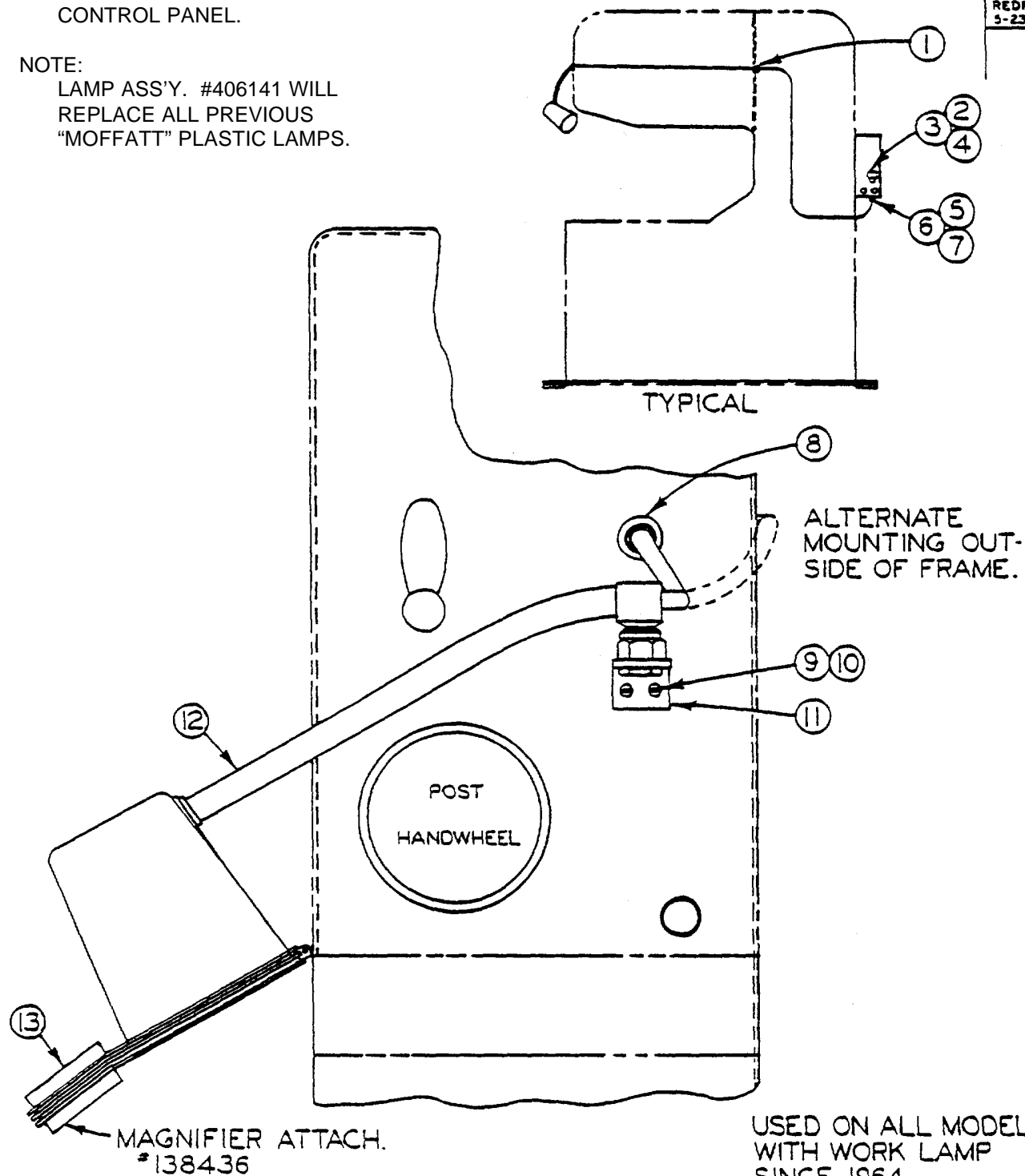

USED ON ALL MODELS WITH WORK LAMP SINCE 1964.

C-8-8 CM-8-31 PS-8-103 TF-4-100 F9-6.1 Z-7-61

LAMP & MAGNIFIER ASSEMBLIES

C-8-8

CM-8-31

PS-8-103

CODE NO. TF-4-100

F9-6.1

Z-7-61

LAMP & MAGNIFIER

INDEX NO.	CATALOG NO.	DESCRIPTION	UNITS PER ASS'Y
Ref.	094-061413	. Lamp Assembly	
1	090-157454	. Bushing	1
2	090-152455	. Selector Switch, 2-Position	1
3	091-048207	. Contact Block	1
4	091-333591	. Legend Plate	1
5	090-145459	. Cord Grip Connector	1
6	090-144114	. Washer	1
7	090-145053	. "O"-Ring	1
8	090-151390	. Cord Grip	1
9	091-988659	. Screw, Rd. Hd. Mach. #10-24 NC x 1/4"	2
10	091-993196	. Washer, Lock #10 Std	2
11	091-025049	. Bracket	1
12	091-384529	. Lamp Sub-Assembly, 19" Flexible Cable, 11'-1/2" Connecting Cord	1
13	091-384362	. Magnifier Attachment, Mounts to Lampshade on Lamp Part #091-384529	1

NEW DRG.
Q.E. 8-20-68
REVISIONS
SCL 7-17-74

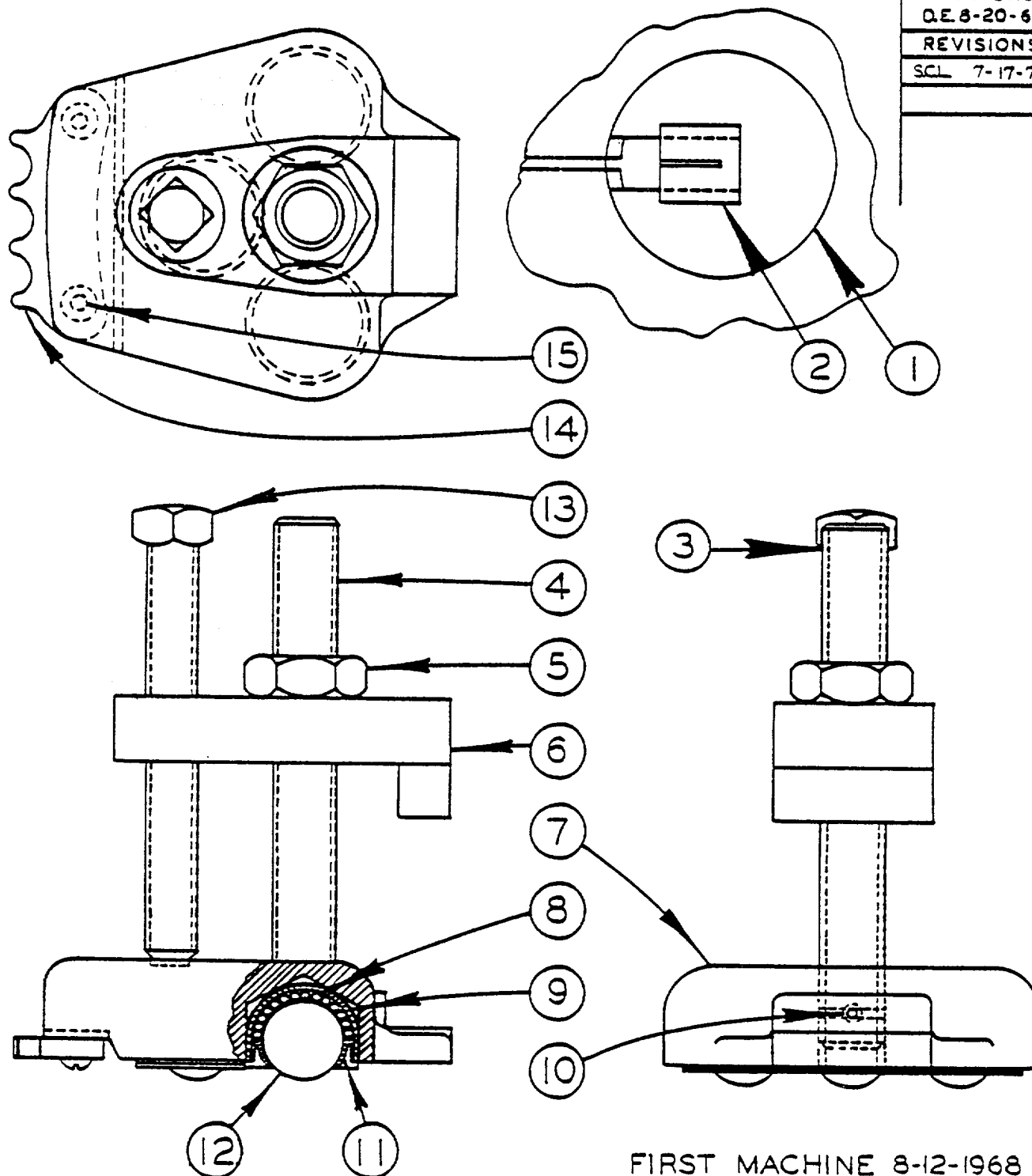

HEAVY
PARALLEL WORK CLAMP

HEAVY
 PARALLEL WORK CLAMP ASSEMBLY

INDEX NO.	CATALOG NO.	DESCRIPTION	UNITS PER ASS'Y
REF.	090-450099	Parallel Work Clamp Assembly	
1	090-279506	. Center Plate	1
2	106-244130	. Center Support	1
3	090-376294	. Parallel Work Clamp Sub-Assembly	4
4	106-244155	.. Clamp Stud	1
5	091-991356	.. Nut, Hex. 5/8-11 NC.....	1
6	106-243074	.. Parallel Arm	1
7	090-376286	.. Clamp Body.....	1
8	106-245053	.. Steel Ball.....	195
9	106-243062	.. Ball Cup	3
10	091-984112	.. Screw, Soc. Set 10-24 NC x 3/8.....	1
11	135-037976	.. Ball Retainer Ring	3
12	106-245046	.. Steel Ball	3
13	106-245087	.. Set Screw.....	1
14	105-133136	.. Work Holding Jaw Sprocket	1
15	091-986893	.. Screw, Rd. Hd. Mach. 10-24 NC x 1/2.....	4

NEW DRG.
S.W. 4-3-70
REVISIONS
S.C.I. 6-8-73
S.C.I. 10-25-74
C.A.K. 1-14-77
C.A.K. 3-8-78

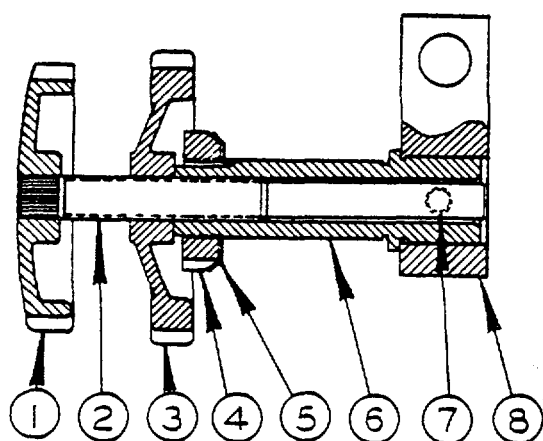

WHEEL HINGE ASSEMBLY

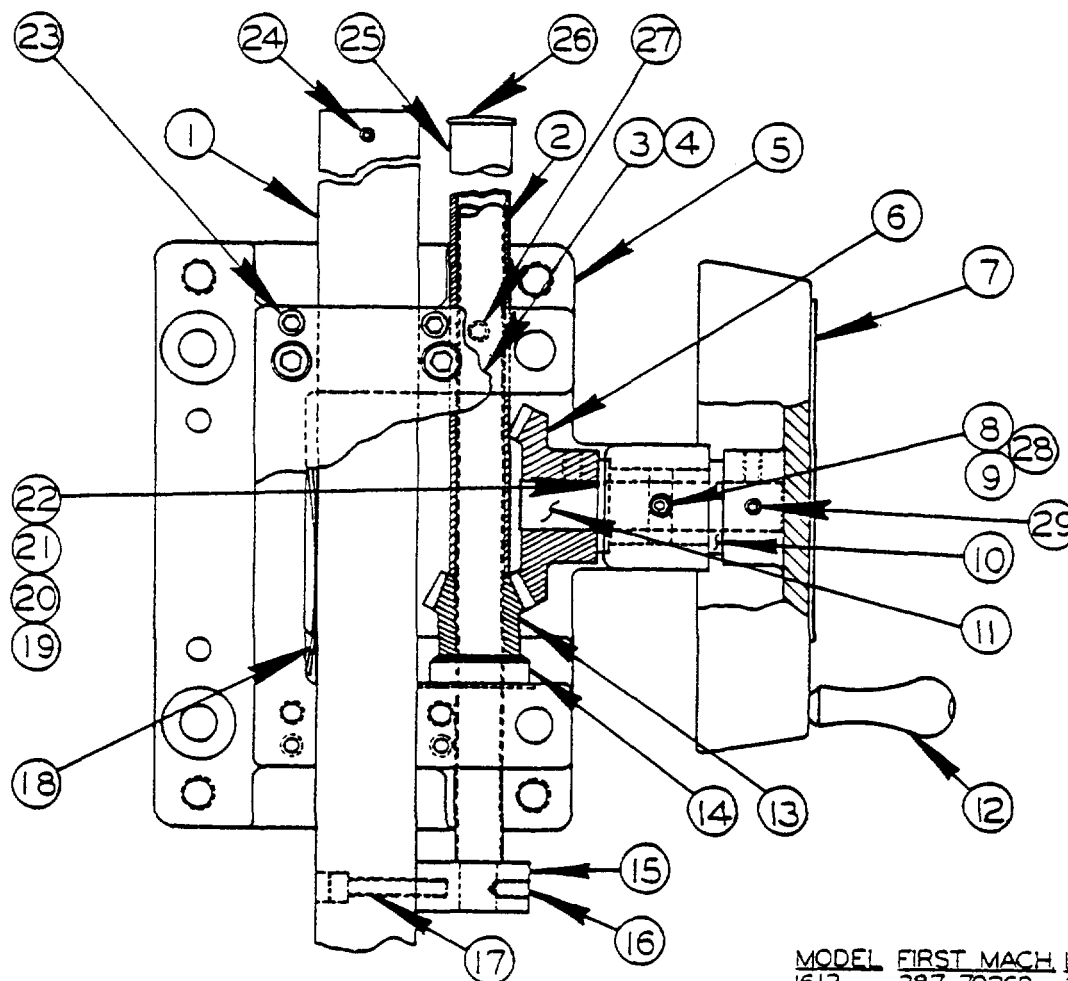

C-2-65 CM-2-79

POST ELEVATING MECHANISM

MODEL	FIRST MACH	LAST MACH
1612	287-70269	287-76450
3612	291-70150	291-77235
1612-0	277-70830	277-751728
3613-0	278-70287	278-77825
1612-H	288-70310	288-75436
3612-H	272-70208	272-77373
3612-1	380-77101	
3613-10	381-77101	
3612-1H	382-77101	
3612-2	398-78101	
3613-20	399-78101	
3612-2H	400-78101	

POST ELEVATING MECHANISM

INDEX NO.	CATALOG NO.	DESCRIPTION	UNITS PER ASS'Y
Ref.	090-390550	Post Elevating Sub-Assembly	
1	090-391186	. Post.....	1
2	091-209247	. Screw.....	1
3	090-386442	. Cover	1
4	091-982363	. Screw, Soc. Hd. Cap, 1/4-20 NC x 1/2"	4
5	094-017688	. Housing	1
6	090-144353	. Gear	1
7	090-386434	. Handwheel	1
8	091-407650	. Friction Plug	1
9	090-039710	. Spring	1
10	091-209221	. Bearing	2
11	091-209239	. Shaft	1
12	091-046904	. Handle	1
13	091-209254	. Gear	1
14	135-028108	. Thrust Bearing	1
15	091-209205	. Block	1
16	091-154278	. Screw, Soc. Set (Nylok) 110-24 NC x 1/4"	3
17	091-982256	. Screw, Soc. Hd. Cap, #10-24 NC x 1"	2
18	105-013064	. Spring	1
19	091-333104	. Shim 20 Ga	A.R.
20	091-333112	. Shim 28 Ga	A.R.
21	091-333120	. Shim 005 Thk.	A.R.
22	091-333138	. Shim 003 Thk.	A.R.
23	091-985903	. Screw, Soc. Set, 1/4-20 NC x 1/2" (Half Dog)	4
24	090-042250	. Roll Pin	1
25	091-235804	. Tube	1
26	091-235812	. Plug Button	1
27	091-984096	. Screw, Soc. Set 110-24 NC x 3/16"	1
28	091-984229	. Screw, Soc. Set 1/4-20 NC x 1/4"	1
29	090-042599	. Roll Pin	1
Ref.		Wheel Hinge Assembly	
1	105-011084	. Tilting Screw Knob	1
2	091-206268	. Tilting Screw	1
3	105-011092	. Tilting Locknut	1
4	105-015069	. Locknut	1
5	105-015077	. Washer, Lock	1
6	105-014245	. Stud	1
7	091-984237	. Screw, Soc. Hd. Set 1/4-20 NC x 5/16	1
8	091-206243	. Block	1

REVISED AND REDRAWN
SGC 11-22-74

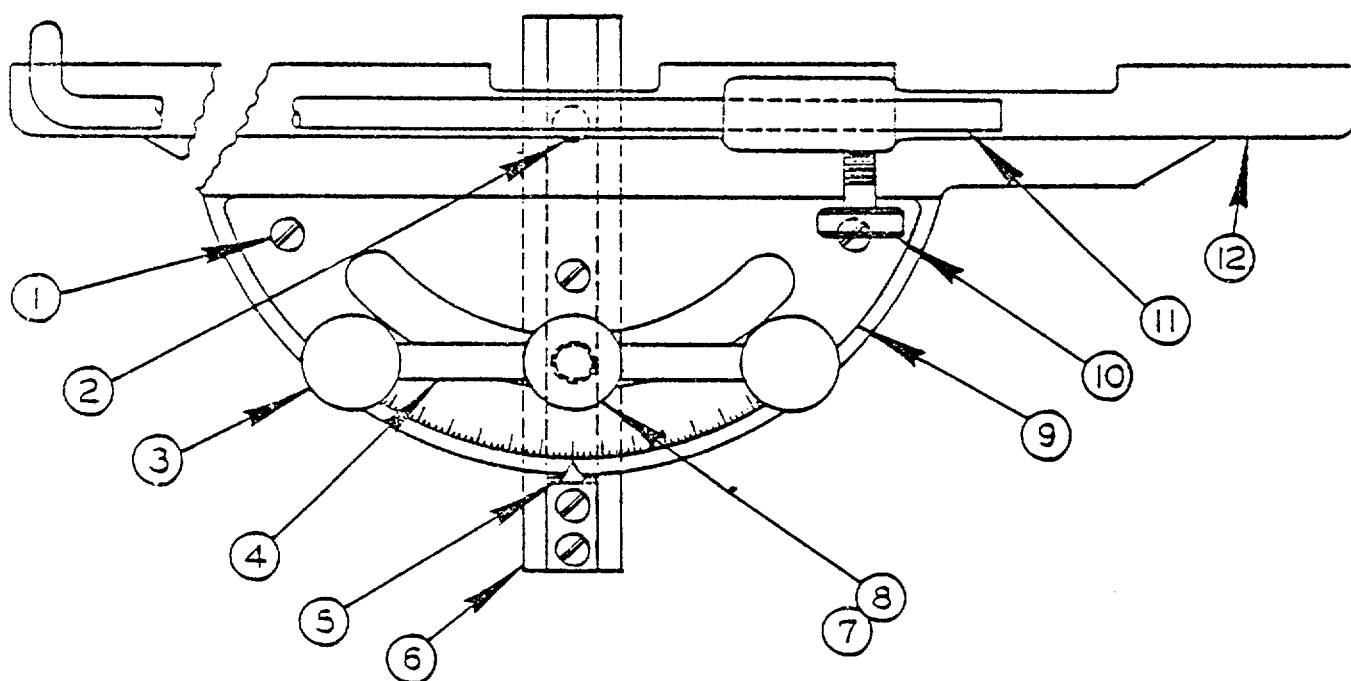

PROTACTOR WORK STOP
AND
ALIGNMENT GAGE ASSEMBLY

CM-10-7

D-1

CODE NO. CM-10-7

PROTRACTOR WORK STOP & ALIGNMENT ASSEMBLY

INDEX NO.	CATALOG NO.	DESCRIPTION	UNITS PER ASS'Y
REF.	090-514951	Protractor Work Stop & Alignment Assembly	
REF.	090-547589	Protractor Work Stop & Alignment Assembly	
1	091-988675	. Screw, Rd. Hd. Mach #10-24 NC x 3/8	5
2	114-004732	. Dowel Pin	1
3	091-339713	. Knob	2
	*114-115183	. Knob	2
4	090-116344	. Shaft	1
5	090-116336	. Pointer	1
6	090-253022	. Tee Nut	1
	*090-291329	. Tee Nut	1
7	090-116351	. Stud	1
	*091-011189	. Stud	1
8	091-992651	. Washer, Plain 7/16 S.A.E. Std	1
9	135-016145	. Protractor Plate	1
10	134-174010	. Thumb Screw	1
11	135-019768	. Gage Rod	1
12	090-514969	. Mitre Head	1

***NOTE: Starred Items Are Pert Of Assembly /090-547589**

REVISED
AND
REDRAWN
S.C.L. 11-25-74

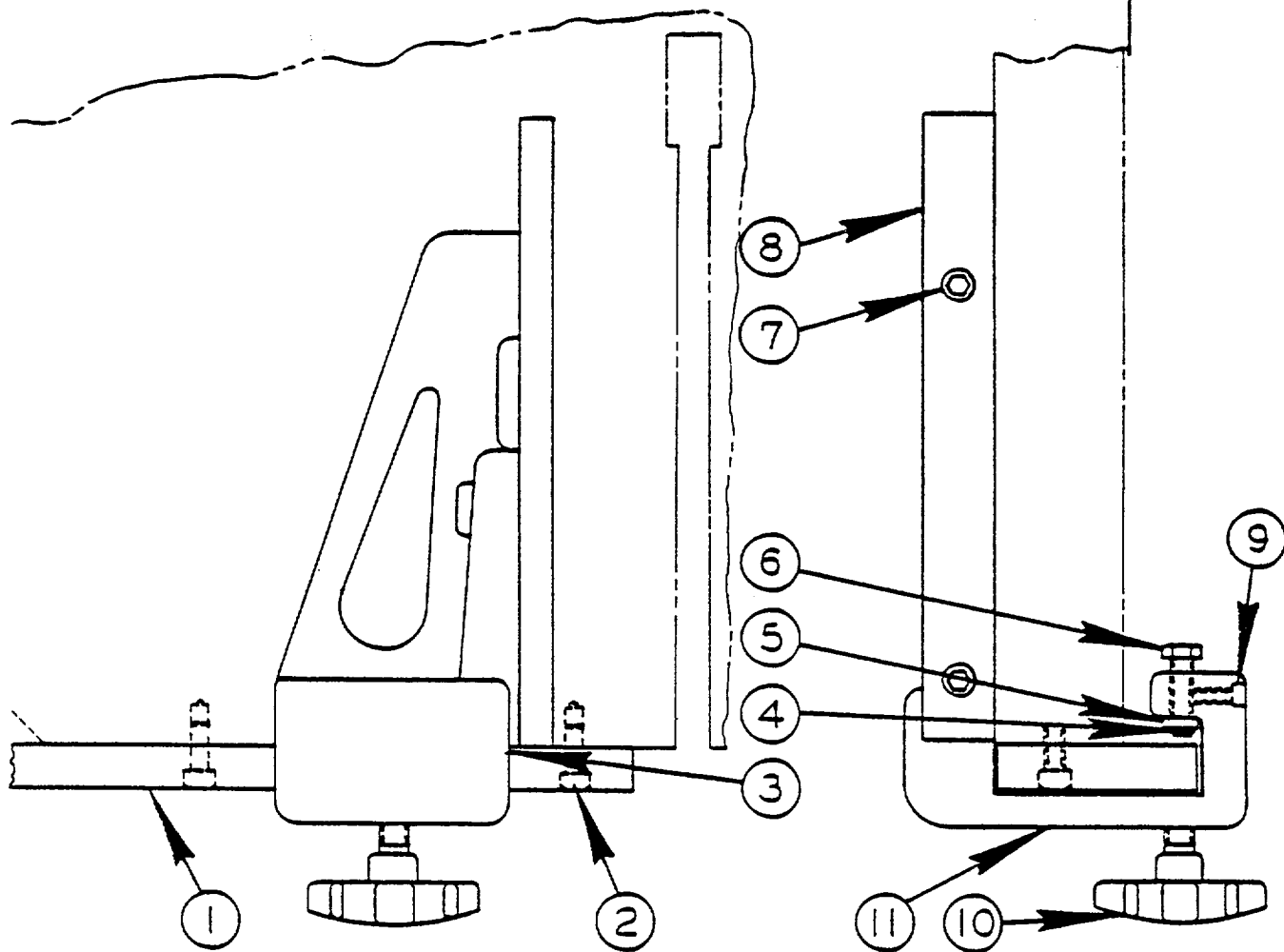

RIP FENCE ASSEMBLY

C-10-6 Z-9-5

RIP FENCE ASSEMBLY

INDEX NO.	CATALOG NO.	DESCRIPTION	UNITS PER ASS'Y
Ref.	090-477795	Rip Fence Assembly (26" Table)	
Ref.	135-005429	Rip Fence Assembly (30" Table)	
Ref.	135-005437	Rip Fence Assembly (24" Table)	
1	105-163026	. Clamp Guide (090-477795 & 135-005437	1
	111-163028	. Clamp Guide (135-005429)	1
2	091-982785	. Screw, Soc. Hd. Cap 3/8-16 NC x 3/4	2
3	135-051787	. Rip Fence Sub-Assembly (090-477795 & 135-005429)	1
	135-052512	. Rip Fence Sub-Assembly (135-005437)	1
4	134-065044	.. Spring Clip	2
5	105-163034	.. Clamp Bar	1
6	105-164032	.. Clamp Bar Screw.....	2
7	091-982785	.. Screw, Soc. Hd. Cap 3/8-16 NC x 3/4	2
8	135-005460	.. Work Guide (135-05178)	
	135-005486	.. Work Guide (135-052512)	1
9	091-984252	.. Screw, Sec. St 1/4-20 NC x 1/2.....	2
10	105-160048	.. Handwheel Assembly.	1
11	135-005445	.. Clamp (135-051787)	1
	135-005452	.. Clamp (135-052512)	1

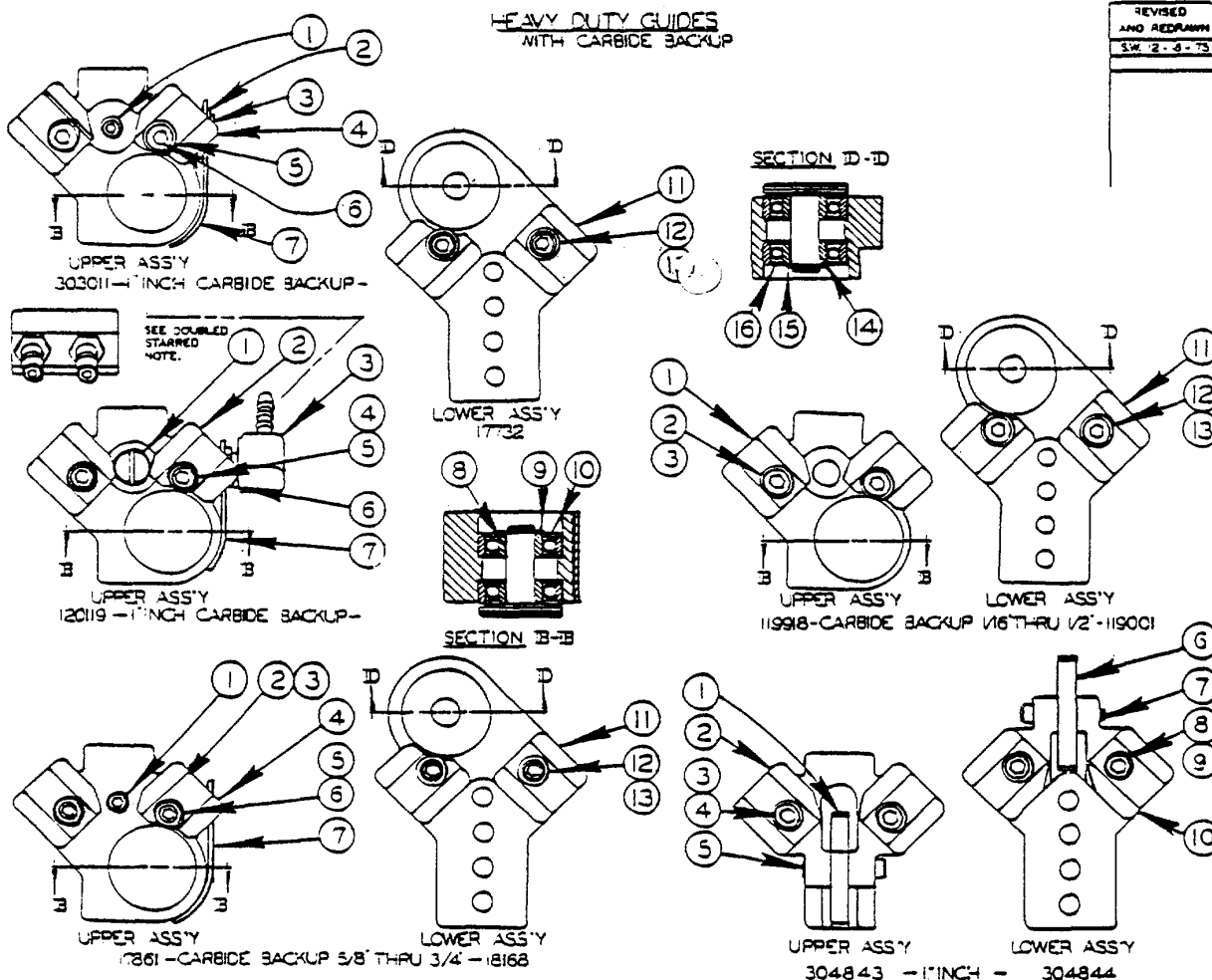
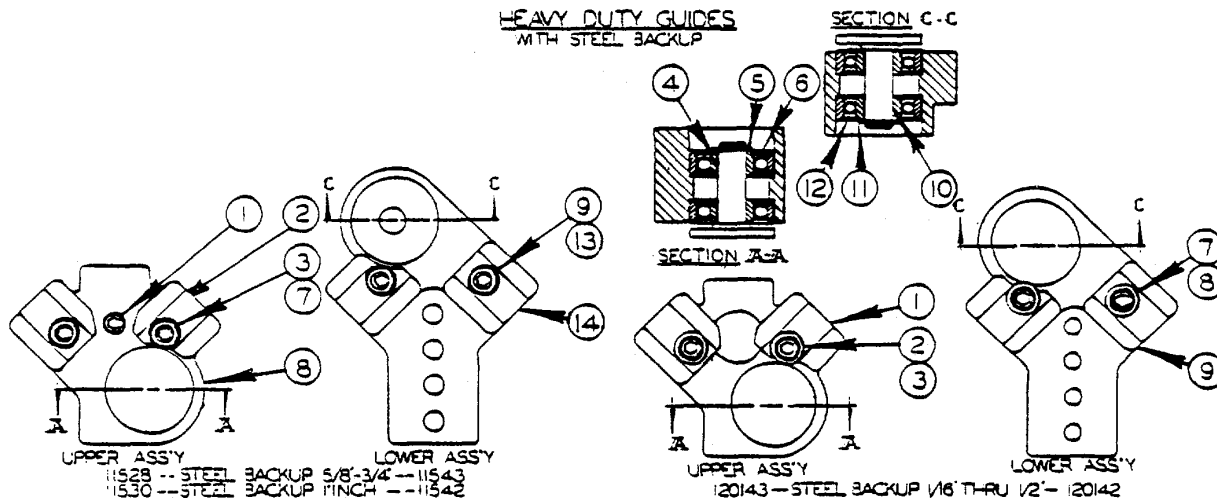

SAW GUIDE SELECTION
*121230

C-7-18 CM-7-23

#121230
SAW GUIDE SELECTION

INDEX NO.	CATALOG NO.	DESCRIPTION	UNITS PER ASS'Y	INDEX NO.	CATALOG NO.	DESCRIPTION	UNITS PER ASS'Y
HEAVY DUTY GUIDES STEEL BACKUP)							
Ref.	091-201434	Upper Saw Guide Ass'y. (1/18" to 1/2")		15	090-115411	. Retaining Ring	1
1	090-380767	. Upper Saw Guide Block	1	16	090-115296	. Bearing	2
2	091-982447	. Screw, Soc. Hd. Cap 1/4-20 NC x 1-1/4	2	Ref.	090-178617	Upper Saw Guide Ass'y. (5/8" to 3/4")	
3	134-085026	. Washer	2	1	091-984450	. Screw, Soc. Hd. Set 5/16-24 NF x 1/2	1
4	090-115403	. Bearing Cap	1	2	091-332023	. Pipe Plug	1
5	090-115411	. Retaining Ring	1	3	091-354415	. Lockout	1
6	090-115296	. Bearing	2	4	090-252529	. Upper Saw Guide Block	1
Ref.	091-201426	Lower Saw Guide Ass'y. (1/16" to 1/2")		5	091-982421	. Screw, Soc. Hd. Cap 1/4-20NC x 1..	2
7	091-982447	. Screw, Soc. Hd. Cap 1/4-20NC x 1-1/4	2	6	134-085026	. Washer	2
8	134-085026	. Washer	2	7	090-183377	. Guide Guard	1
9	090-377383	. Lower Saw Guide Block	1	8	090-172180	. Bearing Cap	1
10	090-115403	. Bearing Cap	1	9	090-115411	. Retaining Ring	1
11	090-115411	. Retaining Ring	1	10	090-115296	. Bearing	2
12	090-115296	. Bearing	2	Ref.	090-181686	Lower Saw Guide Ass'y. (5/8" to 3/4")	
Ref.	090-115288	Upper Saw Guide Ass'y (5/8" to 3/4")		11	090-252586	. Lower Saw Guide Block	1
Ref.	090-115304	Upper Saw Guide Ass'y (1")		12	091-982421	. Screw, Soc. Hd. Cap 1/4-20NC x 1.	2
1	091-984450	. Screw, Sac. Hd. Set 5/16-24 NF x 1/2	1	13	134-085026	. Washer	2
2	091-203695	. Sac. Hd. Pipe Plug	1	14	090-172190	. Bearing Cap	1
3	091-982421	. Screw, Sac. Hd. Cap 1/4-20NC x 1 (5/8" to 3/4")	2	15	090-115411	. Retaining Ring	1
	091-982447	. Screw Sac. Hd. Cap 1/4-20NC x 1-1/4" (1")	2	16	090-115296	. Bearing	2
4	090-115403	. Bearing Cap	1	Ref.	093-030112	Upper Saw Guide Ass'y. (1")	
5	090-115411	. Retaining Ring	1	1	091-984460	. Screw, Soc. Set 5/16-24 NF x 1/2" ...	1
6	090-115296	. Bearing	2	2	091-351445	. Locknut	1
7	134-085026	. Washer	2	3	091-332023	. Pipe Plug	1
8	090-252529	. Upper Saw Guide Mack (5/8' to 3/4")	USE ONE	4	090-252537	. Upper Saw Guide Block	1
Ref.	090-252537	. Upper Saw Guide Block (1")	ONE	5	134-085026	. Washer	2
Ref.	090-115437	Lower Saw Guide Ass'y. (5/8" to 3/4)		6	091-982421	. Screw, Soc. Hd. Cap 1/4-20NC x 1..	2
Ref.	090-115429	Lower Saw Guide Assy. (1")		7	090-183377	. Guide Guard	1
9	091-982421	. Screw, Sac. Hd. Cap 1/4.-20NC x 1 (5/8" to 3/4")	2	8	090-172180	. Bearing Cap	1
	091-982447	Screw, Sac. Hd. Cap 1/4-20NC x 1-1/4" (1")	2	9	090-115411	. Retaining Ring	1
10	090-115403	. Bearing Cap	1	10	090-115296	. Bearing	2
11	090-115411	. Retaining Ring	1	Ref.	090-177320	Lower Saw Guide Block (1")	
12	090-115296	. Bearing	2	11	090-252578	. Lower Saw Guide Block	1
13	134-085026	. Washer	2	12	091-982447	. Screw, Soc. Hd. Cap 1/4-20NC x 1-1/4	2
14	090-252586	. Lower Saw Guide block (5/8" to 3/4")	USE ONE	13	134-085026	. Washer	2
	090-252578	. Lower Saw Guide Block (1")	ONE	14	090-172180	. Bearing Cap	1
HEAVY DUTY GUIDES (CARBIDE BACKUP)							
Ref.	091-199182	Upper Saw Guide Ass'y. (1/16" to 1/2")		15	090-115411	. Retaining Ring	1
1	090-380767	. Upper Saw Guide Block	1	16	090-115296	. Bearing	2
2	091-982389	. Screw, Soc. Hd. Cap 1/4-20NC x 5/8	2	Ref.	093-048437	. 1 Inch Upper Saw Guide Stack Sub-Assembly	
3	134-085026	. Washer	2	1	091-212100	. Back-Up Insert	1
8	090-172180	. Bearing Cap	1	2	094-064300	. Upper Saw Guide Block	1
9	090-115411	. Retaining Ring	1	3	091-982447	. Scr. Soc. Hd. Cap 1/4-20NC x 1-1/4	2
10	090-115296	. Bearing	2	4	134-085026	. Washer	2
Ref.	091-190017	Lower Saw Guide Ass'y. (1/16" to 1/2")		5	091-102040	. Pivot Bolt	1
11	090-377383	. Lower Saw Guide Block	1	Ref.	093-048445	. 1 Inch Lower Saw Guide Block Sub Assembly	
12	091-982389	. Screw, Soc. Hd. Cap 1/4-20NC x 5/8	2	6	091-212100	. Back-Up Insert	1
13	134-085026	. Washer	2	7	091-102040	. Pivot Bolt	1
14	090-172180	. Bearing Cap	1	8	091-982447	. Scr. Soc. Hd. Cap 1/4-20NC x 1-1/4	2
				9	134-085026	. Washer	2
				10	094-067683	. Lower Saw Guide Block	1

****NOTE:** If Your Machine Was Equipped With Two Coolant Lines to the Upper Saw Guide, Order Additional Parts 091-094524 Swivel Joint, Qty. 1, 090-160011 Barbed Insert Qty. 2 and Delete 091-081166 90°- Barbed Insert, Qty. 1.

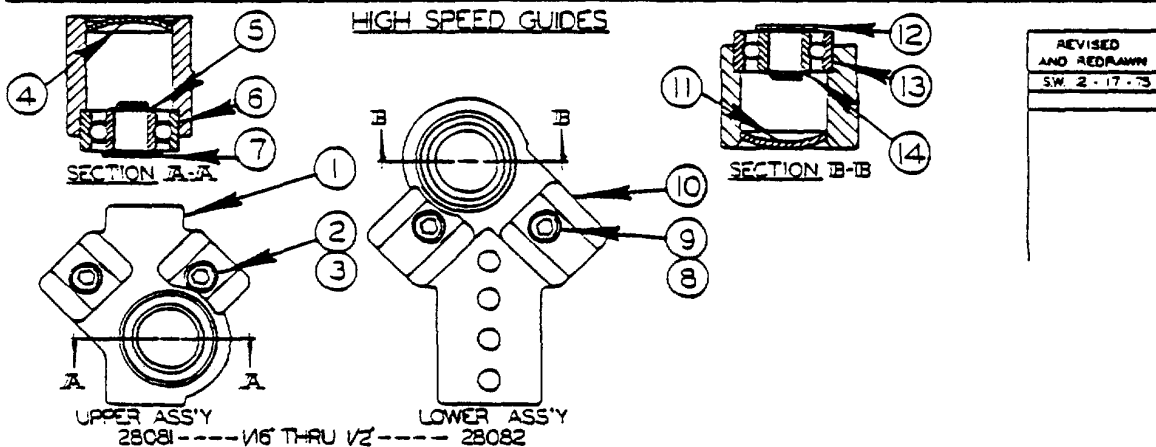
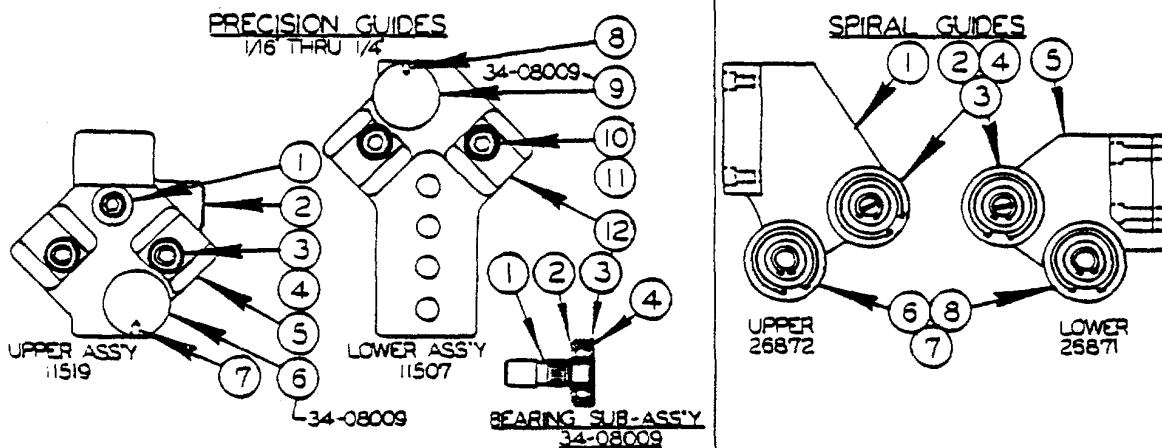

REVISED AND REDRAWN SW 2-17-73

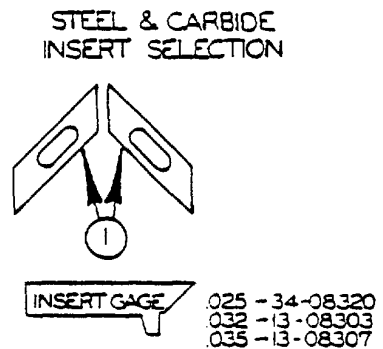
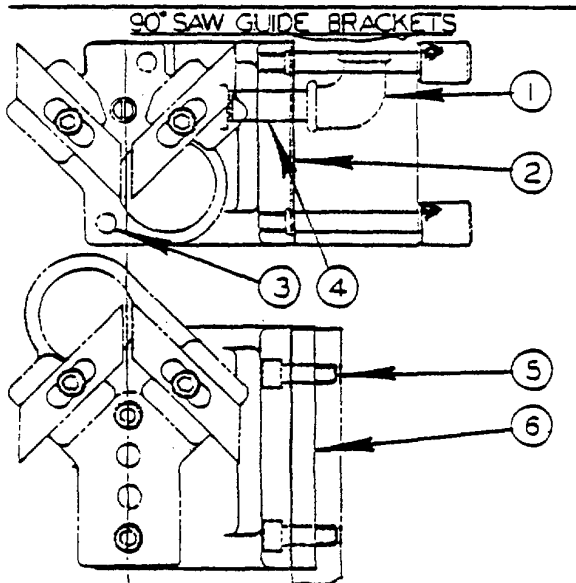

* 44804
ACCESSORY

SAW GUIDE SELECTION
* 121230

CODE NO. C-7-20
CM-7-29

#121230
SAW GUIDE SELECTION

INDEX NO.	CATALOG NO.	DESCRIPTION	UNITS PER ASS'Y
PRECISION GUIDES			
Ref.	090-115197	Upper Saw Guide Assembly, (1/16" to 1/4")	
1	091-984450	. Screw, Soc. Set 5/16-24 NF x 1/2.....	1
2	091-203695	. Soc. Hd. Pipe Plug.....	1
3	091-982389	. Screw, Soc. Hd. Cap 1/4-20NC x 5/8.....	2
4	134-085026	. Washer	2
5	090-252495	. Upper Saw Guide Block.....	1
6	134-080092	. Bearing Sub-Assembly (See Detail).....	1
7	091-985010	. Screw, Soc. Set #8-32 NC x 1/4".....	1
Ref.	090-115072	Lower Saw Guide Assembly (1/16" to 1/4")¶	
8	091-985010	. Screw, Soc. Set #8-32 NC x 1/4.....	1
9	134-080092	. Bearing Sub-Assembly (See Detail)	1
10	091-982389	. Screw, Soc. Hd. Cap 1/4-20NC x 5/8.....	2
11	134-085026	. Washer	2
12	090-252479	. Lower, Saw Guide Block	1
Ref.	134-080092	Bearing Sub-Assembly	
1	134-084185	. Shaft	1
2	134-090439	. Bearing	1
3	134-083096	. Roller Seal	1
4	134-083120	. Washer	1
SPIRAL GUIDES			
1	090-268723	Spiral Saw Guide Assembly (Upper)	
2	135-069532	. Eccentric Guide	1
3	NA Alone	. Tire Only	1
4	NA Alone	. Rim Only	1
5	090-268715	Spiral Saw Guide Assembly (Lower)	
6	135-069524	. Plain Guide	1
7	NA Alone	. Tire Only	1
8	NA Alone	. Rim Only	1
HIGH SPED GUIDES			
Ref.	090-280819	Upper Saw Guide Assembly (1/16" to 1/2")	
1	090-279811	Upper Saw Guide Block.....	1
2	091-982389	. Screw, Soc. Hd. Cap 1/4-20NC x 5/8.....	2
3	134-085026	. Washer	2
4	091-37339	. Plug.....	1
5	090-115411	. Retaining Ring	1
6	135-022804	. Bearing	1
7	090-184151	. Bearing Cap.....	1
Ref.	090-282827	Lower Saw Guide Assembly (1/16" to 1/2")	
8	091-982389	. Screw, Soc. Hd. Cap 1/4-20NC x 5/8.....	2
9	134-085026	. Washer	2
10	090-279837	. Lower Saw Guide Bock	1
11	091-373399	. Plug	1
12	090-184151	. Bearing Cap.....	1
13	135-022804	. Ball Bearing	1
14	090-115411	Retaining Ring	1
90° SAW GUIDE BRACKETS			
Ref.	090-448044	90° Saw Guide Assembly	
1	135-036473	. 90 Elbow	1
2	090-275975	. Upper Angle Block	1
3	091-982421	. Screw, Soc. Hd. Cap 1/4-20NC x 1	2
4	090-116583	. Nipple	1
5	091-982397	. Screw, Soc. Hd. Cap 1/4-20NC x 3/4	2
6	090-275966	. Lower Angle Block	1
	090-292616	. Center Plate 24 x 24 Table (Nor Shown).....	USE
	093-021780	. Center Plate 30 x 30 Table (Not Shown).....	ONE
STEEL AND CARBIDE INSERT SELECTION			
Ref.	090-044991	Steel Insert * Req'd	Ref.
	090-044983	1/16"	090-161688
	090-044975	3/32"	090-161704
	090-044967	1/8"	090-132911
	090-044959	3/16"	091-058941
	090-039603	1/4"	090-132929
	090-039595	3/8"	090-089822
	090-039587	1/2"	
	090-039579	5/8"	
	090-039561	3/4"	
		1"	
			Carbide Insert (4 Req'd)
			1/4"
			3/8"
			1/2"
			5/8"
			3/4"
			1"

TYPE I
ROLLER & SPINDLE ASSEMBLY

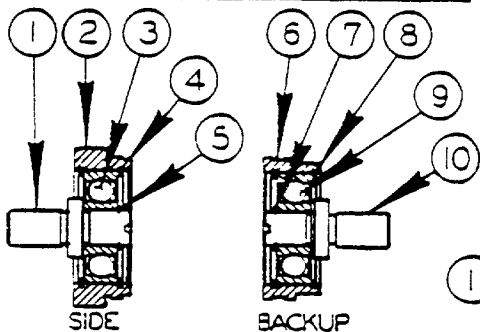

TYPE IA
ROLLER SAW GUIDES W/ROLLERS

NEW ORG.
SCL 10-24-73
REVISIONS

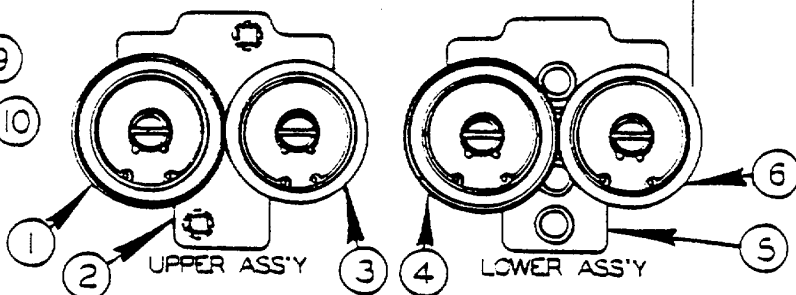

TYPE II
ROLLER & SPINDLE ASSEMBLY

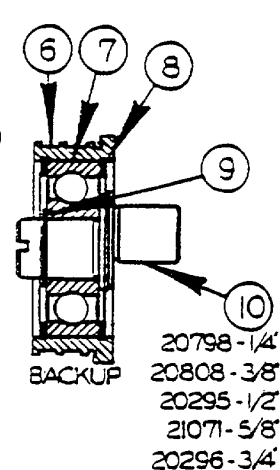
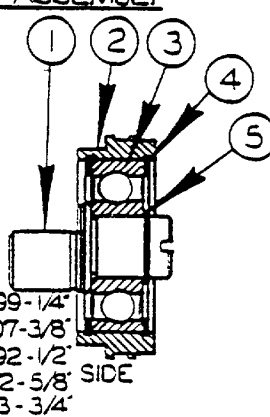
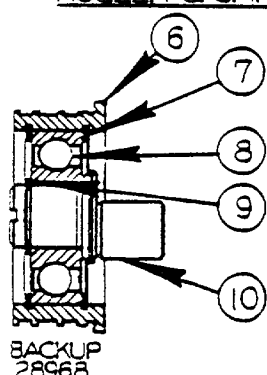
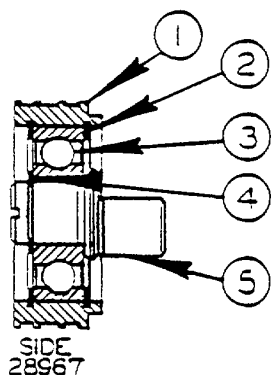

NOTE: ALSO USED FOR 1/4, 1/2, 3/4 BANDS WITH FLANGED WHEELS.

ROLLER GUIDE BLOCK ASSEMBLY

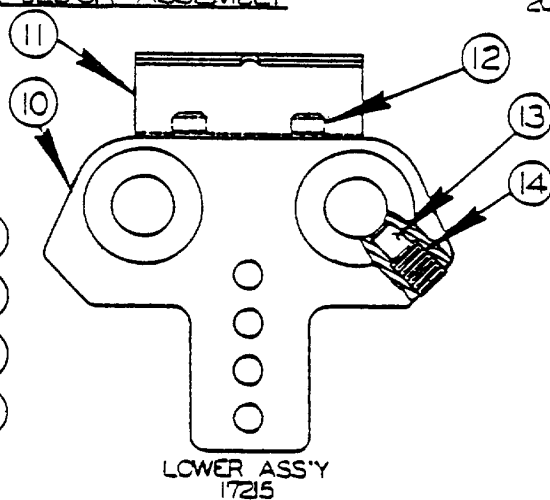
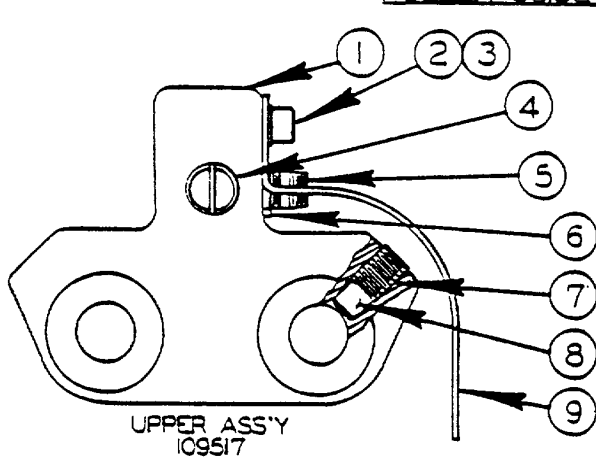

121230
SAW GUIDE SELECTION

SAW GUIDE SELECTION

INDEX NO.	CATALOG NO.	DESCRIPTION	UNITS PER ASS'Y	INDEX NO.	CATALOG NO.	DESCRIPTION	UNITS PER ASS'Y
TYPE I - ROLLER AND SPINDLE ASSEMBLY							
REF.	090-289844	Roller Sub-Assembly 1/4" Side		6	090-289687	Backup Roller Guide Assembly	
REF.	090-289802	Roller Sub-Assembly 3/8" Side		7	091-007583	. Guide Roller 1"	1
REF.	090-289745	Roller Sub-Assembly 1/2" Side		8	090-013038	. Retaining Ring	2
1	090-182965	. Bearing Shaft	1	9	090-017799	. Bearing	1
2	090-289851	. Roller 1/4"	Use	10	090-015686	. Retaining Ring	1
	090-289810	. Roller 3/8"			090-135302	. Spindle	1
	090-289752	. Roller 1/2"	One	Ref.	090-207994	Guide Roller Ass'y 1/4" Side	
3	090-415296	. Bearing (N.D. Z99500XRIE)	1	Ref.	090-208075	Guide Roller Ass'y 3/8" Side	
	091-000463	. Internal Ring	2	Ref.	090-202920	Guide Roller Ass'y 1/2" Side	
5	090-115411	. Snap Ring	1	Ref.	090-210725	Guide Roller Ass'y 5/8" Side	
REF.	090-289828	Flanged Roller Sub-Assembly 1/4" Backup		Ref.	090-202938	Guide Roller Ass'y 3/4" Side	
				1	090-135302	. Spindle	1
REF.	090-289786	Flanged Roller Sub-Assembly 3/8" Backup		2	090-135310	. Guide Roller 1/4"	Use
					090-135401	. Guide Roller 3/8"	
REF.	090-289760	Flanged Roller Sub-Assembly 1/2" Backup			090-135336	. Guide Roller 1/2"	
					090-135427	. Guide Roller 5/8"	
6	090-289836	. Flanged Roller 1/4"	Use		090-135351	. Guide Roller 3/4"	One
	090-289794	. Flanged Roller 3/8"		3	090-147799	. Bearing	1
	090-289773	. Flanged Roller 1/2"	One	4	090-013038	. Retaining Ring	2
7	090-115411	. Snap Ring	1	5	090-015686	. Retaining Ring	1
	091-000463	. Internal Ring	2	Ref.	090-207986	Backup Roller Guide Ass'y 1/4"	
9	090-115296	. Bearing (N.D. Z99500XRIE)	1	Ref.	090-208083	Backup Roller Guide Ass'y 3/8"	
10	090-182965	. Bearing Shaft	1	Ref.	090-202953	Backup Roller Guide Ass'y 1/2"	
TYPE IA - ROLLER SAW GUIDES WITH ROLLERS							
REF.	090-292566	Upper Roller Saw Guide Assembly 1/4"		Ref.	090-210717	Backup Roller Guide Ass'y 5/8"	
REF.	090-292582	Upper Roller Saw Guide Assembly 3/8"		Ref.	090-202961	Backup Roller Guide Ass'y 3/4"	
REF.	090-295064	Upper Roller Saw Guide Assembly 1/2"		6	090-135328	Backup Roller 1/4".....	Use
1	Ref.	Select flanged backup roller sub-ass'y from type 1 detail and parts list.			090-435419	. Backup Roller 3/8"	
					090-135344	. Backup Roller 1/2"	
2	090-239604	. Upper Saw Guide Block.....	1		090-135435	. Backup Roller 5/8"	
3	Ref.	Select side roller sub-ass'y from type 1 detail and part list.		7	090-135369	. Backup Roller 3/4"	One
	091-982397	. Scr., Soc. Hd. Cap 1/4-20NC x 3/4 (Not Shown)	2	8	090-017799	. Bearing	1
	091-993212	. Washer, Lock 1/4 Std. (Not Shown)	2	9	090-013038	. Retaining Ring	2
REF.	090-29257A	Lower Roller Saw Guide Ass'y 1/4"		10	090-015686	. Retaining Ring	1
REF.	090-292590	Lower Roller Saw Guide Ass'y 3/8"			090-135302	. Spindle	1
REF.	090-295056	Lower Roller Saw Guide Ass'y 1/2"		Ref.	091-095174	Roller Guide Block Assembly	
4	Ref.	Select flanged backup roller sub-ass'y from type 1 detail and parts list.		1	091-095174	Upper Guide Sub-Assembly	
				2	090-335175	. Upper Guide Block	1
5	090-289612	. Lower Saw Guide Block	1		091-982363	. Scr., Soc. Hd. Cap 1/4 20NC x 1/2	
6	Ref.	Select side roller sub-ass'y from type 1 detail and parts list.		3	091-993212	. Washer, Lock 1/4 Std	1
	091-982397	. Scr., Soc. Hd. Cap 1/4-20NC x 3/4 (Not Shown)	2	4	090-335092	. Coolant Nozzle.....	1
	091-993212	. Washer, Lock 1/4 Std	2	5	114-145287	. Close Nipple	1
TYPE II - ROLLER AND SPINDLE ASSEMBLY							
REF.	090-289679	Side Roller Guide Assembly		6	107-0151045	. Hex. Pipe Nipple	1
1	091-007583	. Guide Roller 1".....	1	7	091-984484	. Scr., Soc. Hd. Set 3/8-16 NC x 3/8	2
2	090-013038	. Retaining Ring	2	8	090-017419	. Plug	2
3	090-017799	. Bearing	1	9	090-326363	. Coolant Guard	1
4	090-315686	. Retaining Ring	1	Ref.	090-172156	. Cloth Bag (Not Shown)	1
5	090-135302	. Spindle	1	10	090-277435	Lower Guide Sub-Assembly	
				11	090-021403	. Lower Guide Block	1
				12	091-982355	. Chip Deflector	1
				13	090-017A19	. Scr., Soc. Hd. Cap 1/4-20NC x 3/8	2
				14	091-984492	. Plug	2
						. Scr., Soc. Hd. Set 3/8-16 NC x 1/2	2

REVISED
AND
REDRAWN
SCL 12-10-74

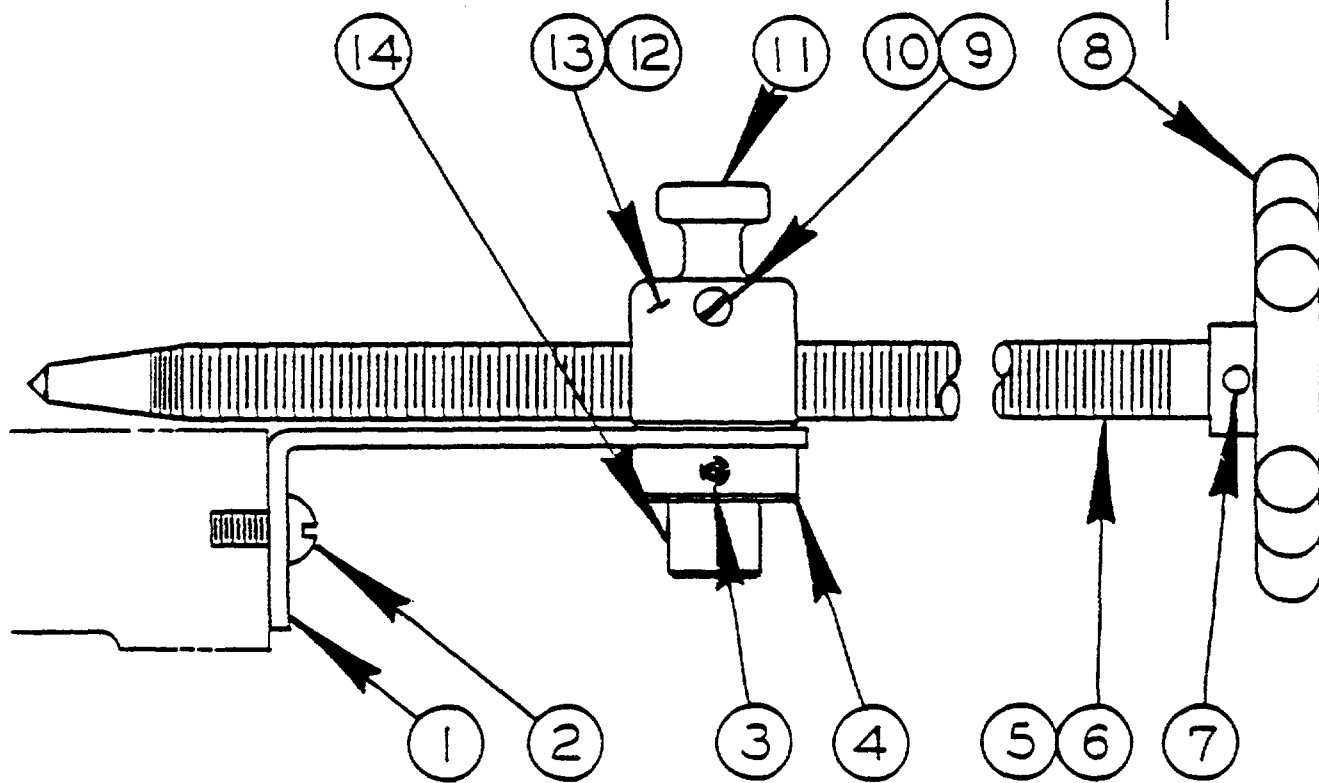

SCREW FEED ASSEMBLY

C-10-29 CM-10-17

SCREW FEED ASSEMBLY

INDEX NO.	CATALOG NO.	DESCRIPTION	UNITS PER ASS'Y
REF.	135-062123	Screw Feed Assembly (1612, 1612-0, 1612-1, 2013, 2013-0, 2013-1, 2013-10, 2012-1A, 2012-1AT, 2612-1 3612, 3613-1)	
REF.	090-454679	Screw Feed Assembly (1613-2, 2613-2, 3613-2, 6013-2)	
1	135-062115	. Feed Screw Bracket	1
2	091-988956	. Screw, Rd. Hd. Mach. 1/4-20 NC x 1/2	2
3	091-984104	. Screw, Soc. Set #10-24 NC x 1/4	1
4	111-284188	. Collar	1
5	111-030078	. Screw Feed Handle & Screw Sub-Assembly	1
6	111-034013	.. Screw Feed Screw.....	1
7	090-042557	.. Roll Pin	1
8	134-031061	.. Screw Feed Handle	1
*9	135-052249	. Screw Feed Swivel Sub-Assembly	1
10	091-988386	.. Screw, Rd. Hd. Mach. #6-32 NC x 1/4.....	1
11	105-034029	.. Screw Feed Key	1
12	105-035026	.. Steel Ball.....	2
13	105-035018	.. Detent Spring	1
14	105-034011	.. Screw Feed Swivel	1

NOTE: Starred Items Used Only On Assembly #090-454679.

REVISED AND REDRAWN
SCL 10-30-74
SW 3-3-77
CAK 5-11-78

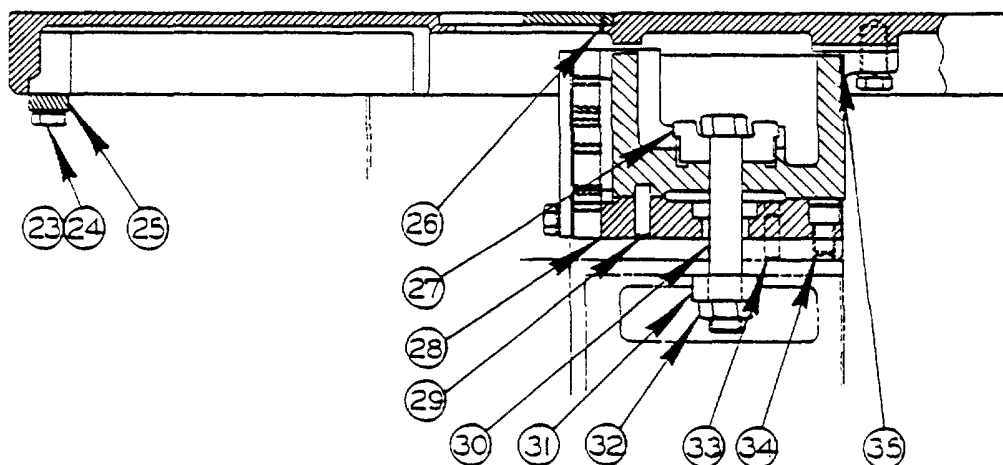
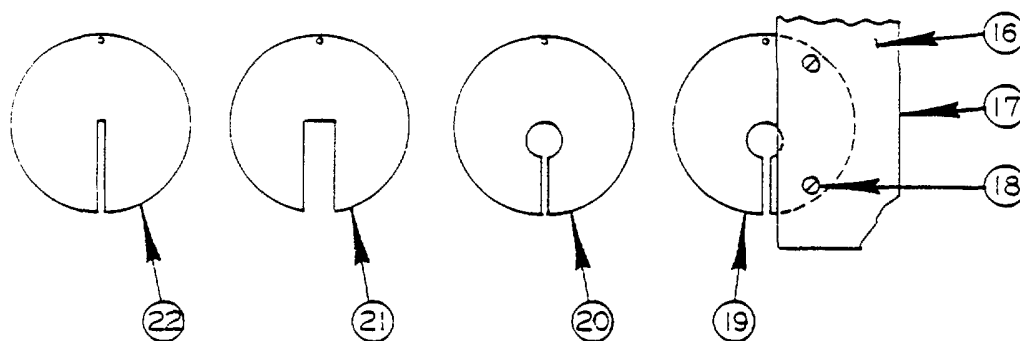
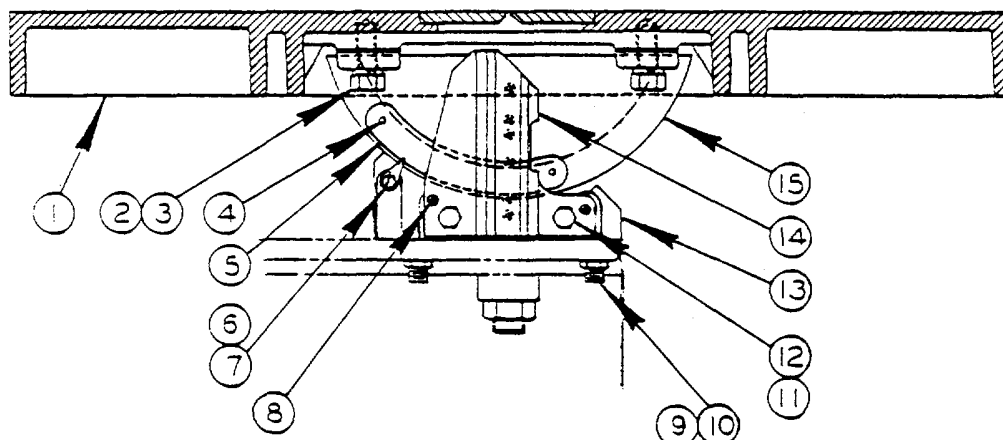

MODEL	FIRST MACH	LAST MACH
16M	134-58101	134-60590
30M	135-58101	135-59218
1612-U	146-59101	146-682364
3012-U	147-59101	147-681104
1611-U	270-68101	270-68156
3612-U	271-68101	271-68131
2612-1	172-60101	172-68229
1612-0	209-62101	209-681820
3613-0	244-66101	244-68192
1612-1	148-59101	148-731539
3613-1	149-60134	149-73706
1612-0	277-68101	277-751728
3613-0	278-68101	278-77825
2612-1	285-68101	285-76200
1612	287-68101	287-76450
3612	291-68101	291-77235
3612-1	380-77101	
3613-0	381-77101	
3612-2	398-78101	
3613-20	399-78101	

TABLE AND TRUNNION ASSEMBLY

TABLE AND TRUNNION ASSEMBLY

INDEX NO.	CATALOG NO.	DESCRIPTION	UNITS PER ASS'Y
REF.	090-524356	Table And Trunnion Assembly (16M & 30M, 1611-U, 3012-U, 1612-U, 3612-U, 1612-.0, 3613-0, 1612, 3612, 3612-1, 3613-10, 3612-2, 3613-20)	
REF.	090-549353	Table And Trunnion Assembly (1612-1)	
REF.	090-553066	Table And Trunnion Assembly (2612-1, 3613-1)	
REF.	090-598624	Table And Trunnion Assembly (2612-1, 3613-1)	
1	090-541855	. Table (24" x 24" Specify Size).....	USE
	090-553033	. Table (26" x 26" Specify Size).....	
	090-598269	. Table (30" x 30" Specify Size)	ONE
2	091-980656	. Screw, Hex. Hd. Cap 1/2-13 NC x 1	4
3	091-993774	. Washer, Lock 1/2" Shakeproof Ext	4
4	091-994012	. Screw, Rd. Hd. Drive PK #6 x 3/8 Type "U".....	2
5	090-038613	. Escutcheon	1
6	134-033158	. Pointer	1
7	091-988378	. Screw, Rd. Hd. Mach. #6-32 NC x 3/16	1
8	135-005163	. Dowel Pin	2
9	091-985788	. Screw, Soc. Set 3/8-16 NC x 3/4 Flat Point (090-524356 Only)	5
10	091-991273	. Nut, Jam 3/8-16 NF (090-524356 Only)	5
11	091-980458	. Screw, Hex. Hd. Cap 3/8-16 NC x 7/8 /090-524356 Only).....	2
	091-980474	. Screw, Hex. Hd. Cap 3/8-16 NC x 11/4 t090-549353, 090-598624 Only)	2
12	091-993329	. Washer, Lock 3/8 Std	A.R.
13	090-406497	. Cradle	1
14	090-242447	. Lower Post Block	1
15	090-406455	. Trunnion	1
*16	090-076456	. Small Parts Filing Assembly	1
*17	090-120460	.. Plate	1
*18	091-987487	.. Screw, Fiat Hd. Cap #10-24 NC x 3/8.....	2
*19	090-120452	.. Center Plate	1
*20	090-106279	. Center Plate (Used on Band Filing Assembly)	1
*21	090-105701	. Center Plate (Used on Band Polishing Assembly)	1
22	090-10A902	. Center Plate	1
23	091-980466	. Screw, Hex. Hd. Cap 3/8-16 NC x 1	2
24	091-992644	. Washer, Flat 3/8 Std	1
25	090-045998	. Clamp	1
26	090-042094	. Roll Pin	1
*27	090-394644	. Head	1
28	091-333203	. Shim (090-524356 Only)	A.R.
	091-333211	. Shim (090-524356 Only)	A.R.
29	114-004732	. Dowel Pin	2
30	091-981068	. Screw, Hex. Hd. Cap 3/4-16 NC x 5	USE
	091-981233	. Screw, Hex. Hd. Cap 3/4-16 NC x4 3/4	ONE
31	090-105016	. Spacer	1
32	091-991414	. Nut, Hex. 3/4-16 NF	1
33	134-134071	. Dowel Pin	2
34	091-982918	. Screw, Soc. Hd. Ca 1/2-13 NC x 3/4.....	4
35	091-333104	. Shim (090-598624, 090-524356 Only)	A.R.
	091-333112	. Shim (090-598624, 090-524356 Only)	A.R.
	091-333120	. Shim (090-598624, 090-524356 Only)	A.R.
	091-333138	. Shim (090-598624, 090-524356 Only)	A.R.
	135-009934	. Shim (090-549353, 090-553066 Only)	A.R.
	090-108531	. Wrench(Not Shown) (090-524356 Only)	1
	091-333146	. Shim (090-598624 Only)	A.R.

***Note: Items #16 thru #21 Are Not Port of Assemblies 090-524356, 090-549353, 090-553066, 090-598624.**

****Note: Before Ser. #287-70259 on 1612, Before Ser. #277-70778 on 1612-0, Before Ser. #148-701464 on 1612-1, And Before Ser. 4278-70253 on 3613-0, 090-394644 Head Was 090-107566.**

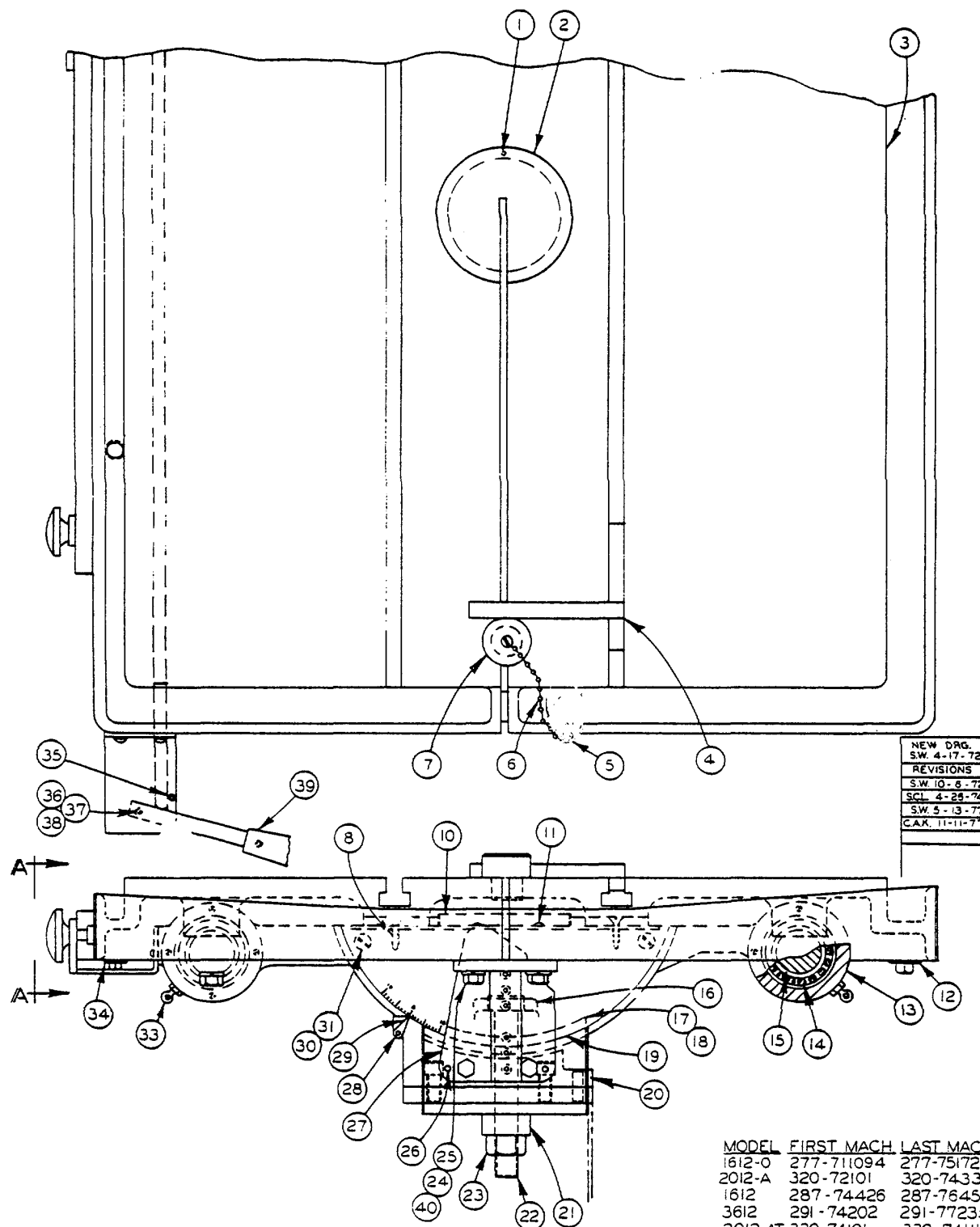

SLIDING TABLE ASS'Y.
AIR FEED

C-3-78

**SLIDING TABLE ASSEMBLY
(AIR FEED)**

INDEX NO.	CATALOG NO.	DESCRIPTION	UNITS PER ASS'Y
Ref.	501532	Sliding Table Assembly (1612-0, 1612, 3612, 2614-1, 3612-1, 3613-10)	
Ref.	503826	Sliding Table Assembly (2012-A, 2012-1A, 2012-AT, 2012-1AT, 2012-2A)	
1	090-042094	. Roll Pin	1
2	090-104902	. Center Plate	1
3	095-013801	. Table	1
4	091-253617	. Square Weldment	1
5	091-988519	. Screw, Rd. Hd. Mach. #8-32 NC x 1/4	2
6	091-295907	. Chain	1
7	091-253930	. Plug	1
8	091-990192	. Screw, Truss Hd. Mach. 1/4-20 NC x 3/8	6
10	095-030458	. Pan	1
11	091-988675	. Screw, Rd. Hd. Mach. #10-24 NC x 3/8	16
12	135-065803	. Pipe Plug	1
13	090-507914	. Trunnion	1
14	090-036476	. Ball Bushing	4
15	090-051806	. Spacer	2
16	090-394644	. Head	1
17	090-410937	. Chip Guard Assembly (#501532)	1
18	090-450800	. Chip Cover Assembly (#501532)	1
19	090-216219	. Trunnion Plate	1
20	090-409038	. Cradle	1
21	090-105016	. Spacer	1
22	091-981068	. Screw, Hex. Hd. Cap 3/4-16 NF x 5	1
23	091-991414	. Nut, Hex. 3/4-16 NF	1
24	091-980474	. Screw, Hex. Hd. Cap 3/8-16 NC x 1-1/4	4
25	091-993329	. Washer, Lock 3/8 Std.	10
26	135-003283	. Dowel Pin	2
27	090-242413	. Keeper Block	1
28	091-988386	. Screw, Rd. Hd. Mach. 06-32 NC x 1/4"	1
29	134-033158	. Pointer	1
30	091-988931	. Screw, Rd. Hd. Mach. 1/4-20 NC x 3/8 (#501532)	2
	091-988220	. Screw, Pan Hd. Mach. 1/4-20 NC x 3/8 (#503826)	2
31	091-993568	. Washer, Lock 1/4 Shakeproof Int	8
33	090-087909	. Lube Fitting 90°	2
34	106-335185	. Pipe Plug	1
35	090-042441	. Roll Pin	1
36	091-046326	. Belleville Washer	6
37	091-982520	. Screw, Soc. Hd. Cap 1/4-28 NF x 1-1/4	1
38	091-156604	. Locknut	1
39	091-310110	. Handle Sub-Assembly	1
40	091-992644	. Washer, Flat 3/8 Std. S.A.E.	2
Following Items Not Shown:			
	091-319483	. Guard Assembly (#503826)	1
	111-055091	. Pipe Plug (#503826)	1
	090-285271	. Handle Assembly	1
	091-294470	. Screw Assembly	1

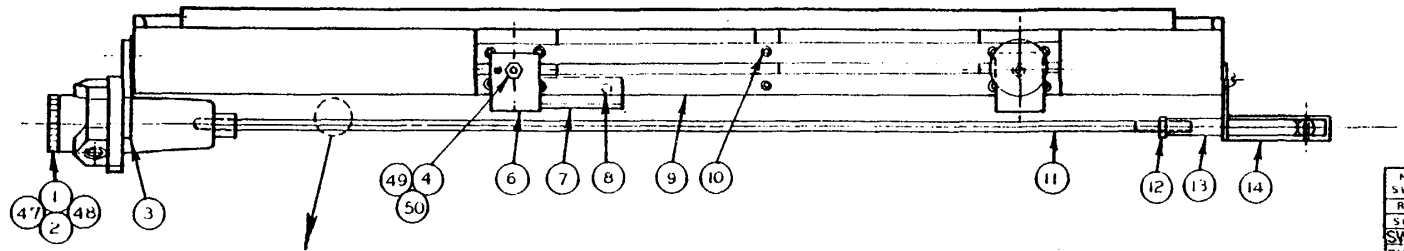

VIEW A - A

NEW DRG
SW 4-17-72
REVISIONS
SC 1 4-25-74
SW 5-17-76
SW 5-13-77
CK 11-11-77

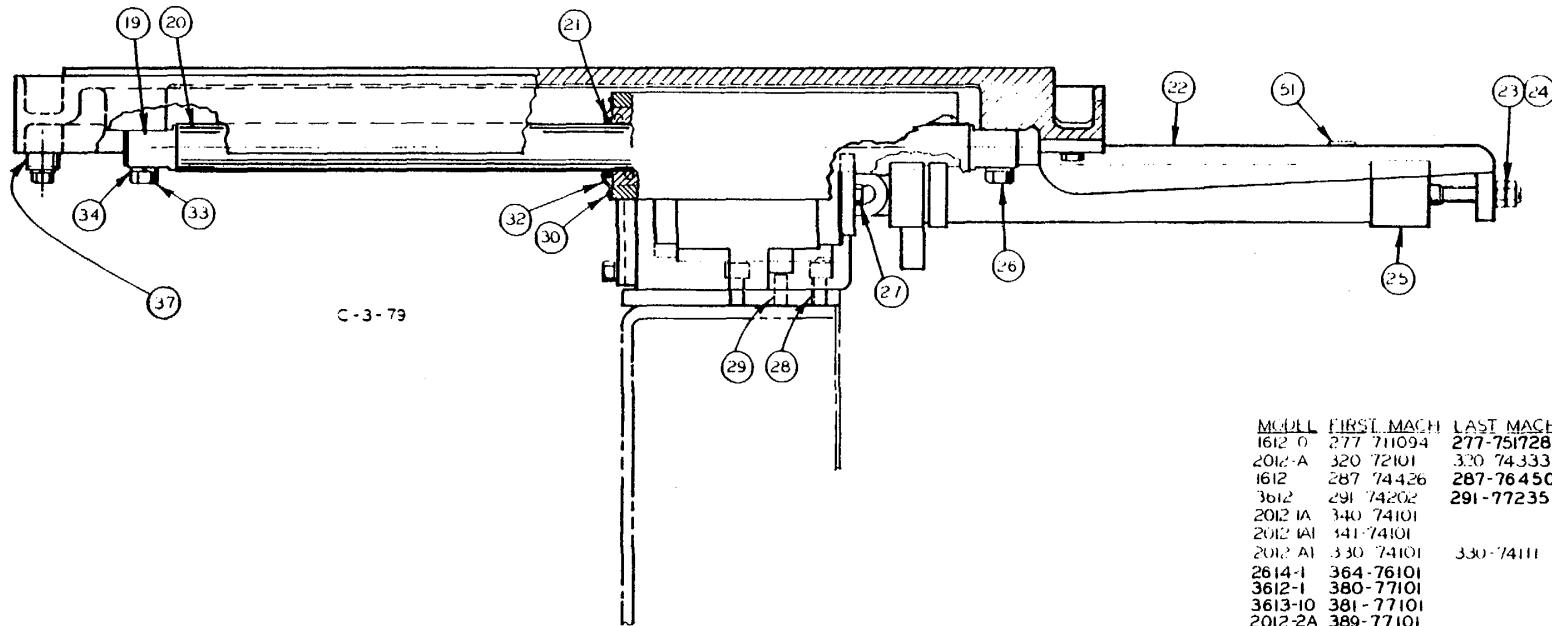
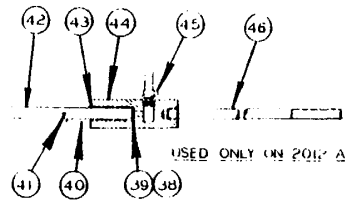

C-3-79

MODEL	FIRST MACH	LAST MACH
1612-0	277-711094	277-751728
2012-A	320-72101	330-74333
1612	287-74426	287-76450
3612	291-74202	291-77235
2012 IA	340-74101	
2012 AI	341-74101	
2012 A1	330-74101	330-74111
2614-1	364-76101	
3612-1	380-77101	
3613-10	381-77101	
2012-2A	389-77101	

SLIDING TABLE ASS Y
AIR FEED

SLIDING TABLE ASSEMBLY(AIR FEED)

INDEX	CATALOG	DESCRIPTION	UNITS PER
NO.	NO.		ASS'Y
Ref.	501532	Sliding Table Assembly (1612-0, 1612, 3612, 2614-1, 3612-1, 3613-10)	
Ref.	503826	Sliding Table Assembly (2012-A, 2012-1A, 2012-AT, 2012-1AT, 2012-2A)	
1	091-256743	. Regulating Valve	1
2	091-987107	. Screw, Fil. Hd. Mach. #12-24 NC x 3/4	2
3	091-253864	. Mounting Plate (#503826)	1
4	090-093923	. T-Bolt	2
5	090-149097	. Knob	2
6	090-095043	. Dog	2
7	090-095035	. Stop	1
8	091-988956	. Screw, Rd. Hd. Mach. 1/4-20 NC x 1/2	5
9	090-239674	. Slide Bar	2
10	091-982215	. Screw, Soc. Hd. Mach. #10-24 NC x 5/8	10
11	091-253872	. Actuator Rod	1
12	091-991273	. Nut, Hex. Jam 3/8-16 NC	1
13	091-253880	. Shaft	1
14	091-253898	. Bracket Weidment	1
15	090-042557	. Roll Pin	1
16	091-253922	. Shaft	1
17	091-181164	. Tapered Handle	1
18	090-042425	. Roll Pin	1
19	091-333104	. Shim	A.R.
	091-333112	. Shim	A.R.
	091-333120	. Shim	A.R.
	091-333138	. Shim	A.R.
20	090-216128	. Guide Rod	2
21	090-051772	. Scraper Ring	4
22	094-045465	. Cylinder Bracket	1
23	091-193649	. Grip Ring (#501532)	1
24	091-991349	. Nut, Hex. Jam 1/2-20 NC (#503826)	2
25	094-033206	. Table Cylinder Assembly (See Detail)	1
26	091-980441	. Screw, Hex. Hd. Cap 3/8-16 NC x 3/4	4
27	091-980276	. Screw, Hex. Hd. Cap 5/16-18 NC x 3/4	2
28	091-982918	. Screw, Soc. Hd. Cap 1/2-13 NC x 3/4	4
29	134-134071	. Dowel Pin (#501532)	2
	090-163510	. Dowel Pin (#503826)	2
30	091-993196	. Washer, Lock #10 Std	16
31	091-988659	. Screw, Rd. Hd. Mach. #10-24 NC x 1/4	2
32	090-051764	. Retainer	4
33	091-980698	. Screw, Hex. Hd. Cap 1/2-13 NC x 2	4
34	091-993279	. Washer, Lock 1/2 Std	4
35	091-980466	. Screw, Hex. Hd. Cap 3/8-16 NC x 1	2
36	091-992644	. Washer 3/8 Std	A.R.
37	090-045998	. Clamp	1
	093-013712	. Release Valve Assembly (2012-A Only)	1
38	091-282319	.. Seal Disc	1
39	134-015031	.. Adhesive	A.R.
40	090-017906	.. Spring	1
41	090-042151	.. Roll Pin	1
42	091-282152	.. Plunger	1
43	114-065535	.. Bearing	1
44	093-013720	.. Valve Body	1
45	090-160011	.. Barbed Insert	1
46	091-282160	.. Actuator Rod	1
47	091-980094	. Screw, Hex. Hd. Mach. 1/4-20 NC x 7/8	2
48	091-227488	. Pipe Plug	1
49	091-982181	. Screw, Soc. Hd. Cap #10-24 NC x 1/4	2
50	091-991224	. Nut, Hex. 5/16-18 NC	2
51	090-062910	. Plug Button	1

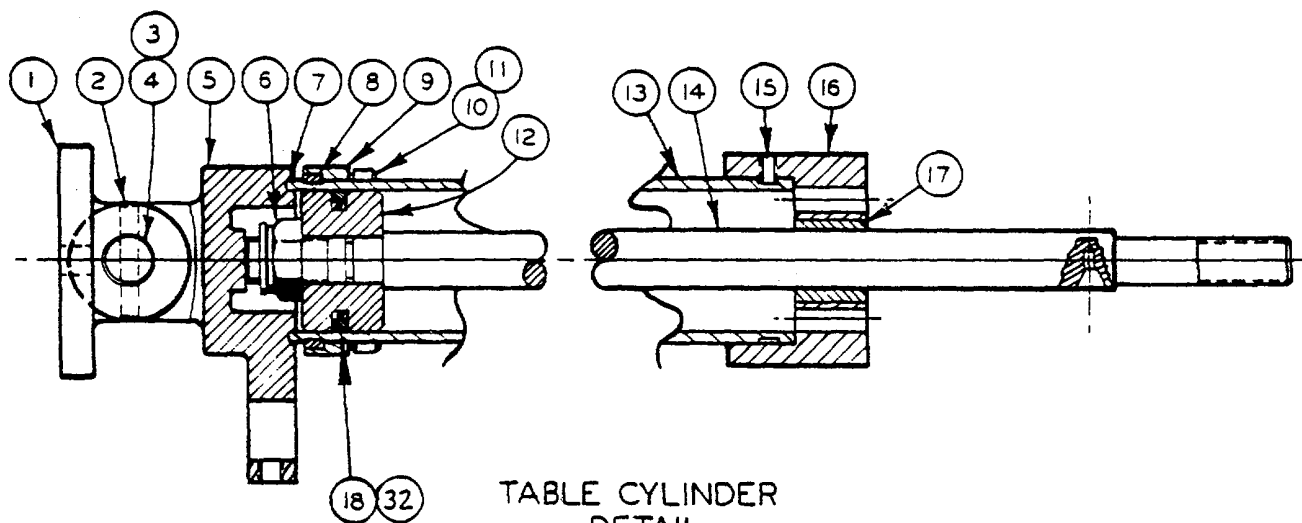
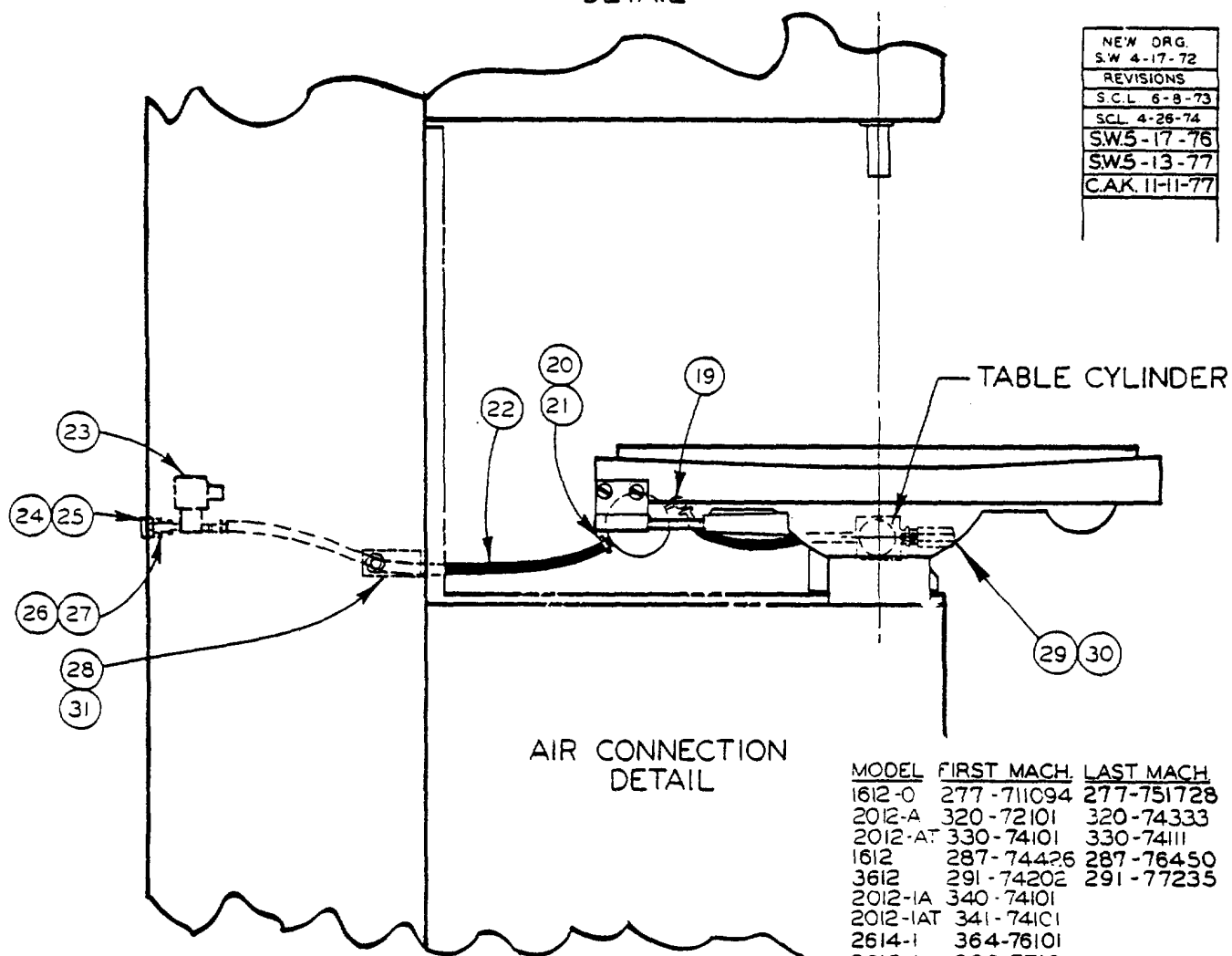

TABLE CYLINDER
DETAIL

NEW ORG.
S.W. 4-17-72
REVISIONS
S.C.L. 6-8-73
SCL 4-26-74
SW5-17-76
SW5-13-77
CAK. 11-11-77



AIR CONNECTION
DETAIL

AIR FEED
SLIDING TABLE ASS'Y.

MODEL	FIRST MACH.	LAST MACH.
1612-0	277-711094	277-751728
2012-A	320-72101	320-74333
2012-AT	330-74101	330-74111
1612	287-74426	287-76450
3612	291-74202	291-77235
2012-1A	340-74101	
2012-1AT	341-74101	
2614-1	364-76101	
3612-1	380-77101	
3613-10	381-77101	
2012-2A	389-77101	

C-3-80

CODE NO. C-3-80

SLIDING TABLE ASSEMBLY
 (AIR FEED)

INDEX NO.	CATALOG NO.	DESCRIPTION	UNITS PER ASS'Y
Ref.	501532	Sliding Table Assembly (1612-0, 1612, 3612, 2614-1, 3612-1, 3613-10)	
Ref.	503826	Sliding Table Assembly (2012-A, 2012-1A, 2012-AT, 2012-1AT, 2012-2A)	
Ref.	094-033206	. Table Cylinder Assembly	1
1	090-215948	.. Swivel	1
2	090-042615	.. Roll Pin	1
3	135-008910	.. Shim	2
4	090-051301	.. Swivel Pin	1
5	090-256553	.. Rear Cylinder Cap	1
6	090-127762	.. Locknut	1
7	135-004638	.. Cylinder Gasket	1
8	135-004661	.. Snap Ring	2
9	135-004653	.. Cylinder Collar	1
10	091-982421	.. Screw, Soc. Hd. Cap 1/4-20NC x 1	4
11	090-035593	.. Washer, Lock 1/4-Hi-Collar	4
12	091-256859	.. Piston	1
13	091-278218	.. Cylinder	1
14	093-023273	.. Piston Rod.....	1
15	091-154278	.. Screw, Soc. Set Self-Locking.....	3
16	093-004687	.. End Cap.....	1
17	090-051236	.. Bearing	1
18	091-277749	.. Seal Ring	1
19	117-135210	. 90° Street Elbow	1
20	091-044784	. Hose Clamp (#501532)	6
	135-068880	. Hose Clamp (#503826)	4
21	090-020041	. Barbed Insert	6
22	090-000035	. Hose 3/8 O.D. (#501532)	A.R.
	091-970962	. Hose 5/8 O.D. (#503826)	A.R.
* 23	091-194019	. Solenoid Valve 120V 60 Hz	Use
	091-194043	. Solenoid Valve 240V 60 Hz	
	091-194084	. Solenoid Valve 380V 60 Hz	
	091-194076	. Solenoid Valve 480V 60 Hz	One
* 24	091-256735	. Bulkhead Adapter	1
* 25	114-035074	. Close Nipple	2
* 26	090-038183	. Reducing Coupling	2
* 27	114-145287	. Close Nipple	3
* 28	091-281485	. Manifold	1
* 29	091-059964	. Reducer Bushing	1
* 30	093-034171	. Orifice	1
* 31	091-203695	. Pipe Plug	1
*	091-458836	. Oil Lubricator (Not Shown)	1
32	091-128066	.. "O"-Ring	1
	091-454991	. Escutcheon	1

*NOTE: Starred Items Used Only On Assembly #501532.

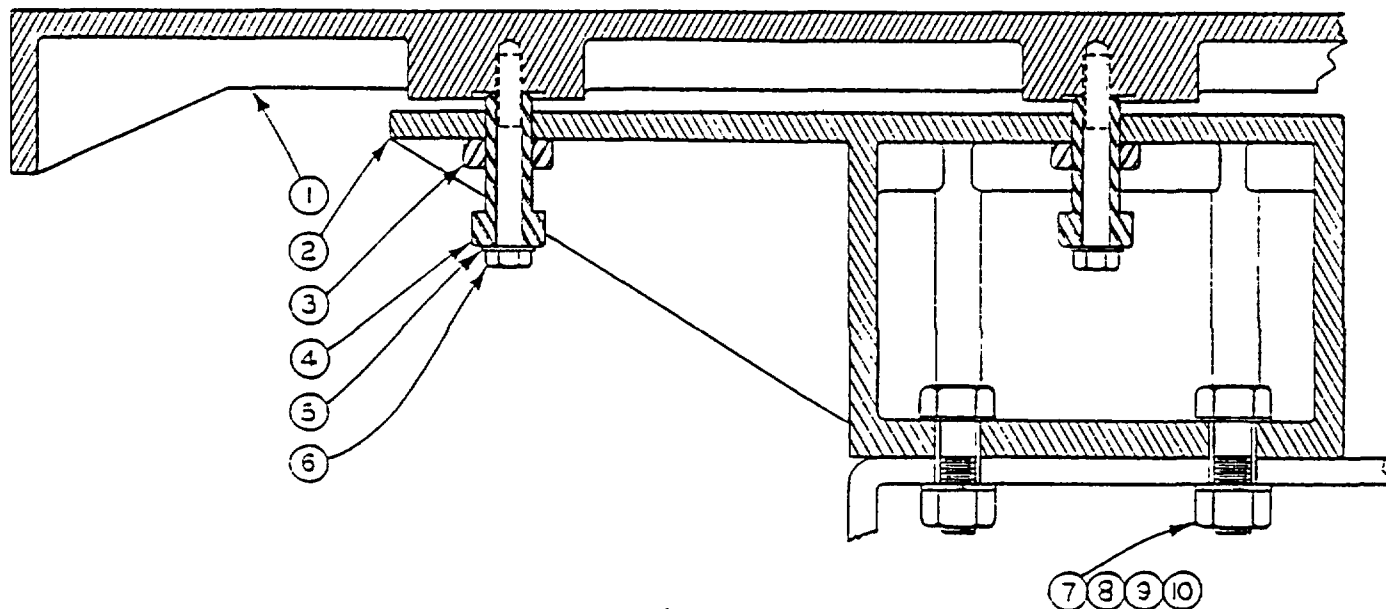

FITS ALL 36" MACHINES
 #50369
 SECONDARY TABLE MOUNTING ASSY
 C-3-38 CM-3-26

SECONDARY TABLE ASSEMBLY

INDEX NO.	CATALOG NO.	DESCRIPTION	UNITS PER ASS'Y
Ref.	50369	Secondary Table Assembly	
Ref.	48046	Secondary Table Assembly (3612-31)	
Ref.	503536	Secondary Table Assembly (3612-1H3)	
1	111-031068	. Secondary Table	1
2	090-208273	. Secondary Tool. Support (Use on Ass'y. 503691	USE
	090-480450	. Secondary Table Support (Use on Ass'y. 148046 & 503536)	ONE
3	091-991364	. Nut, Jam s 5/8-11 NC	4
4	111-034047	. Secondary Table Support Stud	4
5	091-995589	. Washer, Lock 3/8" Shakeproof Int	4
6	091-980532	. Screw, Hex. Hd. Cap 3/8-16NC x 2-3/4.....	4
7	091-980672	. Screw, Hex. Hd. Cap 1/2-13NC x 1-1/2.....	4
8	091-993048	. Washer, Wrought 1/2" Std.....	4
9	091-991315	. Nut, Hex. 1/2-13NC	4
10	091-993279	. Washer, Lack 1/2" Std.....	4
	090-086885	. Cover Plate Assembly (Not Shown) (Ass'y. #503536)	1

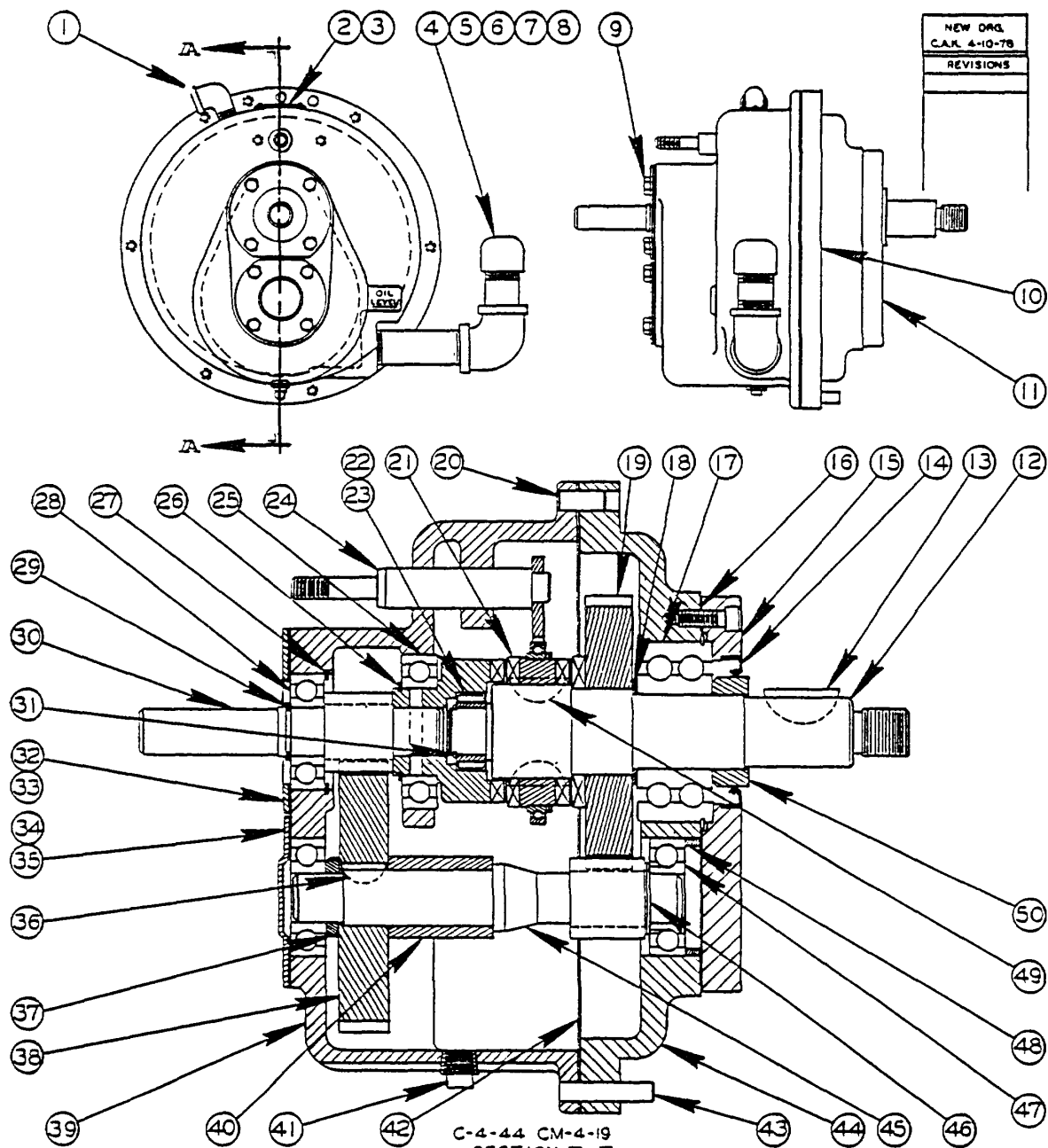

MODEL	FIRST MACH	LAST MACH
2012-2A	389-77101	
2013-20	377-77101	
2013-2	396-78101	
2012-2H	383-78101	
2012-2H3	397-78101	
3612-2	398-78101	
3613-20	399-78101	
3612-2H	400-78101	
3612-2H3	401-78101	

TRANSMISSION ASSEMBLY
C-4-44 CM-4-19

TRANSMISSION ASSEMBLY

INDEX NO.	CATALOG NO.	DESCRIPTION	UNITS PER ASS'Y
Ref.	095-068276	2-Speed Transmission Assembly	
1	117-135210	. 90° Street Elbow.....	1
2	091-601492	. Escutcheon	1
3	091-993964	. Drive Screw #2 x 3/16"	2
4	091-001875	. Nipple	1
5	105-046171	. 90° Elbow	1
6	090-059056	. Pipe Nipple	1
7	090-110693	. Pipe Cap	1
8	091-384453	. Oil (ASTM 315)	A.R.
9	091-980052	. Screw, Hex. Hd. Cap 1/4-20NC x 3/8	8
10	091-987701	. Screw, Flat Hd. Mach. 5/16-18NC x 1.....	4
11	091-982389	. Screw, Soc. Hd. Cap 1/4-20NC x 3/4	5
12	094-086378	. Output Shaft	1
13	105-046049	. Woodruff Key.....	1
14	091-475244	. Oil Seal	1
15	094-086410	. Bearing Cover Plate	1
16	093-073419	. Gasket	1
17	091-475236	. Ball Bearing	1
18	091-475228	. Spacer	1
19	106-044217	. Clutch Gear	1
20	135-004430	. Dowel Pin	1
21	091-114512	. Shifter Clutch Sub-Assembly	1
22	091-476200	. Needle Bearing.....	1
23	091-476218	. Inner Race	1
24	091-114496	. Shifter Fork Assembly	1
25	090-022732	. Ball Bearing	1
26	135-075380	. Retaining Ring.....	1
27	135-081891	. Retaining Ring	1
28	091-001222	. Bearing	1
29	135-086643	. Retaining Ring.....	1
30	093-073435	. Input Shaft Assembly	1
31	135-086882	. Retaining Ring.....	1
32	091-056887	. Cover Plate	1
33	091-056895	. Gasket	1
34	105-043038	. Counter Shaft Bering Cover	2
35	105-043095	. Gasket	2
36	105-046023	. Woodruff Key.....	1
37	091-032359	. Spacer	1
38	105-044242	. Gear	1
39	090-548710	. Transmission Case	1
40	091-027268	. Spacer	1
41	105-046122	. Square Hd. Pipe Plug.....	1
42	105-043111	. Gasket	1
43	090-131228	. Dowel Pin	1
44	095-068284	. Transmission Cover.....	1
45	090-292699	. Counter Shaft	1
46	091-057000	. Shim .005 Thk.	2
47	091-085571	. Bearing	2
48	091-476226	. Bearing Spacer	1
49	135-071926	. Woodruff Key.....	2
50	091-475210	. Seal Ring	1

REVISED AND REDRAWN
S.W. 10-3-74

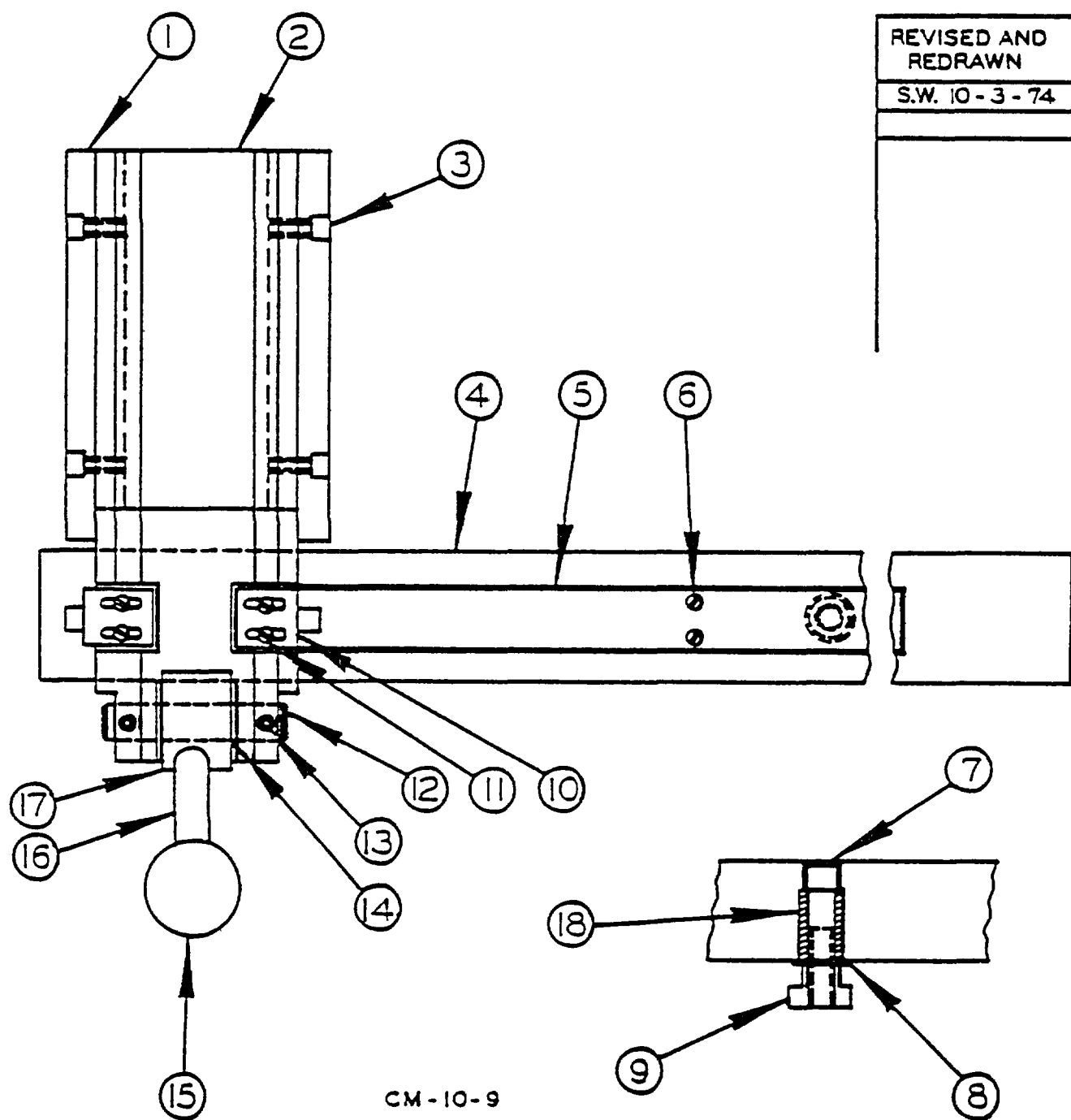

CM-10-9

UNIVERSAL CAL. WORK FIXTURE
(USE WITH T-SLOT TABLE ONLY)

FITS ALL CONTOUR-
MATIC MACHINES

CODE NO. CM-10-9

UNIVERSAL CALIBRATED WORK FIXTURE

INDEX NO.	CATALOG NO.	DESCRIPTION	UNITS PER ASS'Y
REF.	090-450842	Universal Calibrated Work Fixture (English) 26-3, 60-3, 2612-H, 2613-3, 2618-4, 6013-3, 6013-1-1H3	
REF.	090-450834	Universal Calibrated Work Fixture (English) 16-2, 36-3, 1612-H, 1612-3, 2012-A, 2012-AT, 2012-1AT, 3612-H, 3612-3, 3612-1H, 3612-1, 3613-10	
REF.	094-049079	Universal Calibrated Work Fixture (Metric) 2012-A, 2012-AT, 2012-1A, 2012-1AT, 3612-1H, 3612-1, 3613-10	
REF.	094-048170	Universal Calibrated Work Fixture (Metric) 2612-H	
1	090-183906	. Wear Strip	2
2	090-450859	. Head	1
3	091-982363	. Screw, Soc. Hd. Cap 1/4-20NC x 1/2	4
4	090-450875	. Bar (Used an Ass'y #094-048170 & 090-450842)	1
	090-A50867	. Bar (Used on Ass'y 0094-049079 & 090-450834)	1
5	090-450891	. Scale (Used on Ass'y #090-450842)	USE
	090-450883	. Scale (Used on Ass'y #090-450834)	
	090-475005	. Scale (Used on Ass'y #094-049079)	
	090-474990	. Scale (Used on Ass'y -#094-048170)	ONE
6	091-988337	. Screw, Rd. Hd. Mach. #5-40NC x 1/8	10
7	091-982819	. Screw, Soc. Hd. Cap 3/8-16NC x 11/2	USE
	091-982827	. Screw, Soc. Hd. Cap 3/8-16NC x 13/4	TWO
8	091-992644	. Washer, Flat 3/8 S.A.E	2
9	090-038555	. T-Nut	2
10	090-183922	. Pointer	2
11	091-990051	. Screw, Truss Hd. Mach. #6-32NC x 1/4 Plated.....	4
12	090-183914	. Pin	1
13	091-984179	. Screw, Soc. Set #10-32NF x 1/4	2
14	090-288929	. Can Assembly	1
15	134-135086	. Ball	1
16	090-025792	. Handle	1
17	091-007021	. Cam	1
18	091-011171	. Collar	1

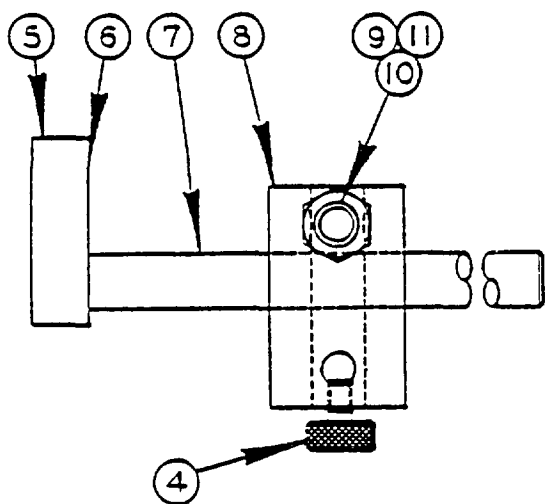

*20453
CUTOFF GAUGE ASSEMBLY

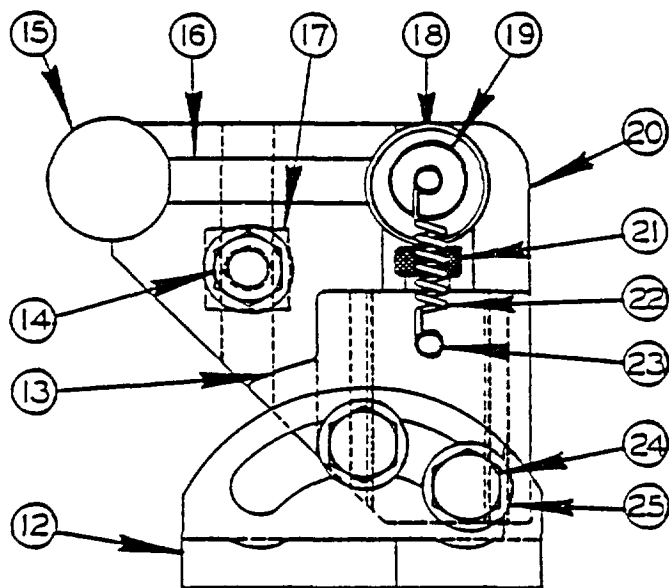

*40364
FRONT VISE ASSEMBLY

REVISED AND
REDRAWN
SC- 11-21-74

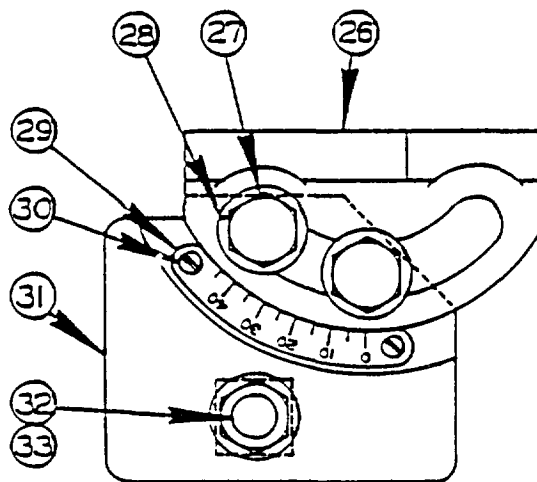
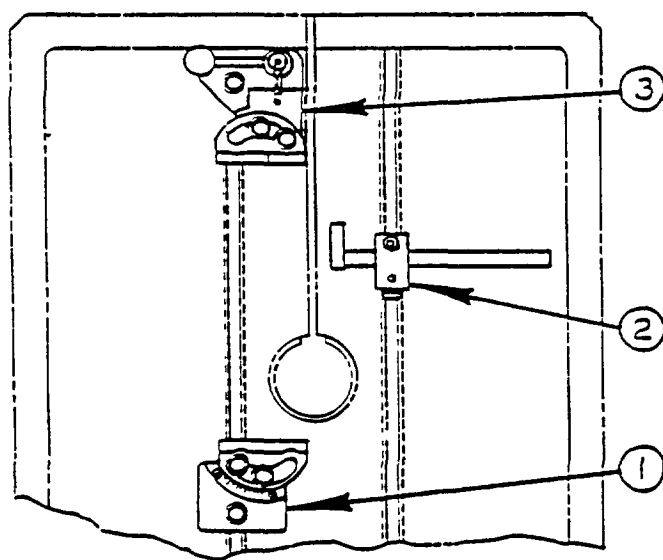

*40365
REAR VISE ASSEMBLY

CM-10-1

UNIVERSAL VISE ASSEMBLY

UNIVERSAL VISE ASSEMBLY

INDEX NO.	CATALOG NO.	DESCRIPTION	UNITS PER ASS'Y
REF.	090-403635	Universal Vise Assembly	
1	090-403650	. Rear Vise Assembly (See Below)	1
2	090-204538	. Cut Off Gauge Assembly (See Below).....	1
3	090-403643	. Front Vise Assembly (See Below)	1
	090-025818	. Offset Socket Wrench (Not Shown).....	1
REF.	090-204538	Cutoff Gauge Assembly	
4	135-005544	. Thumb Nut	1
5	090-204544	. Gauge Bar Assembly	1
6	090-023359	.. Head	1
7	090-023342	.. Pin	1
8	090-023367	. Body	1
9	090-025800	. T-Slot Bolt	1
10	090-033671	. Nut, Hex. 1/2-13NC.....	1
11	091-992669	. Washer 1/2 S.A.E. Std.....	1
REF.	090-403643	Front Vise Assembly	
12	090-205618	. Jaw.....	1
13	090-205634	. Jaw Support	1
14	090-033671	. Nut, Hex. 1/2-13NC.....	1
15	134-135086	. Knob	1
16	090-205600	. Cam Assembly	1
17	090-025842	. T-Slot Bolt	1
18	091-984229	. Screw, Soc. Hd. Set 1/4-20NC x 1/4 Cup Pt.....	1
19	090-025834	. Pivot Pin	1
20	090-205626	. Body	1
21	090-023227	. Adjusting Screw.....	1
22	090-025826	. Spring.....	1
23	090-023201	. Spring Stud	2
24	091-980664	. Screw, Hex. Hd. Cap 1/2-13NC x 1-1/4.....	2
25	091-992669	. Washer 1/2 S.A.E. Std	3
REF.	090-403650	Rear Vise Assembly	
26	090-205592	. Jaw	1
27	091-980664	. Screw, Hex. Hd. Cap 1/2-13NC x 11/4.....	2
28	091-992669	. Washer 1/2 S.A.E. Std	3
29	090-025768	. Escutcheon	1
30	091-988386	. Screw, Rd. Hd. Mach. #6-32NC x 1/4.....	2
31	090-205584	. Jaw and Body	1
32	090-093675	. T-Slot Bolt	1
33	090-033671	. Nut, Hex. 1/2-13NC.....	1

NEW DRG
CAA 3-7-78
REVISIONS

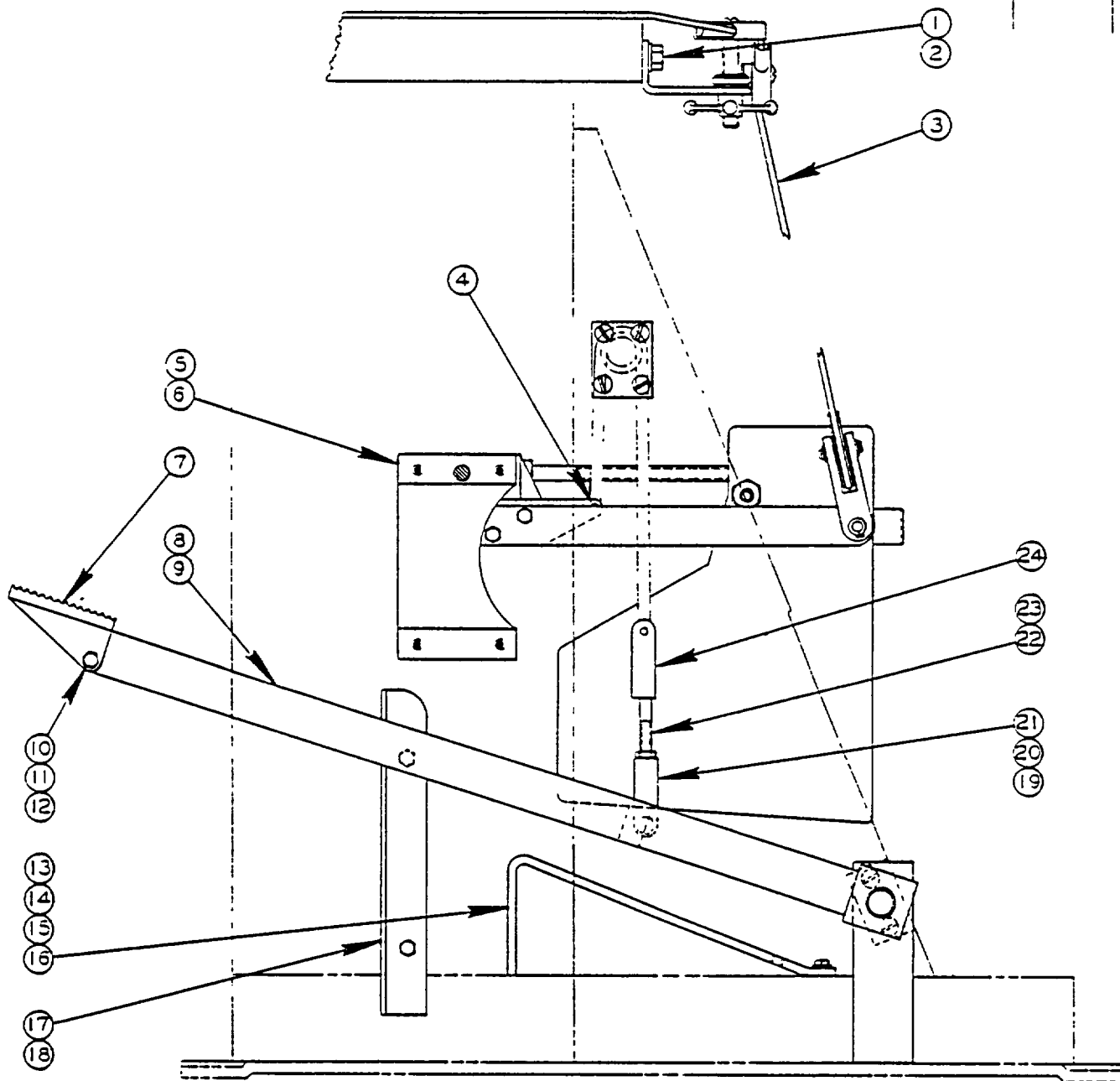

C-9-16

MODEL	FIRST MACH	LAST MACH
2013-20	377-771011	
2013-2	396-78101	
3812-2	398-78101	
3613-20	399-78101	

WEIGHT FEED ASSEMBLY

CODE NO. C-9-16

WEIGHT FEED ASSEMBLY

INDEX NO.	CATALOG NO.	DESCRIPTION	UNITS PER ASS'Y
Ref.	095-073474	Weight Feed Assembly (2013-2,2013-20)	
Ref.	095-072112	Weight Feed Assembly(Power) (3612-2,3613-20)	
1	091-980441	. Screw, Hex. Hd. Cap 3/8-16NC x 3/4	6
2	091-993329	. Washer, Lock Spring 3/8" Med	6
3	135-053221	. Carrier and Cable Assembly (See Detail)	1
4	105-134118	. Pin	1
5	090-447962	. Power Feed Hinge Assembly (See Detail)	1
6	090-042599	. Roll Pin	1
7	105-131130	. Foot Pedal	1
8	090-139965	. Dowel Pin	2
9	093-028520	. Release Lever Weldment Assembly	1
	093-028512	.. Release Lever	1
	091-306662	.. Block	1
10	091-980128	. Screw, Hex. Hd. Cap 1/4-20NC x 1 1/2.....	1
11	091-991158	. Nut, Hex. 1/4-20NC	1
12	091-993212	. Washer, Lock 1/4	1
13	094-010352	. Bracket	1
14	091-980292	. Screw, Hex. Hd. Cap 5/16-18NC x 1	2
15	091-992628	. Washer, Flat 5/16" SAE.	2
16	091-993238	. Washer, Spring Lock 5/16" Med.	4
17	093-013423	. Catch Bracket	1
18	091-980250	. Screw, Hex. Hd. Cap 5/16-18NC x 1/2	2
19	105-133169	. Anchor	1
20	091-990325	. Screw, Truss Hd. Mach. 3/8-16NC x 1 1/4.....	1
21	091-991273	. Nut, Hex. Jam 3/8-16NC.....	2
22	091-980466	. Screw, Hex. Hd. Cap 3/8-16NC x 1	5
23	091-991265	. Nut, Hex. 3/8-16NC	2
24	135-050128	. Release Lever Chain Assembly	1
	105-135107	.. Chain	1
	105-133144	.. Anchor	1
	091-995472	.. Rivet, Rd. Hd. 3/16 x 5/8	1

NEW DRG. CAK 3-7-78
REVISIONS

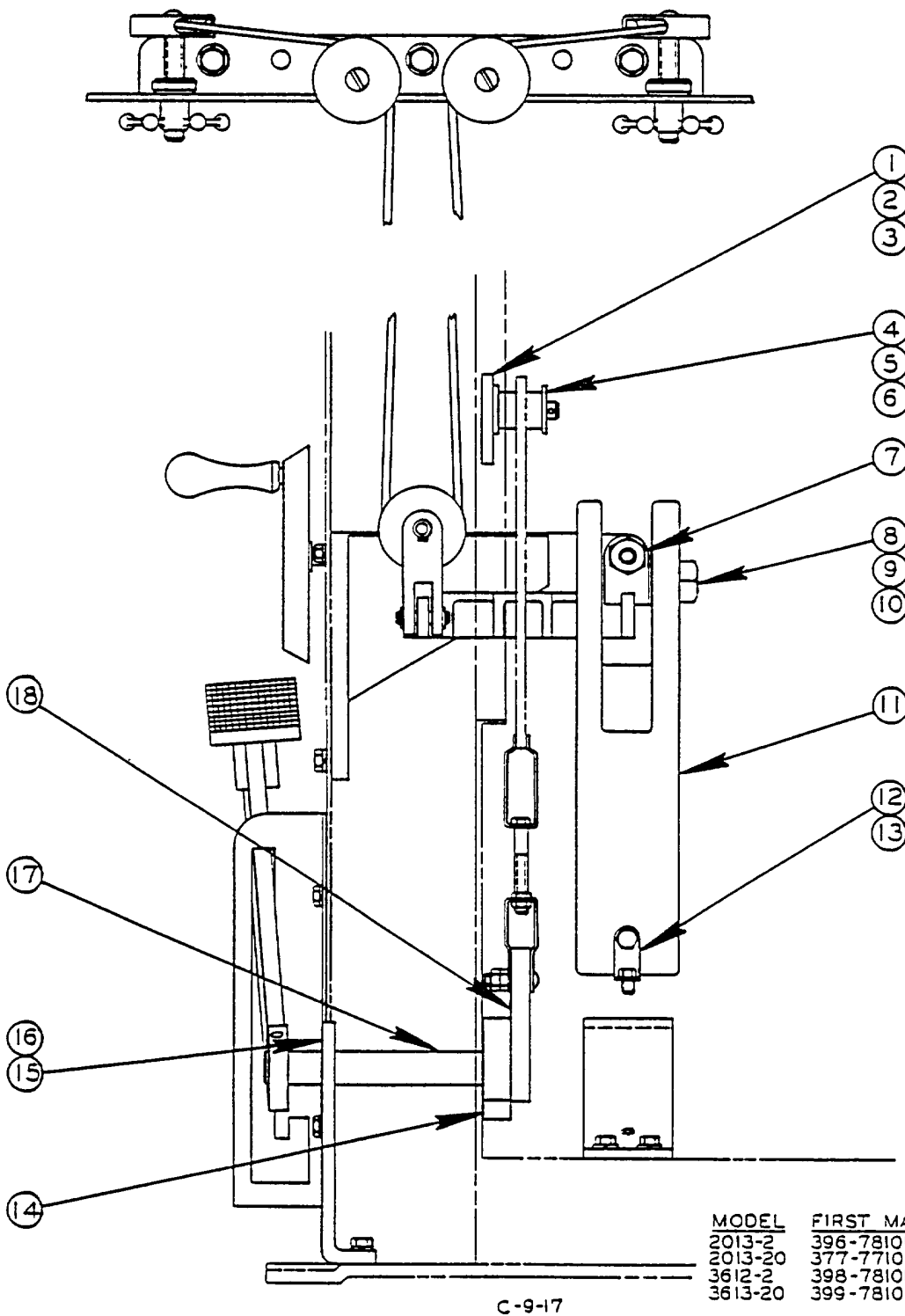

WEIGHT FEED ASSEMBLY
(CONTINUED)

CODE NO. C-9-17

WEIGHT FEED ASSEMBLY
 (continued)

INDEX NO.	CATALOG NO.	DESCRIPTION	UNITS PER ASS'Y
Ref.	095-073474	Weight Feed Assembly (2013-2, 2013-20)	
Ref.	095-072112	Weight Feed Assembly(Power) (3612-2, 3613-20)	
1	091-186957	. Bracket Weldment	1
2	091-980276	. Screw, Hex. Hd. Cap 5/16-18NC x 3/4	6
	091-987677	. Screw, Flat Hd. Mach. 5/16-18NC x 1/2.....	6
3	091-993238	. Washer, Lock Spring 5/16" Med.	6
4	091-306555	. Chain Roller	1
5	091-993048	. Washer, Flat Wrought 1/2"	2
6	091-995183	. Cotter Pin 1/8 x 1/2	2
7	105-134100	. Screw Stop Nut 1/2-13NC x 3/8	2
8	091-980748	. Screw, Hex. Hd, Cap 1/2-13NC x 3 1/2	1
9	091-993279	. Washer, Lock Spring 1/2" Med.....	1
10	091-991315	. Nut, Hex. 1/2-13NC	1
11	105-131122	. Weight	1
12	105-133086	. Weight Bracket	1
13	091-980425	. Screw, Hex. Hd. Cap 3/8-16NC x 1/2	2
14	091-475707	. Bearing Block	1
15	093-077089	. Bracket	1
16	091-992644	. Washer, Flat 3/8" SAE.	4
17	091-306563	. Shaft	1
18	091-306571	. Release Arm.....	1

NEW DRG.
C.A.R. 4-24-78
REVISIONS

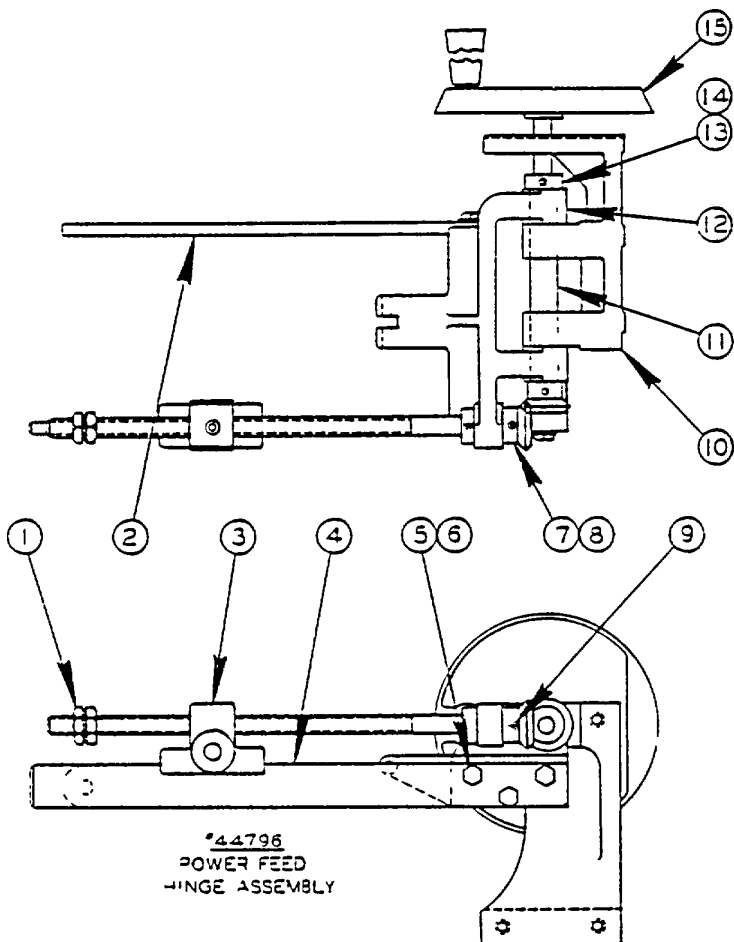

#44796
POWER FEED
HINGE ASSEMBLY

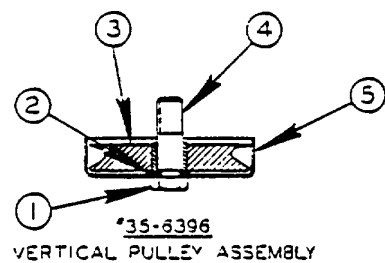

#35-6396
VERTICAL PULLEY ASSEMBLY

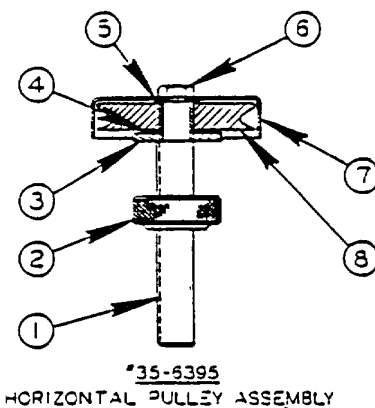

#35-6395
HORIZONTAL PULLEY ASSEMBLY

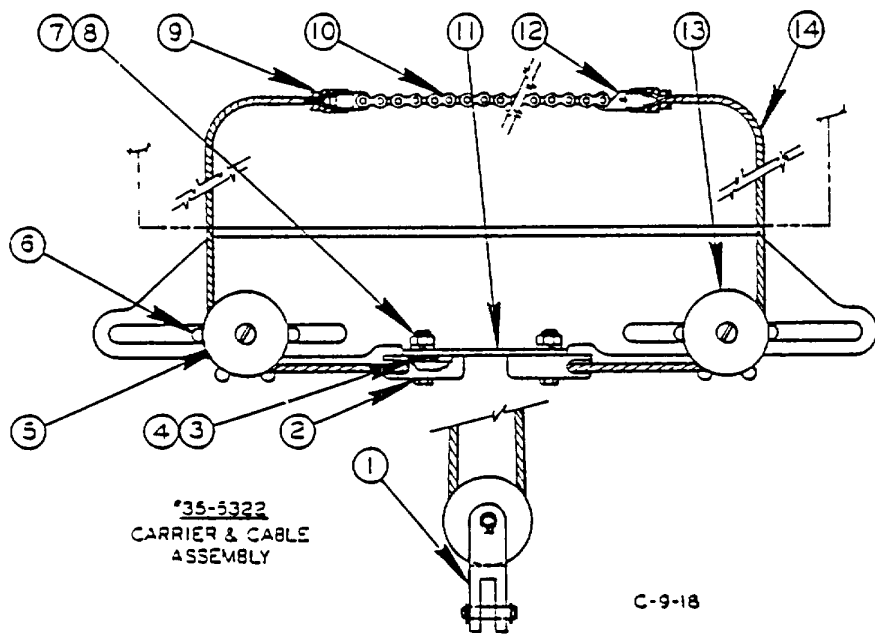

#35-5322
CARRIER & CABLE
ASSEMBLY

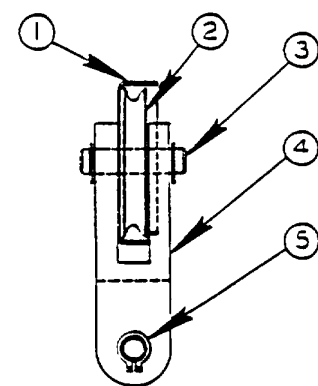

#35-7497
EQUALIZER PULLEY ASSEMBLY

MODEL	FIRST MACH	LAST MACH
2013-20	377-77101	
2013-3	396-78101	
3612-3	398-78101	
3613-20	399-78101	

C-9-18

WEIGHT FEED SUB-ASSEMBLIES

WEIGHT FEED SUB-ASSEMBLY

INDEX NO.	CATALOG NO.	DESCRIPTION	UNITS PER ASS'Y
Ref.	090-447962	Power Feed Hinge Assembly	
1	105-134100	. Stop Nut	2
2	090-167966	. Cable Beam	1
3	090-213448	. Screw Assembly	1
	105-134019	. . Weight Adjusting Screw 1/2 x 14"	1
	105-131056	. . Weight Grace	1
4	090-168717	. Weight Beam	1
5	091-980458	. Screw, Hex. Hd. Cap 3/8-16NC x 7/8	6
6	091-993329	. Washer, Spring Lock 3/8" Med.....	6
7	090-099714	. Gear	2
8	090-042.599	. Roll Pin	1
9	091-984104	. Screw, Soc. Set #10-24NC x 1/4	2
10	090-275256	. Hinge Bracket	1
11	090-16872	. Hinge Bushing.....	1
12	090-540998	. Feed Hinge	1
13	134-054105	. Collar	2
14	091-984229	. Screw, Soc. Set 1/4-20NC x 1/4.....	2
15	090-275272	. Handwheel Assembly	1
	090-425489	. . Handwheel	1
	090-042599	. . Roll Pin	1
	090-167958	. . Shaft	1
	091-181164	. . Handle	1
	091-181172	. . Pin	1
Ref.	135-053221	Carrier & Cable Assembly	
1	135-074979	. Equalizer Pulley Assembly (See Detail)	1
2	135-063964	. Vertical Pulley Assembly (See Detail).....	2
3	134-054147	. Washer.....	2
4	105-133094	. Pulley Spacer	2
5	091-992669	. Washer, Flat 1/2" SAE	2
6	134-131069	. Handwheel	2
7	091-993329	. Washer, Spring Lock 3/8" Med	2
8	091-991273	. Nut, Hex. Jam 3/8-16NC	2
9	105-134175	. Cable Clamp Housing	2
10	135-050110	. Power Feed Chain Assembly	1
	106-135015	. . Power Feed Chain	1
	105-134191	. . Cable Clamp Eye	1
	091-995464	. . Rivet, Rd. Md. 3/16 x 7/16	1
11	135-063972	. Cable Carrier	1
12	105-134183	. Cable Clamp Hack	1
13	135-063956	. Horizontal Pulley Assembly(See Detail	2
14	105-135099	. Power Feed Cord.....	1
Ref.	135-063964	Vertical Pulley Assembly	
1	091-980052	. Screw, Hex. Hd. Cap 1/4-20NC x 3/8.....	1
2	091-9937A1	. Washer, Shakeproof Lock 1/4" Ext.....	1
3	134-135045	. Pulley	1
4	135-063998	. Pulley Stud	1
5	134-133016	. Cap.....	1
Ref.	135-063956	Horizontal Pulley Assembly	
1	135-063980	. Pulley Screw.....	1
2	134-134188	. Thumb Nut	1
3	105-133094	. Pulley Spacer	1
4	134-054147	. Washer	1
5	091-993741	. Washer, Shakeproof Lock 1/4" Ext.....	1
6	091-980052	. Screw, Hex. Hd. Cap 1/4-20NC x 3/8	1
7	134-133016	. Cap	1
8	134-135045	. Pulley	1
Ref.	135-074979	Equalizer Pulley Assembly	
1	134-133115	. Cap	1
2	134-135045	. Pulley	1
3	090-032756	. Pulley Axis	2
4	090-032749	. Clevis	1
5	090-032764	. Retaining Ring	4

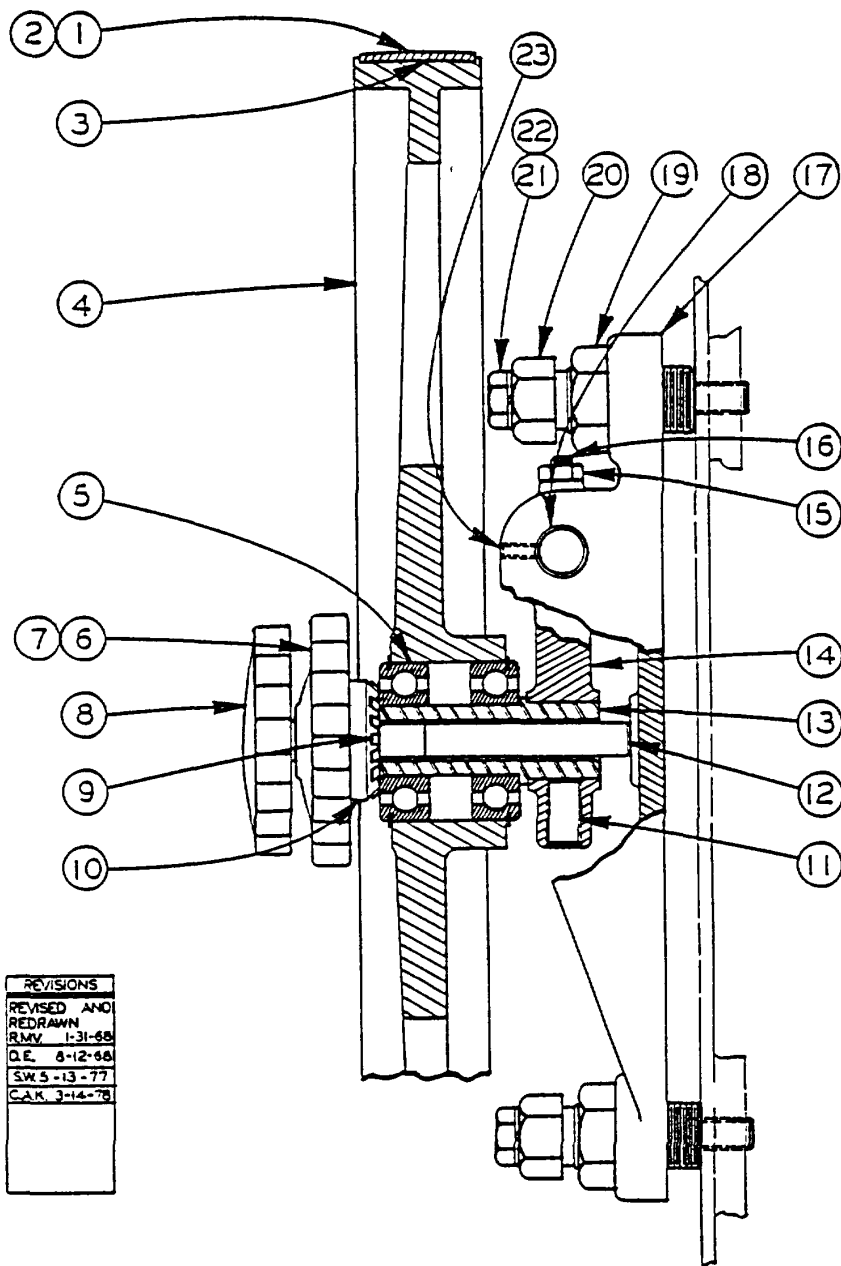

REVISIONS
REVISED AND REDRAWN
RMV 1-31-58
D.E. 8-12-58
SW 5-13-77
C.A.K. 3-14-78

THIRD WHEEL ASSEMBLY

MODEL	FIRST MACH	LAST MACH
36-2	52-53101	52-58451
3613-1	149-59101	149-73706
CS-36	111-55101	111-65116
3613-O	278-68101	278-77825
3612-U	271-68101	271-68131
3612-H	272-68101	272-77373
3612	291-68101	291-77235
3612-1	380-77101	
3613-10	381-77101	
3612-1H	382-77101	
3612-2	398-78101	
3612-2H	400-78101	
3613-20	399-78101	

C-2-28 CM-2-66

CODE NO. C-2-28
CM-2-66

THIRD WHEEL ASSEMBLY

INDEX NO.	CATALOG NO.	DESCRIPTION	UNITS PER ASS'Y
REF.	135-071124	Third Wheel Assembly (CS-36 Only)	
REF.	090-413436	Third Wheel Assembly	
1	135-051258	. Wheel Assembly (36-2 Only)	1
	135-051274	. Wheel Assembly	1
2	105-015028	. . Wheel Tire (36-2 Only)	1
	135-022705	. . Wheel Tire.....	1
3	134-015031	. . DoAll Tire Cement	A.R.
4	135-022648	. . Saw Wheel.....	1
5	105-015085	. . Wheel Bearing.....	2
6	*135-051894	. Upper Wheel Hinge Assembly (CS-36 Only)	1
	**090-215476	. Upper Wheel Hinge Assembly	1
7	105-011092	. . Upper Wheel Tilting Locknut	1
8	105-011084	. . Tilting Screw Knob	1
9	105-015077	. . Lock Washer	1
10	105-015069	. . Locknut	1
11	*091-984492	. . Screw, Soc. Hd. Set 3/8-16NC x 1/2.....	1
	**091-984518	. . Screw, Soc. Hd. Set 3/8-16NC x 3/4.....	1
12	105-014252	. . Upper Wheel Tilt Screw.....	1
13	105-014245	. . Upper Wheel Axis Stud.....	1
14	*135-093516	. . Wheel Hinge	1
	**090-215468	. . Wheel Hinge	1
15	091-991141	. . Nut, Jam 1/4-20NC	1
16	090-038621	. . Set Screw Dog Pt.	1
17	*090-012394	. Third Wheel Bracket	1
	**090-412644	. Third Wheel Bracket	1
-18	*090-012782	. Hinge Pin	1
	**135-086106	. Hinge Pin	1
19	091-991422	. Nut, Jam 3/4-16NF.....	3
20	090-059569	. Adjustable Screw	3
21	**091-980532	. Screw, Hex. Hd. Cap 3/8-16NC x 2-3/4.....	3
	*091-980482	. Screw, Hex. Hd. Cap 3/8-16NC x 1-1/2.....	3
22	091-993329	. Washer, Lock 3/8 S td.....	3
23	**091-984286	. Screw, Soc. Hd. Set 1/4-20NC x 1"	2
	*091-984252	. Screw, Soc. Hd. Set 1/4-20NC x 1/2.....	2
24	*111-013082	. Hinge Bracket Spacers (Not Shown)	A.R.

*NOTE: Items With One Star Are Parts of Assembly #135-071124.

**NOTE: Items With Two Stars Are Parts of Assembly #090-413436.

NEW DRG
S.W. 4-17-72
REVISIONS
SCL. 11-14-74
S.W.5-13-77
S.W.5-30-78

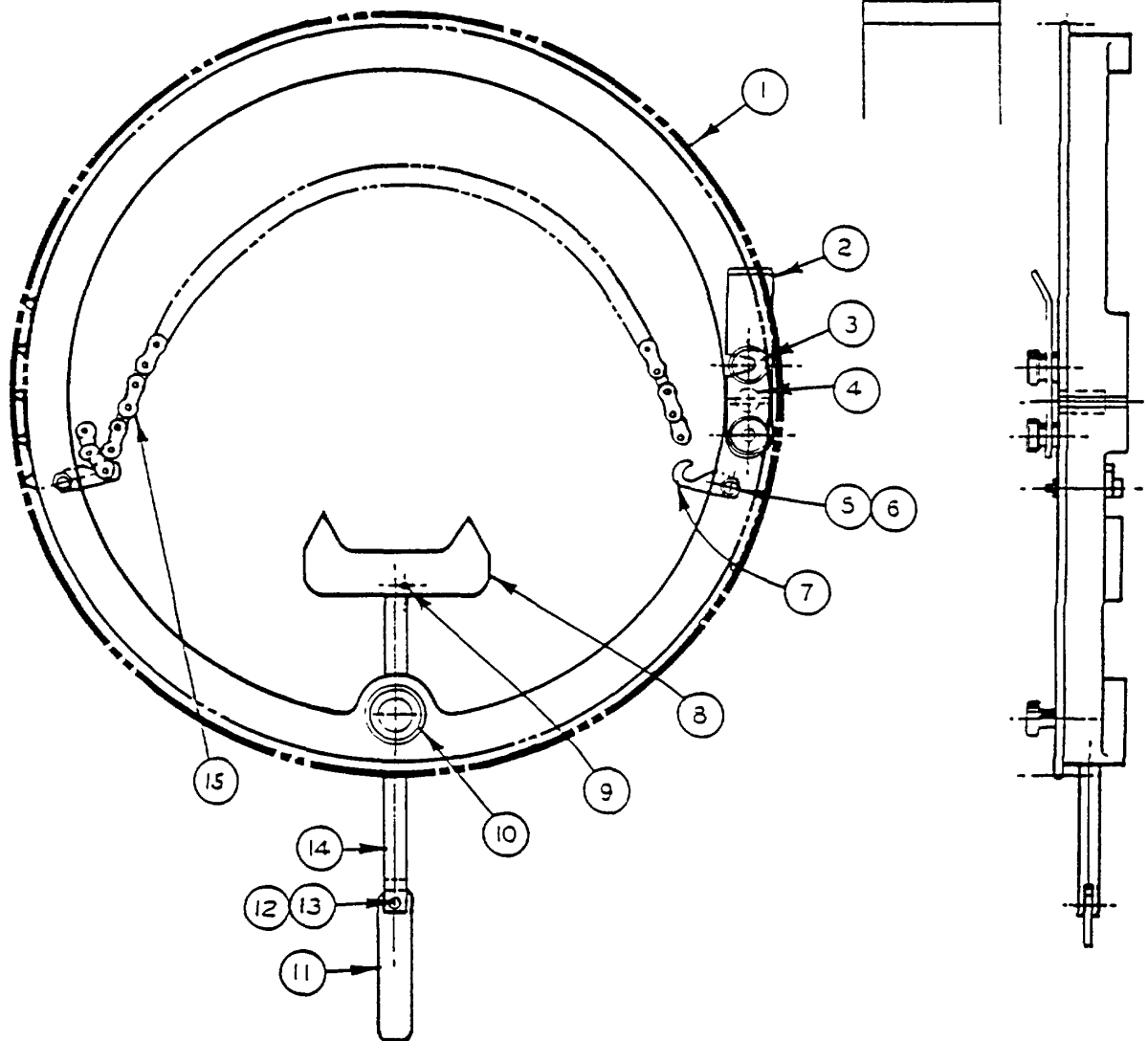

#403310
 CONTOUR FEED
 WORK HOLDING FIXTURE

C-3-77 CM-3-75

CONTOUR FEED WORK HOLDING FIXTURE

INDEX NO.	CATALOG NO.	DESCRIPTION	UNITS PER ASS'Y
Ref.	094-033107	Contour Feed Work Holding Fixture	
1	095-015160	. Clamping Ring	1
2	091-253328	. Clamp	1
3	091-339705	. Clamp Screw	2
4	090-130428	. Dowel	1
5	091-991117	. Nut, Hex. #10-24NC.....	2
6	091-982272	. Screw, Soc. Hd. Cap #10-24NC x 1 1/2.....	2
7	135-003291	. Chain Connector	2
8	091-253351	. Jaw	1
9	090-042557	. Roll Pin	1
10	091-253377	. Screw Feed Sub-Assembly.....	1
11	091-253385	. Handle	1
12	091-052639	. Belleville Washer	1
13	090-042516	. Roll Pin	1
14	091-253344	. Screw	1
15	091-253336	. Chain.....	1
	091-253401	. Chain Assembly (Not Shown)	1

REVISED AND REDRAWN
S.C. 12-27-14

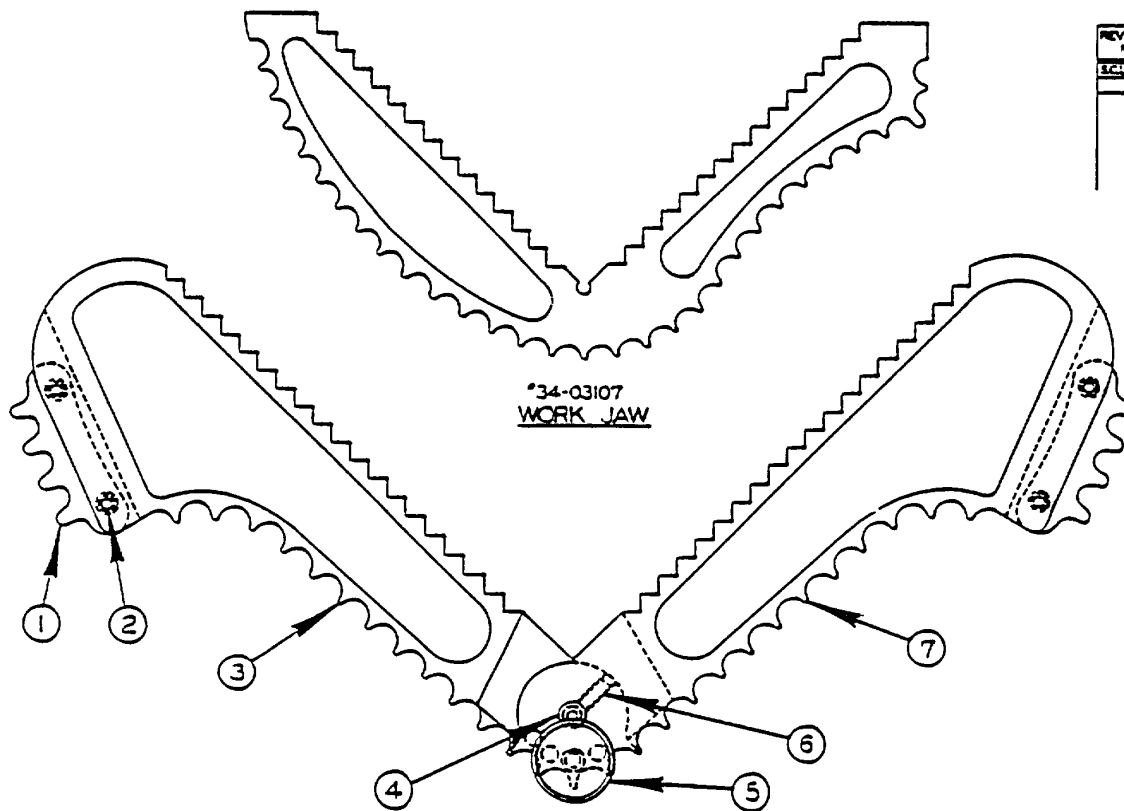

#40262
WORK HOLDER ASSEMBLY

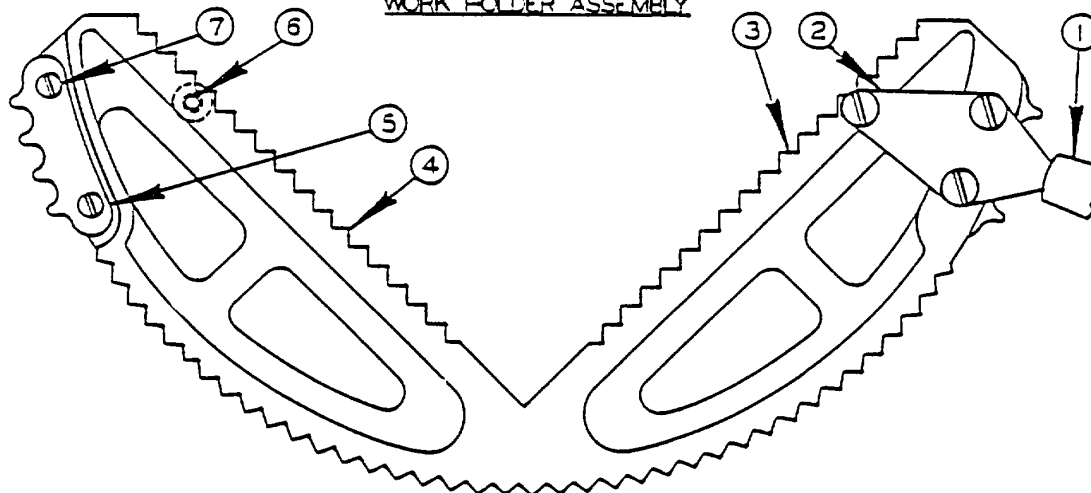

#5-13007
WORK HOLDING JAW ASSEMBLY

C-10-16 CM-9-5 Z-9-3

CODE NO. C-10-16
CM-9-5
Z-9-9

WORK HOLDING JAW

INDEX NO. REF.	CATALOG NO.	DESCRIPTION	UNITS PER ASS'Y
	134-031079	Work Jaw	
REF.	090-402629	Work Holder Assembly	
*1	105-133136	. Sprocket.....	2
2	091-986984	. Screw, Fil. Hd. Mach. #10-24NC x 1/2.....	4
3	090-203860	. Left Arm.....	1
4	091-982355	. Screw, Soc. Hd. Cap 1/4-20NC x 3/8.....	1
5	090-021627	. Knurled Screw.....	1
6	091-984104	. Screw, Soc. Hd. Set #10-24NC x 1/4.....	2
7	090-203852	. Right Arm.....	1
REF.	105-130074	Work Holding Jaw Assembly	
1	105-135123	. Handle	2
2	105-133185	. Handle Bracket	2
3	090-406786	. Work Holding Jaw Sub-Assembly	1
4	105-131106	. . Work Holding Jaw	1
*5	105-133136	. . Sprocket	2
6	091-988923	. . Screw, Rd. Hd. Mach. 1/4-20NC x 5/16	6
7	091-990150	. . Screw, Truss Hd. Mach. #10-24NC x 3/8	4

*NOTE: Before 2/12/44 On Hydraulic Machines Use #106-233372 Sprocket
 With 3/16" Pitch, Specify Pitch Of Chain When Ordering.

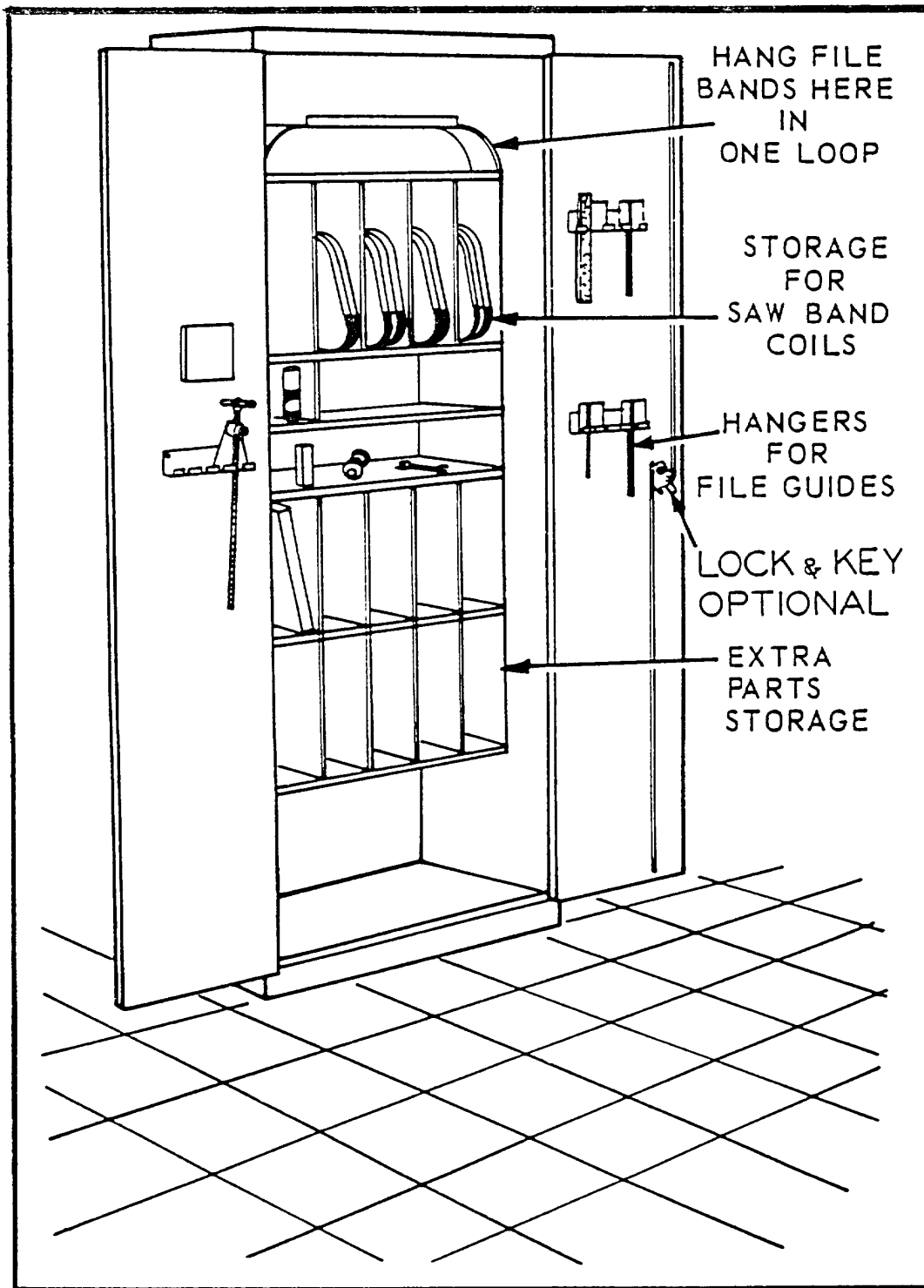

43033
SUPPLY CABINET ASS'Y.

ALL MACHINES

C-10-40, CM-10-41, PS-10-17
TF-5-110, Z-10-18, F9-7.0, G6-10.0

INSTRUCTION AND PARTS MANUAL

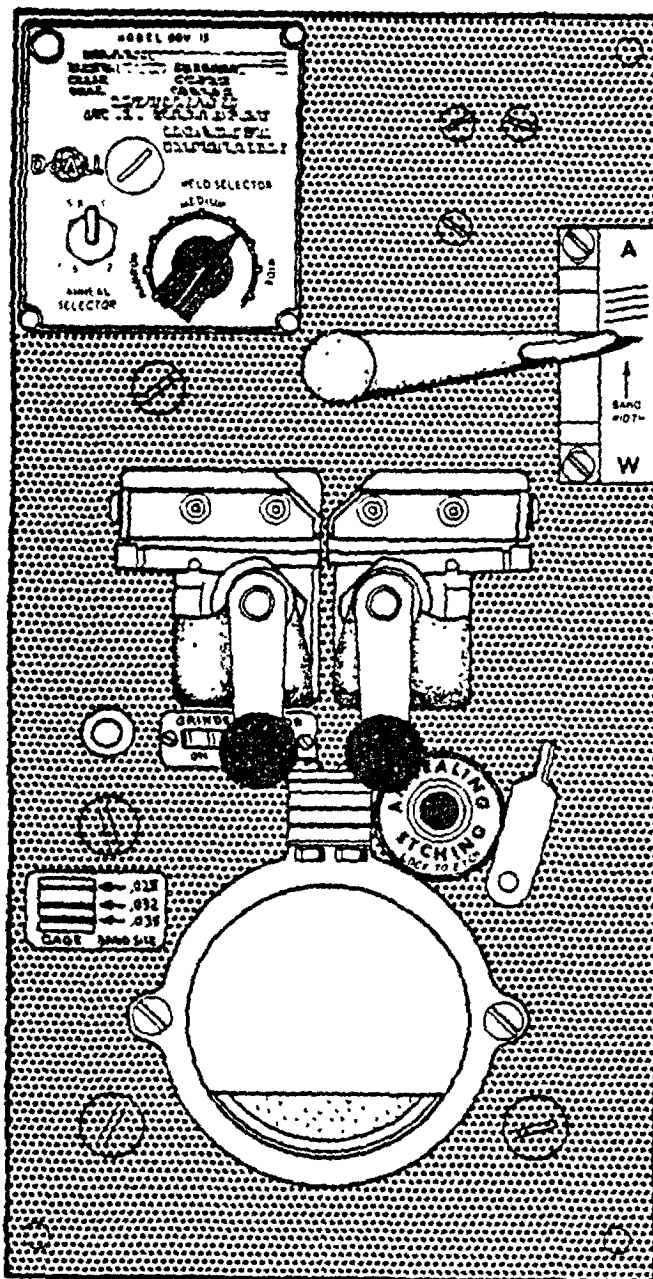

Model DBW-15
BUTT WELDER

CHAPTER 1 INSTALLATION

LOCATION

Locate the welder so that the operator will have sufficient room for handling and welding saw bands. Space should be allowed so that the coiled band will not injure persons passing nearby. The welder should also be located so that the welding sparks will not ignite flammable material.

ELECTRICAL CONNECTIONS (PORTABLE ONLY)

The welder must be connected to an electrical power line of sufficient capacity to provide for the instantaneous load specified on the data plate. The welder should be fused according to the amperage on the data plate. Refer to the wiring diagram supplied with the welder. The welder will not operate on direct current.

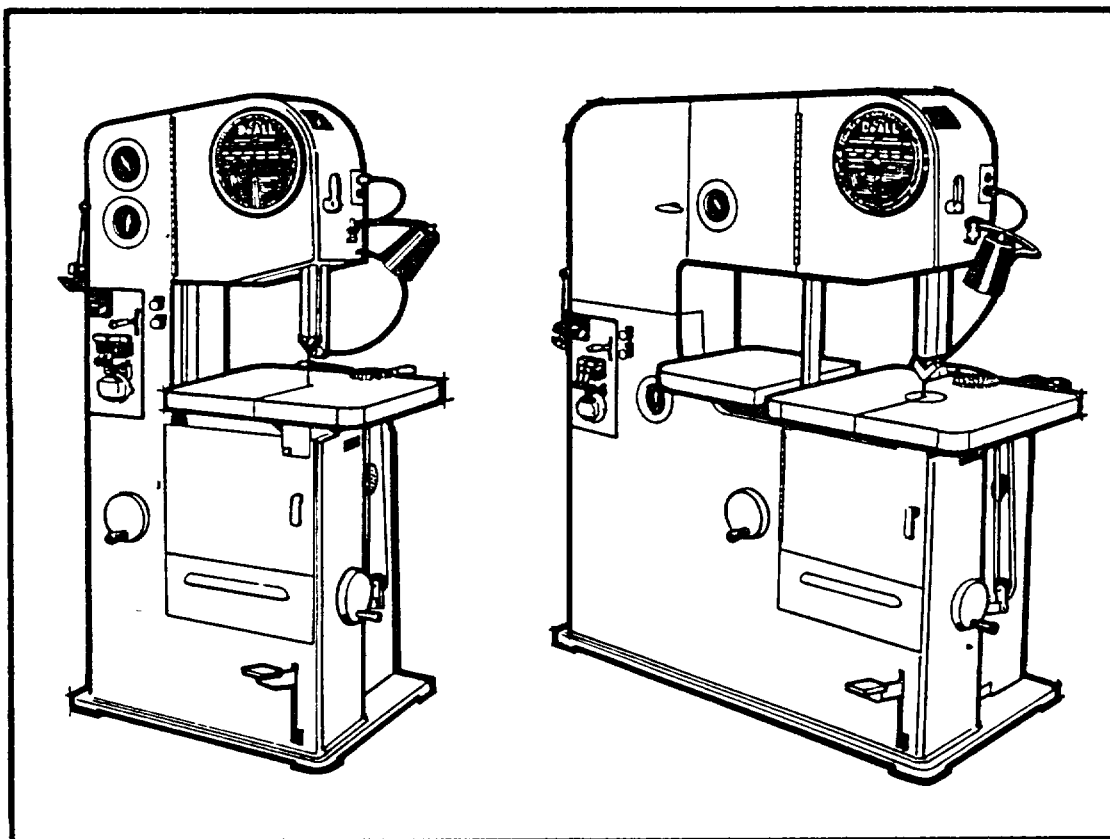

The welder may be installed on sawing machines. The location is convenient for welding bands to fit over two or three band wheels of saw. Correct band length for the machine is stamped on a data plate attached to the rear of the machine column.

CHAPTER 2

OPERATING FEATURES

GENERAL DESCRIPTION

The Model DBW#15 is a "resistance -type" butt welder, The two clamping jaws of the welder hold the butted band ends together. When the welding switch lever is pressed, an electric current is induced through the butted band ends, creating enough heat to soften and join them.

Pressing the welding lever also releases a spring which causes the jaws to force the band ends together. The electrical current is shut off before the movable jaw completes its movement. Final upset or "forging" occurs when the band is still hot, but is no longer being heated by its electrical energy source.

JAW GAP AND UPSET FORCE CONTROLS

The initial gap between the welder jaws and the spring upset force must both be adjusted in proportion to the cross-sectional area of the band being welded. A greater jaw gap will allow a wider or thicker band to reach its proper welding temperature. A greater upset force produces the same unit pressure in welding a wider or thicker band.

A jaw upset force selector is used to provide a variable control of upsetting force. Initial jaw gap is set by adjusting the position of the weld lever before making the weld.

ANNEALING

When the band is heated in the butt welding process, the steel at the point of weld "air-hardens" and becomes brittle. The annealing push button is used to "anneal" the weld by reheating it. This returns the band to an approximation of its original condition. A selector switch is provided for choosing the correct annealing heat, depending upon the width of the saw blade.

WELD GRINDER

The grinding wheel is used to prepare the blade for welding and to remove flash from the weld. Flash on both sides of the weld must be ground off to blade's thickness. The gage at the top of the wheel guard is used to check for complete removal of the flash. After grinding, the weld should pass freely through this gage.

Since it may be difficult to see if the grinding wheel is rotating, a pilot light is provided as a safety feature. This light is "on" when the grinding motor is running.

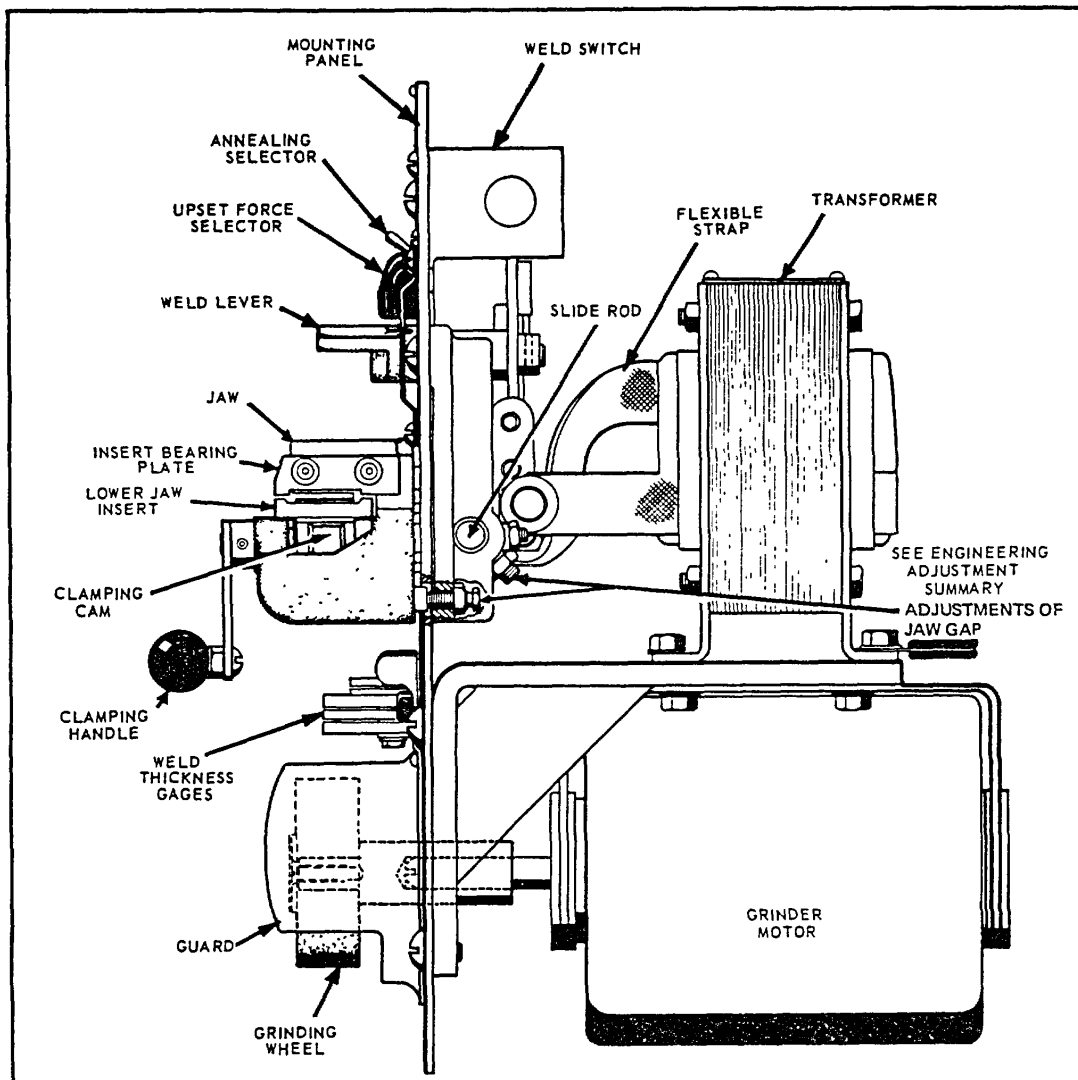

Side View of the welder, showing features and controls.
(Current design shown)

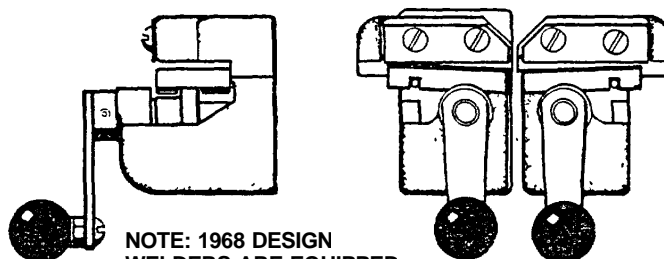

NOTE: 1968 DESIGN WELDERS ARE EQUIPPED WITH SLIGHTLY DIFFERENT JAWS AND INSERTS, AS SHOWN HERE.

CHAPTER 3

OPERATION

PREPARING THE BLADE

- (1) Cutting the Blade: Cut the saw blade to length. Use the blade shear if it is available. Using the blade shear will insure that the blade ends are flat, square and smooth.
- (2) Tooth Spacing: In fine pitched bands, one or more teeth on each side of the cut must be removed by grinding, so that the cross section of the weld area of the band is uniform. This will also insure proper tooth spacing at the weld area and that the set pattern of the teeth will be retained.

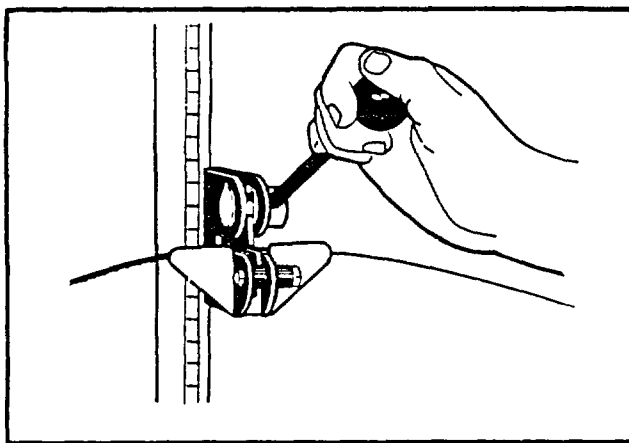

Using the Blade Shear.

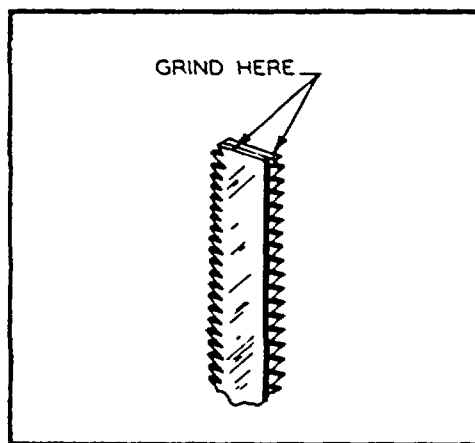

If snips are used to cut blade, grind ends square as shown.

NOTE

If the Blade Shear has not been used to cut the blade, square the ends of the blade before welding. Grind both ends of the saw blade in one operation as shown in the sketch. Hold the ends so that the teeth point in opposite directions. Regardless of the angle of grinding, the two ends will match perfectly when turned over.

- (3) Clean the band: Use No. 120 grit emery cloth or equivalent for this operation. Care must be taken so that the teeth are not touched with the emery cloth, because the set or sharpness of the teeth could be damaged. The part of each end of the band that comes into contact with the inserts must be sanded. Any dirt, oil, oxide or scale that is not removed will prevent good electrical contact. The oxide on Dart Blade must be removed.

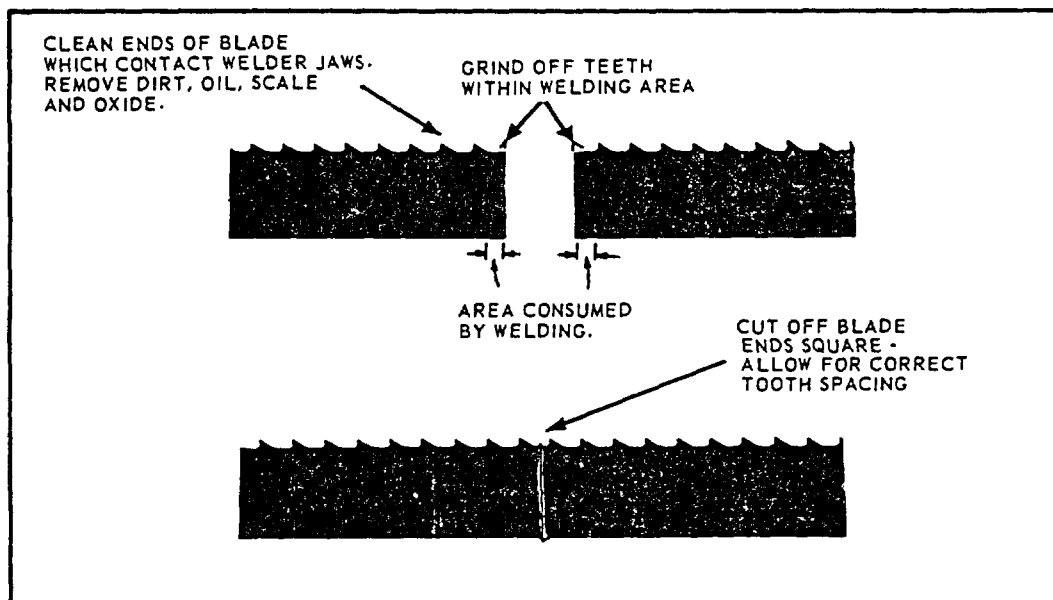

Points to remember in preparing the blade for welding.

PREPARING THE WELDER

- (1) Clean the welder jaws.
- (2) Remove and clean the lower jaw inserts.
- (3) The jaw upset force selector control should be set to the correct position for the width of saw blade being welded.
- (4) Set the "initial jaw gap" by adjusting the position of the weld lever, according to the blade width.

NOTE

The jaw upset force and initial gap between the welder jaws must both be increased in proportion to the increase in cross-sectional area of the blade being welded. In other words, the upset force and initial jaw gap must be increased for a thicker blade as well as a wider blade. A greater jaw gap and upset force will allow a wider or thicker blade to reach its proper welding temperature.

Because there are so many variables involved (such as the different widths, types and gages of blades, as well as variations between welders), it is difficult to establish recommended jaw gap and upset force settings. The settings that provide the best welds for each width, gage and type of blade should be determined by experience and noted for future use.

SAW BLADE ALIGNMENT BEFORE WELDING

- (1) For internal sawing, the blade is inserted through the starting hole in the work. The ends of the saw blade are then brought together to be clamped into the jaws.

When rewelding a used band cut out the old weld - it is recommended that the saw band contain only one weld.

NOTE: When welding band which passes through hole in workpiece - be sure to insulate band from contact with workpiece or table, this will insure a better weld.

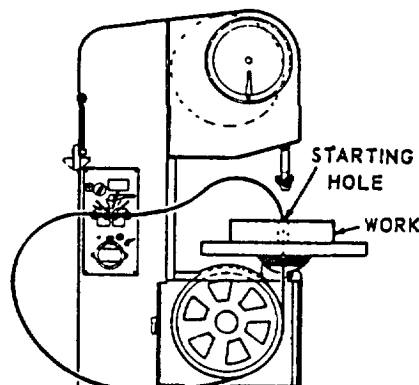

- (2) Place the band ends between the jaws with the teeth against the line-up guides which are attached to the front edge of the jaws, see sketch. **NOTE:** Blades which are 1/8 inch or less in width are too narrow to be clamped correctly when they are placed against the line-up plates. Move these narrow blades back slightly from the line-up plates and align them by eye, then clamp them in place.

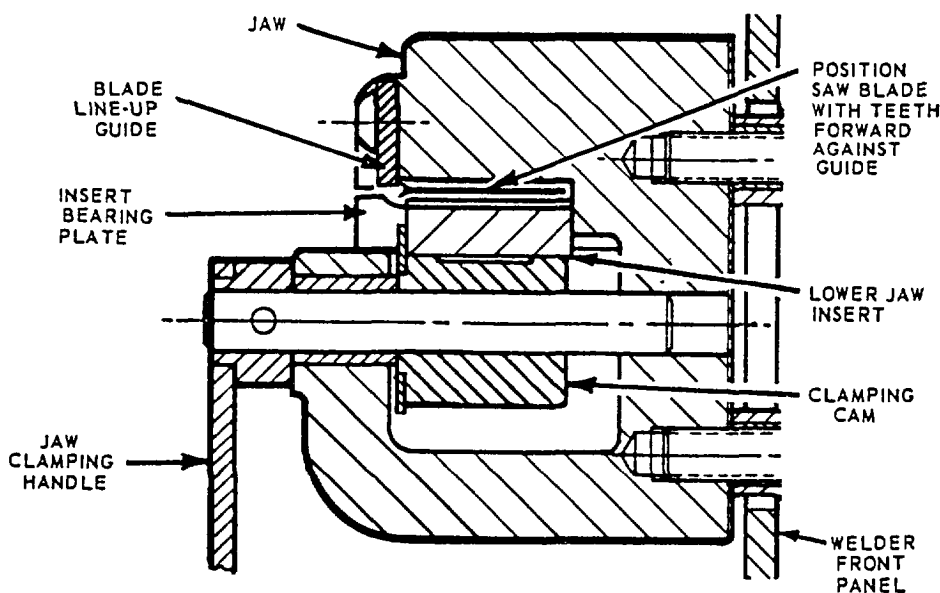

- (3) The jaws are clamped by moving the handles upward.
- (4) Check to be sure that the band ends meet in the center of the jaw gap without any offset either in thickness or across the width. If the contact across the width is not complete, remove one end and recut it. A misaligned joint will cause an incomplete weld.

MAKING THE WELD

STEP TO ONE SIDE TO AVOID WELDING SPARKS.

- (1) Press (using a smooth and steady motion not too fast or slow) and hold down the weld lever to make the weld. The lever should be held down until the weld has cooled.
- (2) Release the stationary jaw clamping handle before releasing the weld lever. This will prevent scoring the welder jaw surface.
- (3) Release the weld lever. When the lever is released, the welder mechanism and electrical switches are automatically recocked.

Special note only for IMPERIAL BI-METAL Saw Band or very narrow carbon band: In order to protect the weld from accidental breakage, it is recommended that the weld be annealed before it is removed for grinding, as well as after grinding. Follow the annealing instructions given on a following page.

- (4) Remove the welded saw band. Inspect the weld as described on the next page. If weld is poor, see the Trouble Shooting Chapter for possible causes.

CLEAN-UP WELDER JAWS AFTER WELDING

It is important that the welder jaws be kept clean at all times. The jaws and inserts must be wiped or scraped clean after every weld. Doing this will insure better welds by:

- (1) Holding proper alignment.
- (2) Preventing flash from becoming embedded in the band.
- (3) Preventing shorts or poor electrical contact.

INSPECTION OF THE WELD

When the band is removed from the welder it should be inspected carefully. The spacing of the teeth should be uniform and the weld should be located in the center of the gullet. Major jaw misalignment is easily noted at this time from the weld appearance. See the Trouble Shooting Chapter if the weld is imperfect.

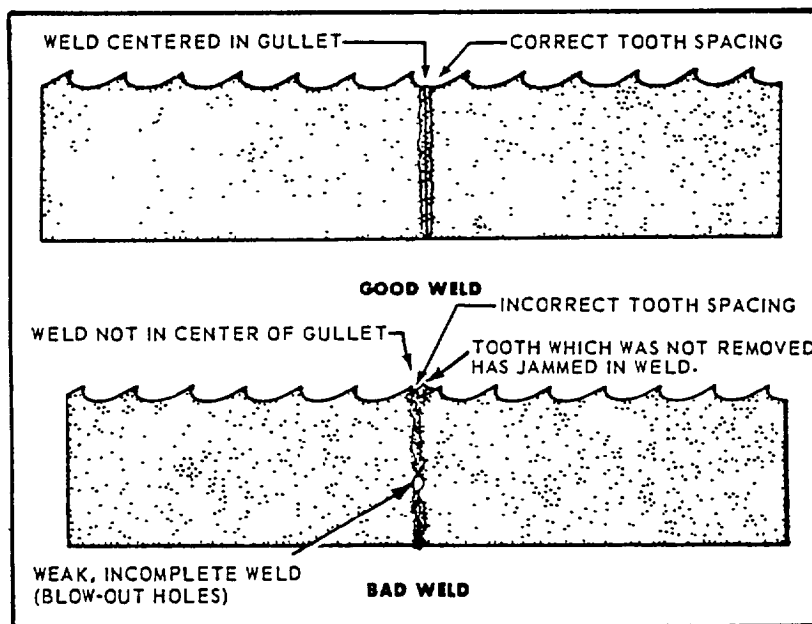

Some of the characteristics of good and bad welds.

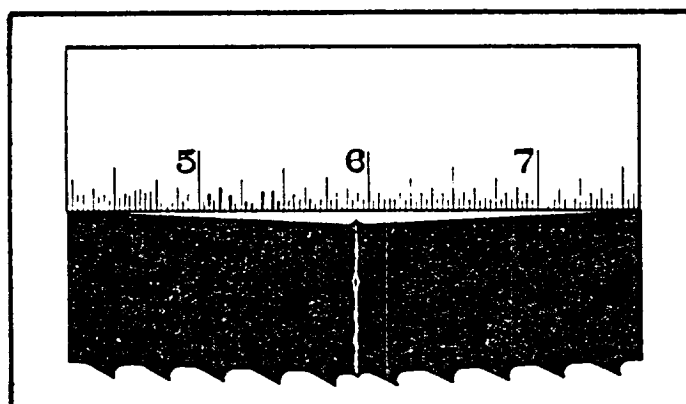

Hold a straight edge to the back edge of the band to check for misalignment.

GRINDING THE WELDED BAND

WARNING

Keep hands away from rotating grinding wheel. Because it may be difficult to see if the wheel is rotating, a pilot light is provided. This light is "on" when the grinder motor is running.

After welding, the band must be dressed to remove excess metal or flash from the weld. Grind the welded area down to the same thickness as the rest of the band. With the teeth facing out, grind the weld as shown in the drawing. Handle the band carefully the weld will be brittle because it has not been annealed.

Grind Carefully: do not hit the teeth; or grind deeper than the thickness of the band; or burn or overheat the weld area. Be sure to remove flash from the back edge of the band. Any flash or "stub" teeth which project beyond the normal set or height of the other teeth must be ground off. Check the weld thickness by passing it through the correct gage for the thickness of the band.

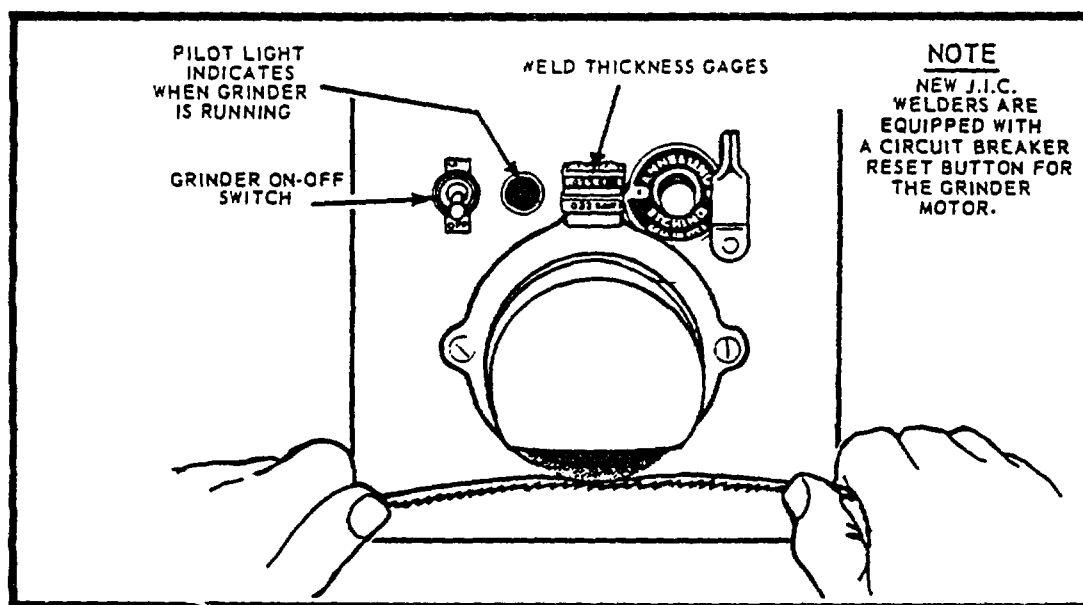

Grinding the weld.

SPECIAL NOTE FOR EARLY MODELS OF THE DBW-15

Early models of this welder had a different wiring arrangement for the grinder motor. These welders can be recognized easily because they were equipped with a grinder motor pushbutton and did not have a pilot light. On these early models only: the grinder motor will not operate if the weld lever is in its lowest position. Move the lever up before running the grinder.

ANNEALING THE WELDED BAND

- (1) Swing the weld lever up all the way to the "anneal" position which is marked by the letter "A". The lever will be held in place by the bend in the drag spring.
- (2) Clamp the band just as in welding.
- (3) Set the "anneal heat" selector switch for the width of the band.
- (4) Anneal the band as explained below. **CAUTION: Follow these instructions carefully.**
 - (a) For Carbon Blade: Press and jog the annealing switch button until the weld is a "dull cherry" to "cherry red" color. Allow the blade to cool slowly by decreasing the jogging frequency.
 - (b) For Dart Blade: Heat the blade slowly until the weld becomes a deep blue color. Continue to heat by jogging the anneal button until the width of the blue color is one-half the length of the band exposed between the jaws. Do not overheat or the temper of the band will be damaged. **CAUTION - Do not heat beyond the "blue" stage if the band begins to show any red color, it is too hot. Cool quickly by releasing the anneal button.**

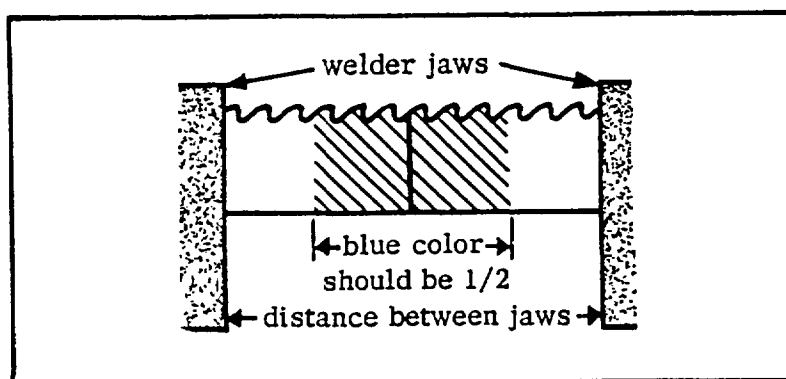

Correct annealing of Dart Blade.

- (c) For IMPERIAL BI-METAL Blade: Heat the band slowly by jogging the annealing switch button until the weld just begins to emit light (this would be the dullest red color). The desired color may not be visible in normal room light. Always shade the weld area with your hand. Cool the weld quickly by releasing the annealing button. **NOTE: This procedure should be followed both before and after grinding IMPERIAL BI-METAL Blades.**

CHAPTER 4

MAINTENANCE

LUBRICATION

The slide rod, upset force selector cam, and all miscellaneous pivot points should be lubricated every six months. The interval between lubrication may be shortened or lengthened, depending upon how much dust and dirt are in the area. If the slide rod sticks, then the rod should be cleaned and greased more often. The grinder motor will not normally require lubrication for several years. Use ASTM Grade 215 Union 76 UNAX RX 215, or equivalent oil on all lubrication points except the slide rod.

SLIDE ROD MAINTENANCE

The slide rod should be kept clean and greased. Rust or dirt may cause rod to stick and "burn out" the weld.

Check movable jaw for freedom of movement. If it binds, apply a drop of oil to slide rod and work it in by repeatedly pressing the lever. If this does not free the jaw movement, remove slide rod and clean and grease it. Before removing slide rod, clamp a piece of saw band securely between welder jaws to maintain correct spacing. Use UNION 76 UNOBA EP2 grease, or equivalent on slide rod.

The slide rod stop screw should not bind slide rod. Turn screw in, then back off 3/4 turn.

WELDER JAWS MAINTENANCE

To secure consistent results, the welder jaws must be kept clean. During the welding cycle, excess metal in the form of incandescent particles is blown out of the weld, causing a scale or flash to build up on the welder jaws. The welder will not weld properly unless the jaws are wiped clean after every weld.

Misalignment of the weld is usually caused by worn or dirty jaws. However, if the welder jaws are clean and not worn and the welds are out of line, then the jaws are not aligned properly. This misalignment can be determined by inspection of the weld after the flash has been removed. After determining which jaw is not in alignment, the jaws can be adjusted as desired. Jaw alignment instructions are given in a separate "Engineering Adjustment Summary". Replace lower jaw inserts that are worn excessively.

CUT-OFF SWITCH AND WELD SWITCH CONTACT POINTS

If the cut-off and weld switch contact points are welded together, pitted, corroded, or covered by oxide, they must be replaced. If the points are only dirty, clean them with a commercial point cleaner and clean, lintless cloth (such as linen tape).

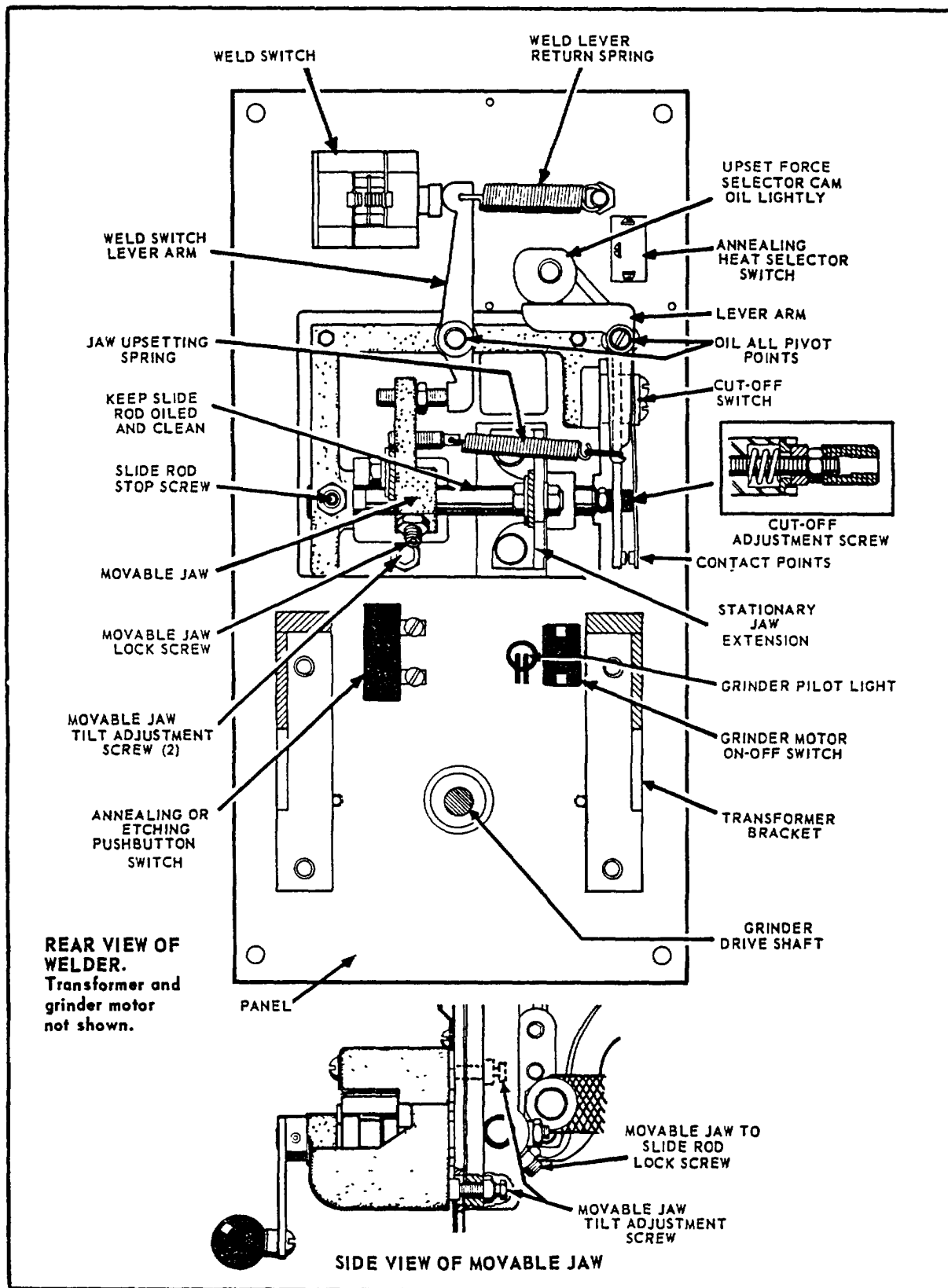

Maintenance and adjustment locations.

JAW ALIGNMENT

The importance of accurate jaw alignment cannot be overemphasized. The jaws have been carefully aligned during assembly at the factory; however, it may be necessary to align the jaws if they are bumped or damaged. The easiest and most effective way to see if misalignment exists is to actually inspect the weld joint. A misaligned weld is usually caused by worn or dirty welder jaws.

- (1) Check with a straight edge to see if the jaws are in alignment with each other with respect to elevation, inclination, and twist.
- (2) The stationary jaw can be moved slightly on its mounting screws by loosening the screws and tapping the jaw.
- (3) The movable jaw tilt is adjusted with two set screws as shown in drawing.

Detailed alignment instructions are given in a separate "Engineering Adjustment Summary".

ADJUSTMENTS (Jaw Gap, Electrical Cut-off, Upset Force)

"Incomplete" and "burned out" welds are a result of incorrect adjustments. If the weld cycle is cut off too soon, the weld will be incomplete (low heat produces a weak weld which may be only partly joined). Too long a weld cycle will produce excessive heat which will result in a "burned out" weld (excess molten metal around a discontinuous joint).

For adjusting the cut-off point, a hole in the outside leaf of the cut-off switch permits insertion of an Allen wrench into the end-knob of the slide rod (see drawing).

For all adjustments, follow the procedures given in the "Engineering Adjustment Summary".

WARNING

DISCONNECT ELECTRIC POWER TO THE WELDER BEFORE MAKING ADJUSTMENTS.

CHAPTER 5

TROUBLE SHOOTING

MISALIGNED WELD

- (1) Dirt or scale on jaws or blade.
- (2) Blade ends not cut off square.
- (3) Blade ends not correctly aligned when clamped in jaws.
- (4) Worn jaws or inserts.
- (5) Jaws are not aligned correctly.

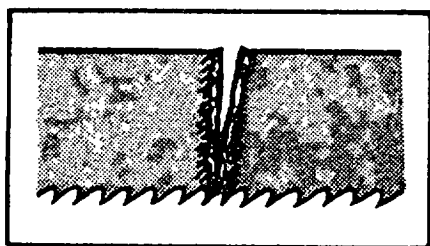

Misaligned weld.



"Overlapped" weld.

MISALIGNED WELD-BLADE ENDS ARE OVERLAPPED

- (1) Jaw upset force control set for wider blade than used, adjust correctly.
- (2) Blade ends or jaws not aligned correctly.

WELD BREAKS WHEN USED

- (1) Weld not annealed correctly.
- (2) Weld has been ground too thin.
- (3) Weak "Incomplete" weld.

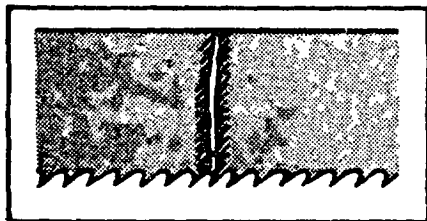

Incomplete weld.

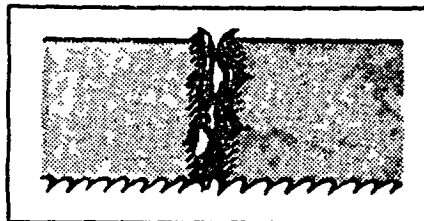

"Blown-out" weld.

INCOMPLETE WELD (joint is not complete, "blow holes" in joint)

- (1) Incorrect Initial Set-Up:
 - (a) Initial jaw gap (weld lever position) not set correctly.
 - (b) Upset force control not set correctly.
- (2) Improper clamping procedures.
- (3) Defective cut-off switch may not break the circuit at end of welding operation.
- (4) Cut-off switch not adjusted correctly.
- (5) Points of cut-off switch welded together.
- (6) Slide rod sticking because of rust or dirt. Clean and oil rod see Maintenance.
- (7) Slide rod movement obstructed because stop screw too tight on rod.
- (8) Jaw movement obstructed by kinked jaw cable or tangled wires. Bend cable and untangle wires.
- (9) Movable jaw binding on jaw bearings because of tilt adjustment screw turned in too far.

BRITTLE WELDS

- (1) Weld has not been annealed correctly, see "Annealing" in Operation Chapter. Poor annealing can be caused by:
 - a. Incorrect annealing heat. Bring weld up to correct color as described under "Annealing" in Operation Chapter.
 - b. Scale or oil on weld can cause poor annealing.

CHAPTER 6

ACCESSORIES

ETCHING PENCIL

The Etching Pencil is used with the butt welder to mark tools, jigs, fixtures, templates, etc.

To use the etching pencil:

- (1) Clamp cable end of etching pencil in welder stationary jaw. Move weld lever up to "anneal" position.
- (2) Press the anneal and etching pushbutton and clamp the button down with the etching pencil clamp. This closes the circuit through the welder and also grounds the etching current through the machine.
- (3) Place the work to be marked on the table of the machine. Since the machine is "grounded" there is no second lead required to the work.
- (4) Etch with sufficient pressure to prevent the point from arcing, but not great enough to destroy the copper point. The copper point should be kept sharp to secure best results.

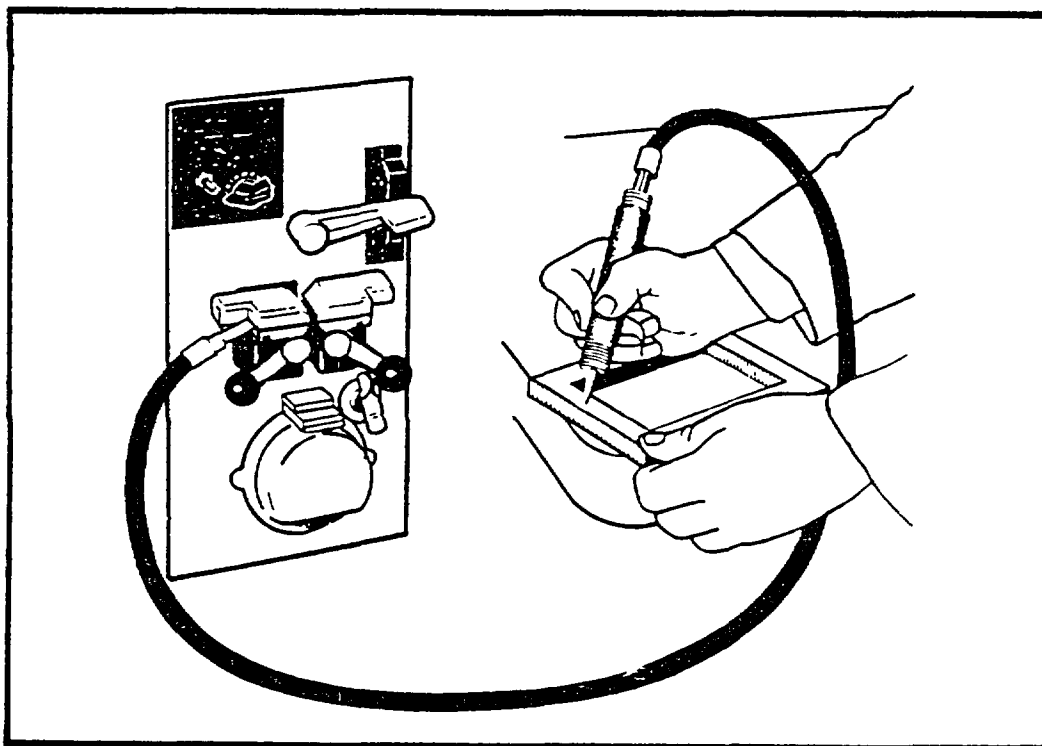

Using the Etching Pencil.

BLADE SHEAR

The cutter blades can be easily replaced. Disassemble by removing the snap rings from the pivot pin and eccentric disk. Then remove the retaining screws on the bottom blades.

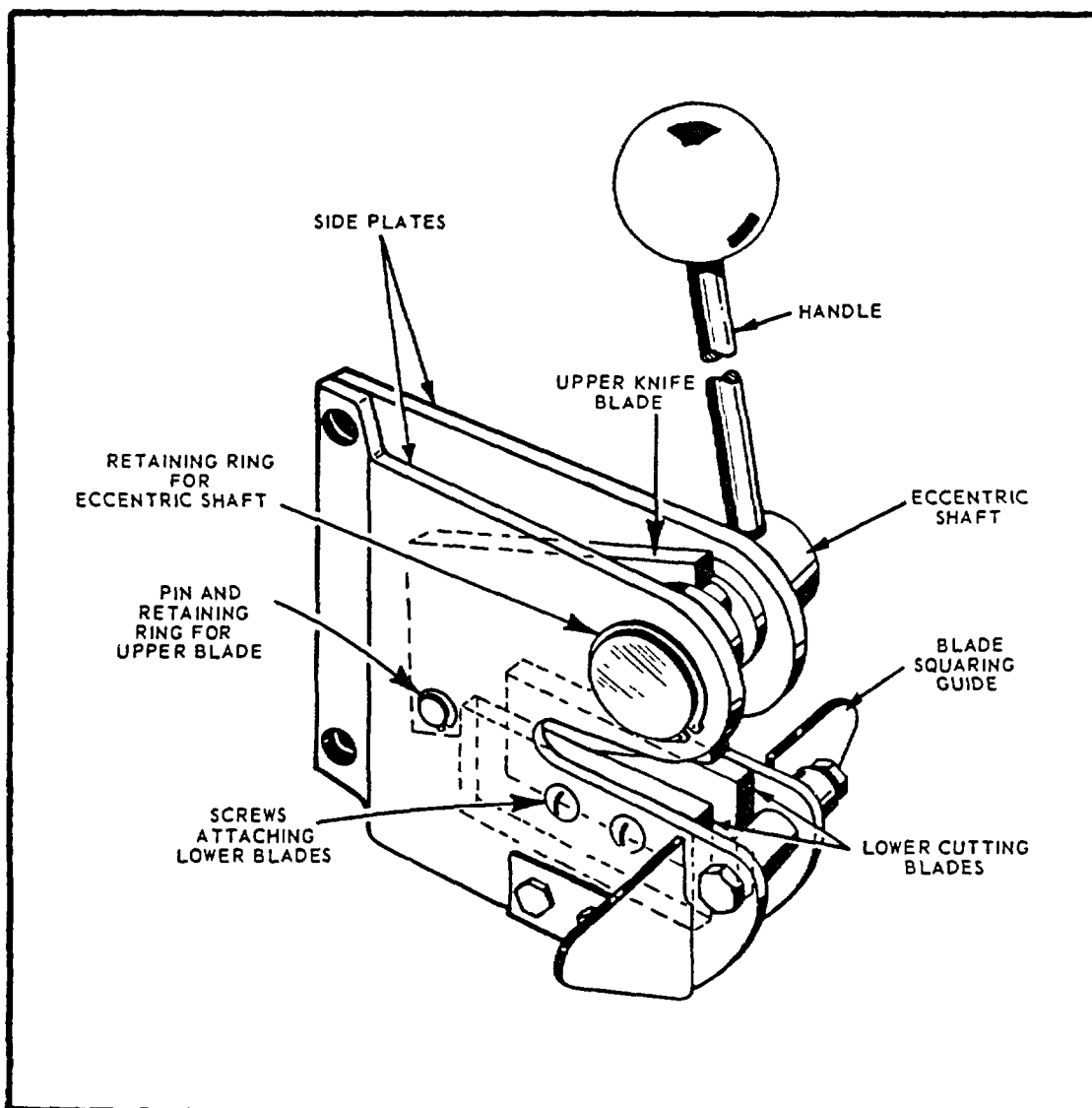

The Blade Shear Assembly.

REPLACEMENT PARTS

CATALOG

FOR

BUTT WELDER

You can avoid unnecessary delay and inconvenience by specifying correct model and serial numbers on all parts orders.

REVISED AND REDRAWN
SCL 12-18-74

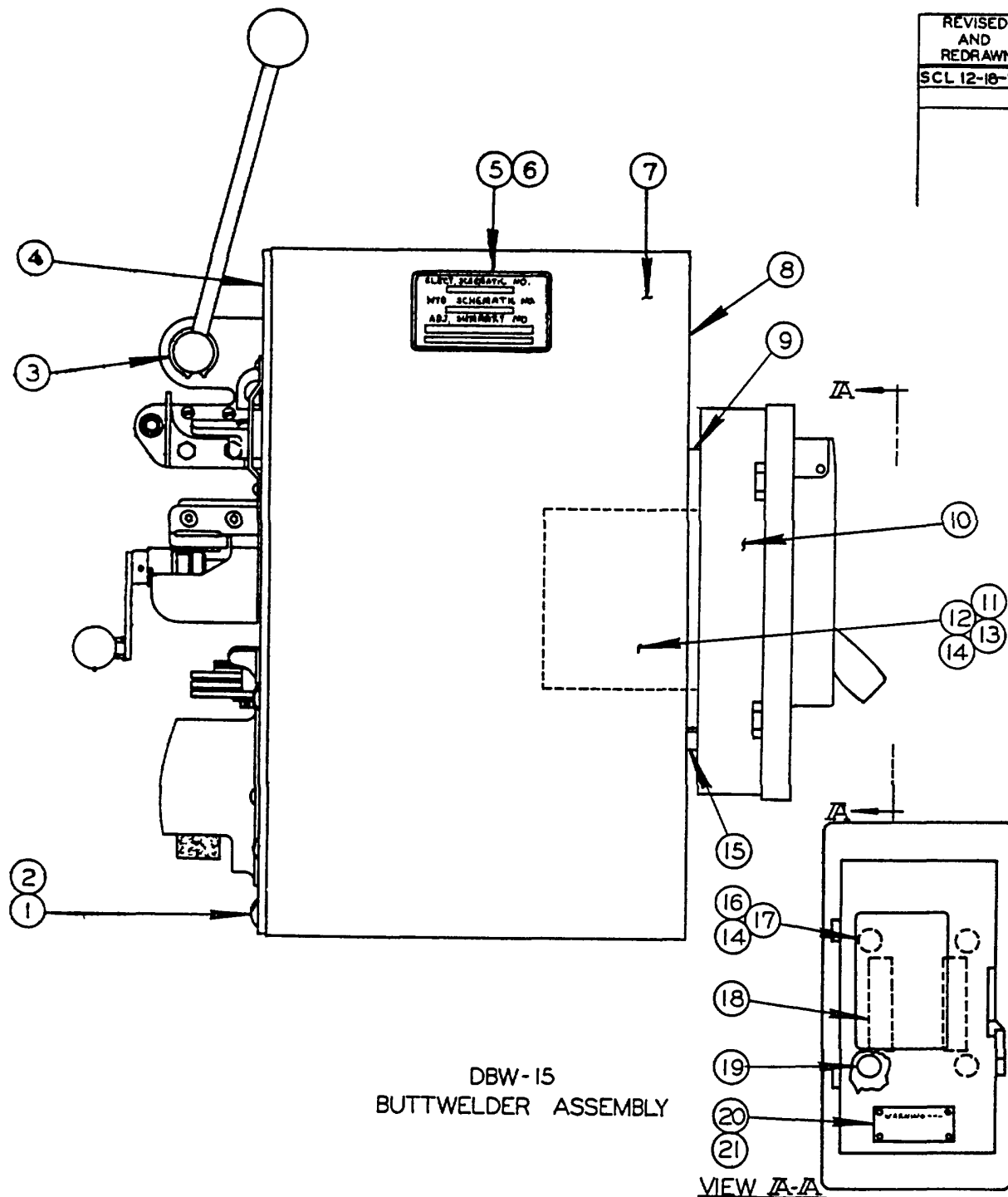

MODEL FIRST MACH LAST MACH
DBW-15 290-69101

CODE NO. H1-13.0

DBW #15 BUTTWELDER ASSEMBLY

INDEX NO.	PART NO.	DESCRIPTION	UNITS PER ASS'Y.
Ref.	401436	DBW# 15 Portable Assembly	
1	199019	. Screw, Truss Hd. Mach. 1/4-20NC x 3/8.....	4
2	199356	. Washer, Lock 1/4 Shakeproof Int	4
3	131807	. Blade Shear Assembly (See Detail).....	1
4	59788	. Buttwelder Assembly (See Detail).....	1
5	116552	. Data Plate	1
6	199396	. Screw, Rd. Hd. Drive #2 x 3/16 Type "U"	4
7	132814	.. Buttwelder Box Assembly (Std. 240 Vac.).....	USE
	132815	.. Buttwelder Box Assembly (Above 240 Vac.)	ONE
8	6-06342	.. Buttwelder Box	USE
	50528	.. Buttwelder Box	ONE
9	1927	.. Spacer (Sq. D Switch Only) (#132815 Only)	4
	10132821	.. Safety Switch 3-Pole	USE
	16180	.. Safety Switch 3-Pole	ONE
11	408838	.. Transformer (#132815 Only).....	1
12	198895	.. Screw, Rd. Hd. Mach. 1/4-20NC x 1/2 (#132815 Only).....	4
13	199321	.. Washer, Lock 1/4 Std. (#132815 Only).....	4
14	199115	.. Nut, Hex 1/4-20NC (#132815 Only).....	4
15	7506	.. Grommet	1
16	198897	.. Screw, Rd. Hd. Mach. 1/4-20NC x 3/4.....	4
17	199321	.. Washer, Lock 1/4 Std.....	4
18	133848	.. Fuse 10A-250 V.....	2
	133861	.. Fuse 5A-600 V.....	2
19	104770	.. Ground Tag	1
20	133160	.. Escutcheon ("Warning ---")	1
21	199396	.. Screw, Rd. Hd. Drive #2 x 3/16 Type "U"	4

Following Items Not Shown:

STK #714	.. Wire, #10 AWG Green.....	A.R.
STK #724	.. Wire, #12 AWG Black	A.R.

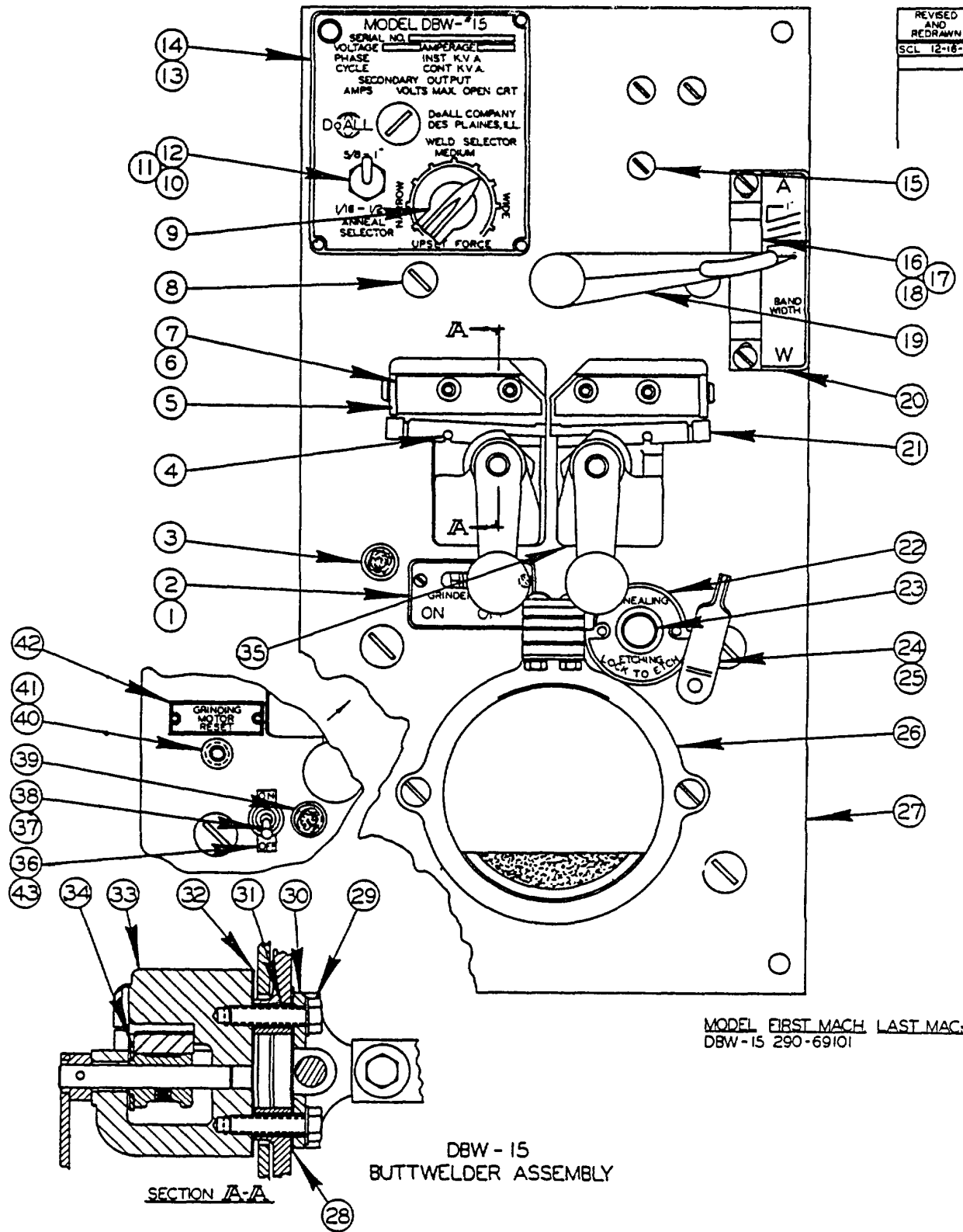

HI-13.1

CODE NO. H1-13.1

DBW #15 Buttwelder Assembly

INDEX NO.	PART NO. DESCRIPTION	UNITS PER ASS'Y.
Ref.	59788 DBW #15 Buttwelder Assembly	
1	136185 . Escutcheon (English)	USE
	136186 . Escutcheon (International)	ONE
2	198840 . Screw, Rd. Hd. Mach. #16-32NC x 3/8	2
3	114591 . Glo-Lite 240-V	1
4	119906 . Pin	2
** 5	121067 . Insert Bearing	2
** 6	121066 . Line Up Guide	2
** 7	198346 . Screw, Soc. Hd. Cap #8-32NC x 3/8 (Button)	8
8	199023 . Screw, Truss, Hd. Mach. 1/4-20NC x 3/4	2
9	34-06518 . Knob	1
10	107171 . Washer, Lock	1
11	108450 . Switch S.P.D.T.	1
12	114568 . Nut, Hex. 15/32-32 NC	1
13	119861 . Escutcheon	1
14	199397 . Screw, Rd. Hd. Drive Pk #2 x 1/4 Type "U"	5
15	199015 . Screw, Truss Hd. Mach. #10-24NC x 3/8	3
16	119880 . Drag Spring	1
17	198866 . Screw, Rd. Hd. Mach. #10-24NC x 5/16	2
18	120268 . Shim	3
19	119883 . Handle Assembly	1
	119564 . Handle	1
	119879 . Shaft	1
	4231 . Roll Pin	1
	119862 . Escutcheon	1
** 21	38660 . Jaw Insert	2
22	35-778 . Escutcheon	1
23	34-06503 . Anneal Switch	1
24	35-2010 . Pushbutton Clamp	1
25	199538 . Rivet, Rd. Hd. 1/8 Dia. x 1/2	1
26	303886 . Grinder Wheel Guard Assembly (See Detail)	1
27	59767 . Panel	1
28	2761 . Insulator	1
29	3172 . Screw, Hex. Hd. Cap	2
30	2748 . Connector	1
31	35-9614 . Insulator Bushing	2
32	119863 . Insulator	1
** 33	401871 . Stationary Welder Jaw	1
34	121477 . L.H. Cam Sub-Assembly	1
* 35	401872 . Movable Welder Jaw	1
	Following Items Not Shown:	
	133826 . Wire Connector	3
	103848 . Wire Terminal	10
	133827 . Wire Connector	1
	Stk #731 . Wire, Stranded #14 Black	A.R.
	111123 . Wire Terminal	4
	NOTE: The Following Items Are For Machines After Serial #290-68182 and Before Serial #290-745446.	
* 36	10776 . On-Off Plate (English)	USE
	131202 . On-Off Plate (International)	ONE
* 37	110953 . Toggle Switch	1
* 38	107171 . Washer, Lock	2
* 39	114591 . Glo-Lite 250-V	1
40	113262 . Circuit Breaker 1.5A E-T-A	1
41	121410 . Wire Terminal	2
42	121411 . Escutcheon (English)	USE
	131203 . Escutcheon (International)	ONE
* 43	111123 . Wire Terminal	A.R.
	NOTE: For Canadian Welders, Omit Items 36, 37, 38, 39, 43 and Replace With	
	100888 . Plug Button	2
	**NOTE: When Replacing any one part of the Double Starred Items for Machines Before Serial # 290-69396, order Item no's 5, 6, 7, 21, 33, and 35 Inclusive.	

REVISED AND REDRAWN
501 12-13-74

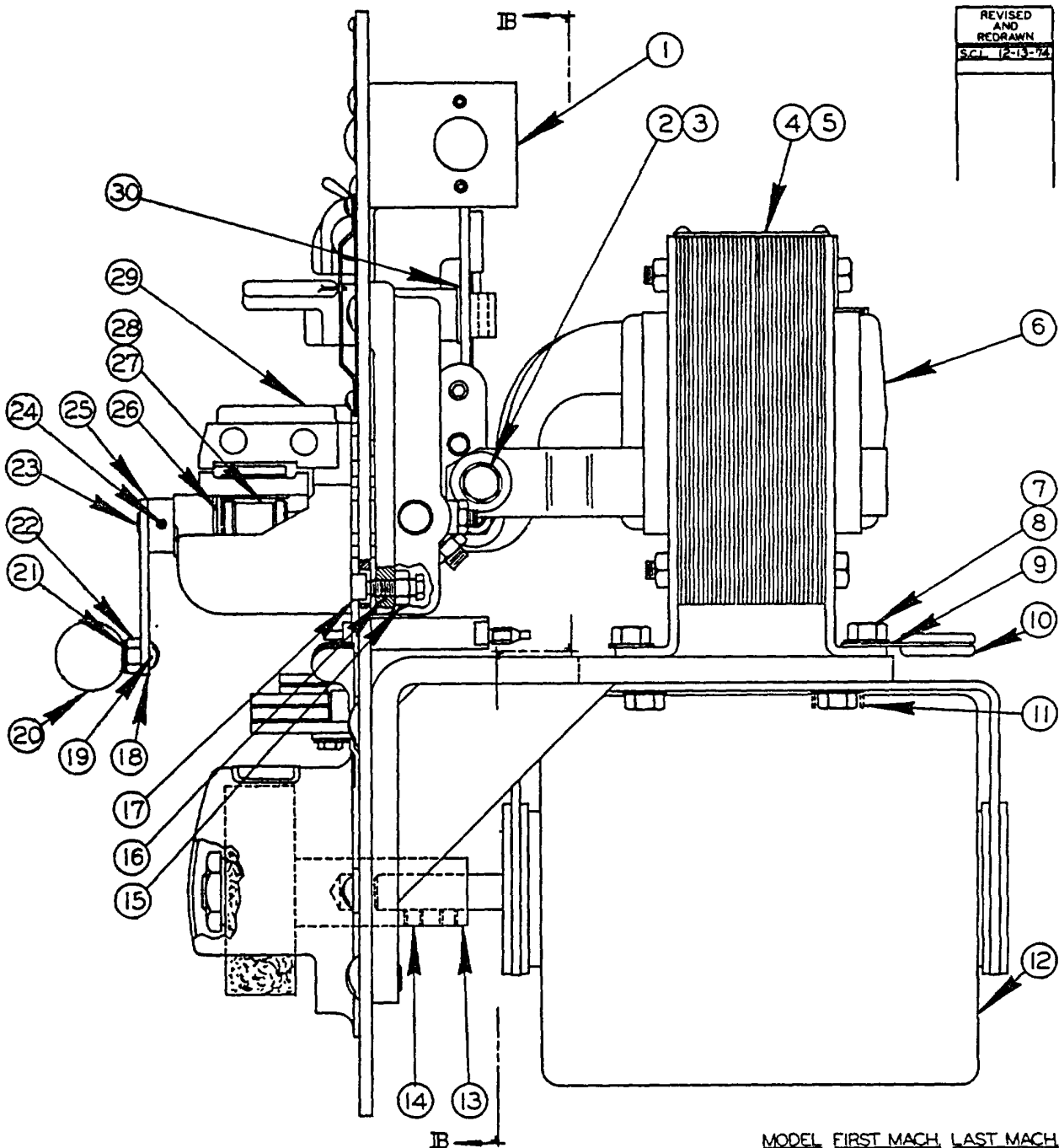

MODEL FIRST MACH LAST MACH
DBW-15 290-69101

DBW-15
BUTTWELDER ASSEMBLY

CODE NO. H1-13.2

DBW #15 BUTTWELDER ASSEMBLY

INDEX NO.	PART NO.	DESCRIPTION	UNITS PER ASS'Y.
Ref.	59788	DBW #15 Buttwelder Assembly	
1	35-9545	. Switch Bracket.....	1
2	198039	. Screw, Hex. Hd. Cap 5/16-18NC x 3/4	1
3	12736	. Washer	2
4	6-06502	. Buttwelder-Tag	1
5	199563	. Key, Hex. 3/32 Across Flats	1
6	405422	. Transformer Assembly 240-V	1
7	198025	. Screw, Hex. Hd. Cap 5/16-18NC x 1/2	8
8	199323	. Washer, Lock 5/16 Std.	12
9	35-9617	. Conduit Anchor.....	1
10	7677	. Grommet.....	1
11	12442	. Stop.....	1
12	135510	. Motor 1/6 H.P. 1 PH.....	1
* 13	303815	. Rear Adapter	1
14	198422	. Screw, Soc. Set 1/4-20NC x 1/4.....	2
15	199115	. Nut, Hex. 1/4-20NC.....	2
16	1006	. Bearing Stud.....	2
17	6-06417	. Jaw Bearing.....	2
18	119859	. L.H. Cam Lever & Pin Assembly	1
	120738	. R.H. Cam Lever & Pin Assembly	1
19	199023	.. Screw, Truss Hd. Mach. 1/4-20NC x 3/4.....	1
20	133971	.. Knob.....	1
21	199356	.. Washer, Lock 1/4 Shakeproof Int	1
22	199115	.. Nut, Hex. 1/4-20NC.....	1
23	119858	.. Pin.....	1
24	4229	.. Roll Pin	1
25	119857	.. Cam Lever Sub-Assembly	1
26	103947	. Bearing	2
27	198423	. Screw, Soc. Set 1/4-20NC x 5/16.....	2
28	121478	. R.H. Cam Sub-Assembly.....	1
29	105116	. Hardened Washer.....	1

***NOTE: Before Serial #290-745446, Item 13 #303815 was 35-614.**

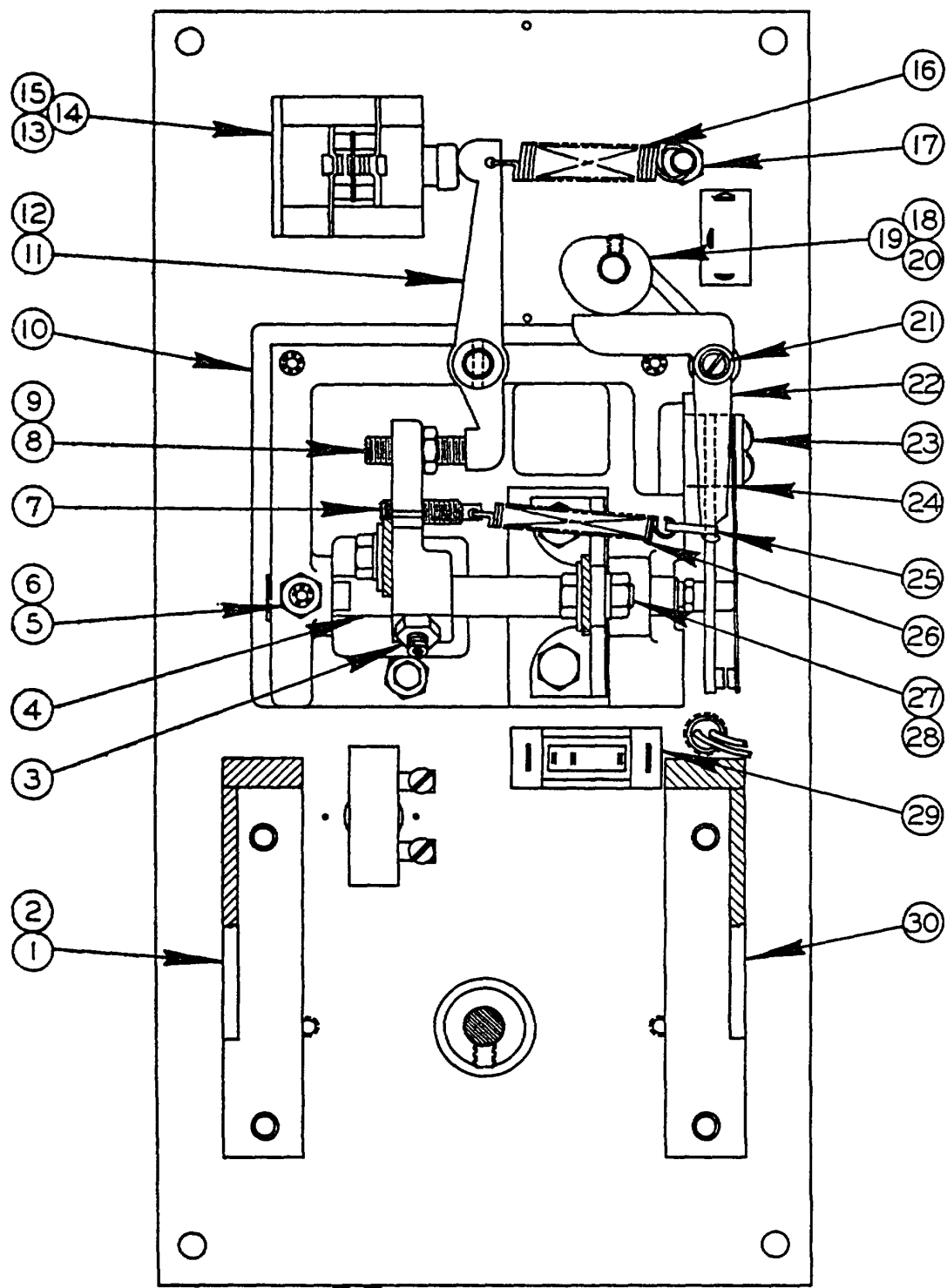

REVISED AND REDRAWN
S.C.L. 12-16-74

SECTION IB-IB

MODEL FIRST MACH. LAST MACH.
DBW-15 290-69101

DBW-15
BUTTWELDER ASSEMBLY

HI-13.3

CODE NO. H1-13.3

DBW #15 BUTTWELDER ASSEMBLY

INDEX NO.	PART NO.	DESCRIPTION	UNITS PER ASS'Y.
Ref.	59788	DBW #15 Buttwelder Assembly	
1	28091	. L.H. Bracket Assembly.....	1
2	199033	. Screw, Truss Hd. Mach. 5/16-18NC x 5/8.....	4
3	198446	. Screw, Soc. Set 5/16-24NF x 3/4.....	1
4	103147	. Slide Rod Assembly (See Detail).....	1
5	198591	. Screw, Soc. Set 1/4-20NC x 5/8 Dog Pt.....	1
6	199114	. Nut, Hex. Jam 1/4-20NC	1
7	35-9549	. Spring Stud	1
8	198447	. Screw, Soc. Set 5/16-24NF x 1-1/4	1
9	199125	. Nut, Hex. Jam 5/16-24NF	2
10	35-9557	. Buttwelder Frame.....	1
11	119884	. Lever Weldment.....	1
12	4227	. Roll Pin	1
13	35-5078	. Welder Switch Sub-Assembly	1
14	198861	. Screw, Rd. Hd. Mach. #8-32NC x 1-1/2.....	2
15	199318	. Washer, Lock #8 Std.....	2
16	104030	. Spring.....	1
17	35-9592	. Spring Stud	1
18	35-9548	. Shaft	1
19	6-06324	. Cam.....	1
20	198410	. Screw, Soc. Set #10-24NC x 1/4.....	1
21	1005	. Pivot	1
22	35-9550	. Lever.....	1
23	198887	. Screw, Rd. Hd. Mach. #10-32NF x 1	2
24	20017	. Cutoff Switch Assembly.....	1
25	6-06313	. Insulator	1
26	6-06339	. Spring.....	1
27	198026	. Screw, Hex. Hd. Mach. 5/16-18NC x 5/8	1
28	199122	. Nut, Hex. 5/16-18NC.....	2
29	135944	. Circuit Breaker.....	1
30	28090	. R.H. Bracket Assembly	1

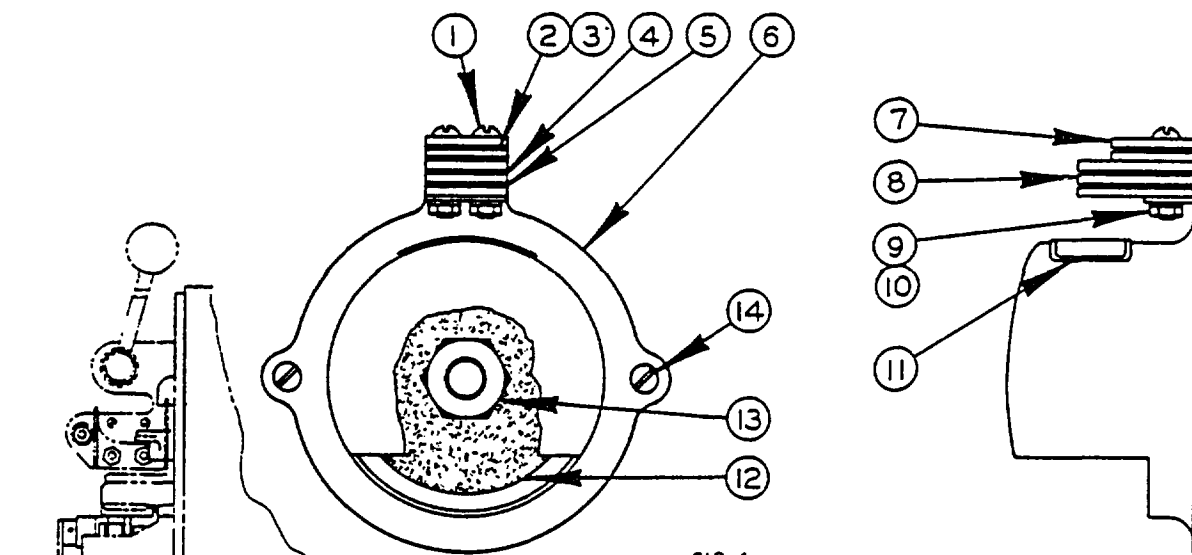

FIG-1
GUARD SUB-ASSEMBLY

NEW DRG
S.W 7-28-70
REVISIONS
WM 8-14-77

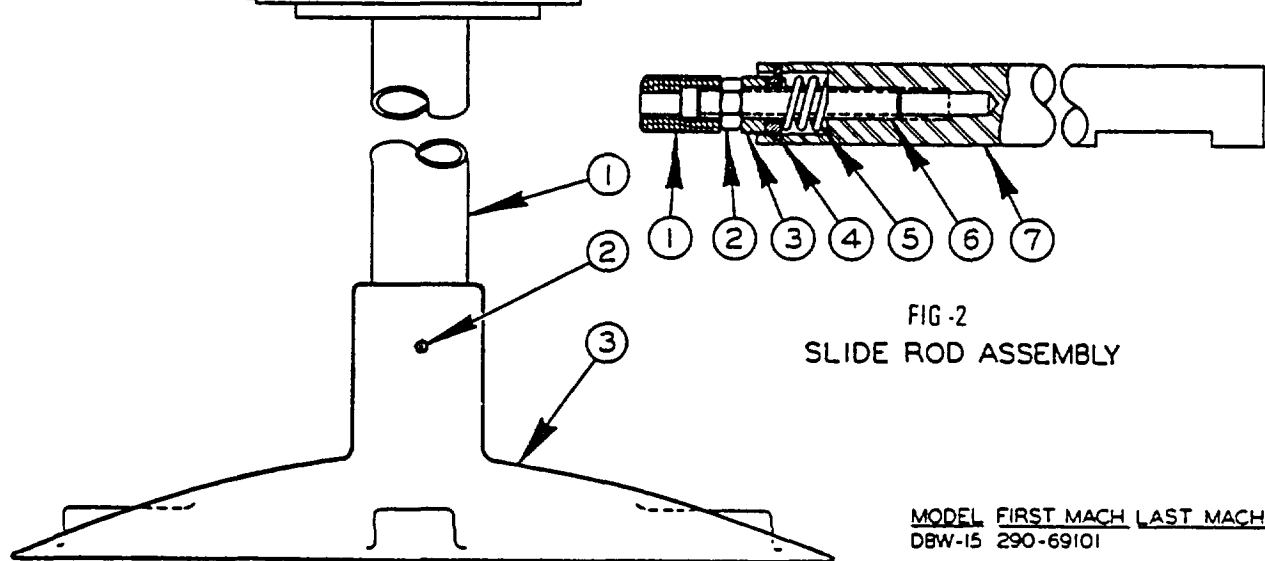

FIG-2
SLIDE ROD ASSEMBLY

MODEL FIRST MACH LAST MACH
DBW-15 290-69101

FIG-3
BUTTWELDER PEDESTAL

CODE NO. H1-13.4

DBW No. 15 BUTTWELDER DETAIL REF. 59788 ASS'Y.

INDEX NO.	PART NO.	DESCRIPTION	UNITS PER ASS'Y.
Ref.	303886	. Guard Sub-Assembly FIG - 1.....	1
1	198888	.. Screw, Rd. Hd. Mach. #10-32 NF x 1	2
2	133798	.. Spacer (.015).....	1
3	133799	.. Spacer (.012).....	1
4	13-06304	.. Spacer (.0359).....	1
5	13-06307	.. Spacer (.040).....	1
6	405735	.. Grinder Wheel Guard.....	1
7	6-06306	.. Block	2
8	13-06306	.. Block	3
9	199113	.. Nut, Hex. #10-32NF (Plated).....	2
10	199319	.. Washer, Lock #10 Std.....	1
11	113447	.. Escutcheon	1
12	13-06501	. Abrasive Wheel.....	1
* 13	303816	. Front Adaptor	1
14	198890	. Screw, Rd. Hd. Mach. 1/4-20NC x 1/4.....	2
Ref.	59788	Buttwelder Assembly	
Ref.	103147	. Slide Rod Assembly FIG - 2.....	1
1	6-06418	.. Knob	1
2	199113	.. Nut, 10-32NF Std.....	1
3	6-06336	.. Collar	1
4	6-06337	.. Key	1
5	6-06338	.. Spring.....	1
6	198420	.. Screw, Soc. Set 10-32NF x 1-1/4.....	1
7	16541	.. Slide Rod	1
Ref.	402520	Buttwelder Pedestal FIG - 3	
1	39653	. Pedestal Top Weldment.....	1
2	198424	. Screw, Soc. Set 1/4-20NC x 3/8.....	2
3	503117	. Pedestal Base	1

***NOTE: Before Ser. #290-745446, Front Adaptor #303816 was replaced with #34-12402 washer and #6-06429 screw.**

REVISED AND REDRAWN
S.W. 12-12-74

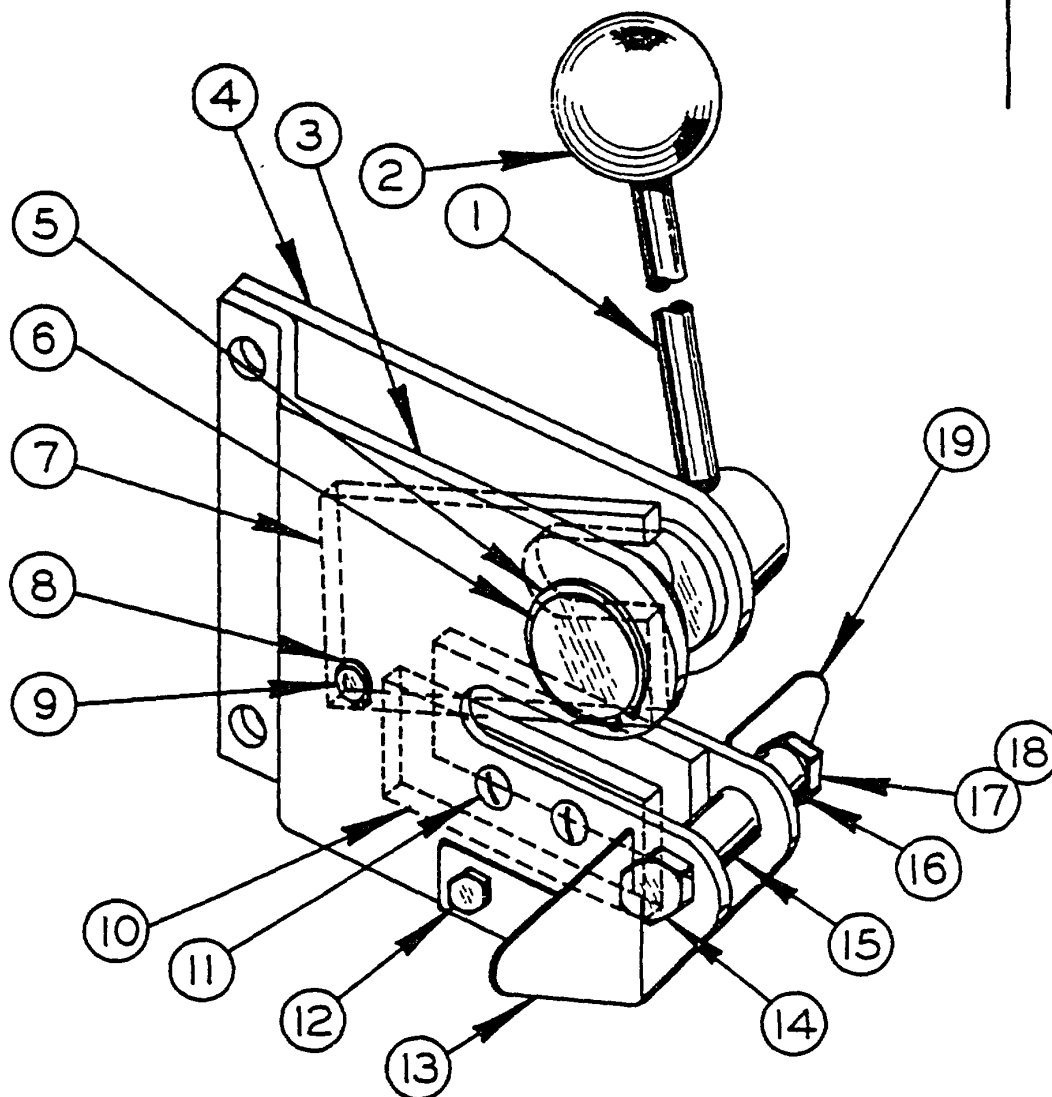

USED ON ALL
MODELS.

BLADE SHEAR ASSEMBLY

HI-19.0

CODE NO. H1-19.0

BLADE SHEAR ASSEMBLY

INDEX NO.	PART NO.	DESCRIPTION	UNITS PER ASS'Y.
Ref.	35-8440	Blade Shear Assembly	
1	35-8438	. Handle	1
2	34-13508	. Ball	1
3	35-8447	. Side Plate L.H.	1
4	35-8448	. Side Plate R.H.	1
5	35-7558	. Retaining Ring.....	2
6	35-8441	. Eccentric.....	1
7	35-8437	. Knife	1
8	35-8582	. Retaining Ring.....	2
9	35-8451	. Pin.....	1
10	100015	. Blade	2
11	198865	. Screw, Rd. Hd. Mach. #10-24NC x 1/4.....	4
12	198011	. Screw, Hex. Hd. Cap 1/4-20NC x 1-1/4	2
13	35-8445	. Square L. H.....	1
14	198012	. Screw, Hex. Hd. Cap 1/4-20NC x 1-1/2	1
15	100016	. Spacer	3
16	35-8585	. Spacer	1
17	199115	. Nut, Hex. 1/4-20NC.....	3
18	199321	. Washer, Lock 1/4 S.A.E. Std.....	3
19	35-8446	. Square R.H.	1

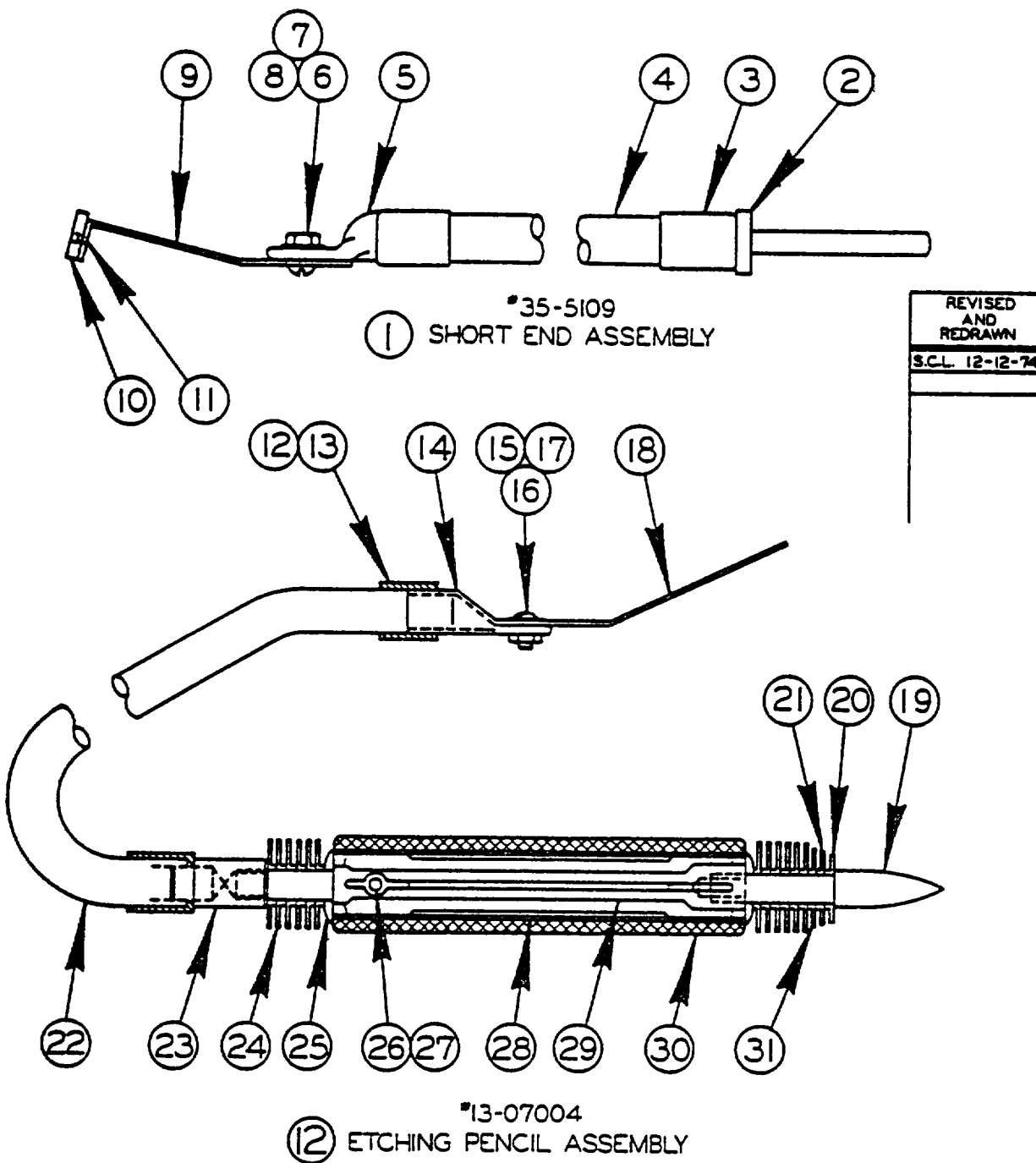

HI-20.0

ETCHING PENCIL ASSEMBLY

CODE NO. H1-20.0

ETCHING PENCIL ASSEMBLY

INDEX NO.	PART NO.	DESCRIPTION	UNITS PER ASS'Y.
* Ref	13-07003	Etching Pencil Assembly	
1	35-5109	. Short End Assembly.....	1
2,	6-07420	.. Plug.....	1
3	2154	.. Ferrule.....	2
4	19546	.. Cable.....	A.R.
5	19545	.. Solder Lug.....	1
6	198852	.. Screw, Rd. Hd. Mach #8-32NC x 5/16.....	1
7	199109	.. Nut, Hex #8-32NC.....	1
8	199292	.. Washer, Brass #8 Std.	1
9	13-07302	.. Terminal Strip.....	1
10	13-07303	.. Insulator.....	1
11	34-18407	.. File Rivet.....	2
** 12	13-07004	. Etching Pencil Assembly.....	1
13	2154	.. Ferrule.....	2
14	19545	.. Terminal Lug.....	1
15	198852	.. Screw, Rd. Hd. Mach. #8-32NC x 5/16.....	1
16	199109	.. Nut, Hex. #8-32NC.....	1
17	199292	.. Washer, Brass #8-Std.	1
18	13-07304	.. Terminal Strip.....	1
19	6-07424	.. Point.....	1
20	6-07310	.. Fin.....	1
21	6-07309	.. Fin.....	1
22	135994	.. Cable.....	A.R.
23	6-07423	.. Connector.....	1
24	6-07307	.. Fin.....	12
25	6-07311	.. Washer.....	2
26	35-5077	.. Stem Assembly.....	1
27	6-07425	... Pin.....	1
28	6-07421	... Tube.....	1
29	6-07201	... Stem.....	1
30	6-07503	.. Tube.....	1
31	6-07308	.. Fin.....	1

*NOTE: For welders shipped before 6-23-44 with ground bushing in panel.

**NOTE: For welders shipped after 6-23-44.

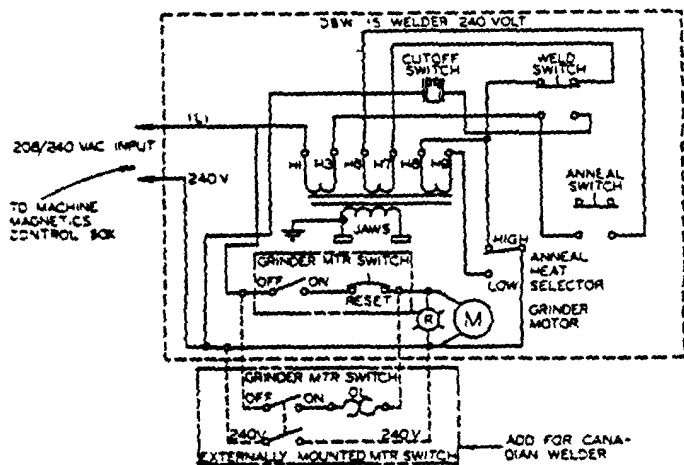

STANDARD 240 VOLT DIAGRAM
*119994-6

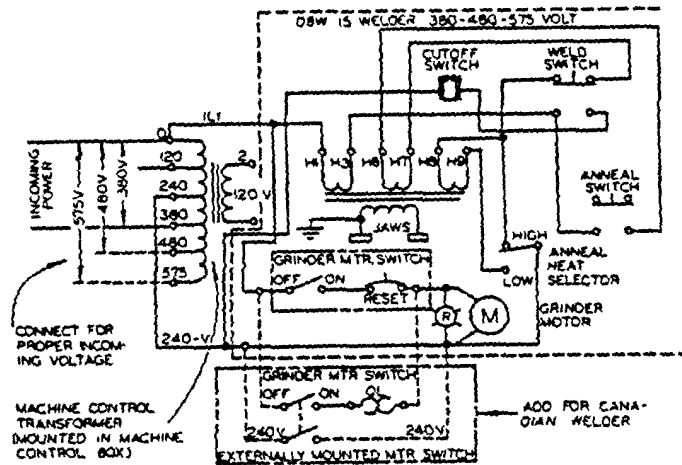

STANDARD 380-480-575-VOLT DIAGRAM
*119995-5

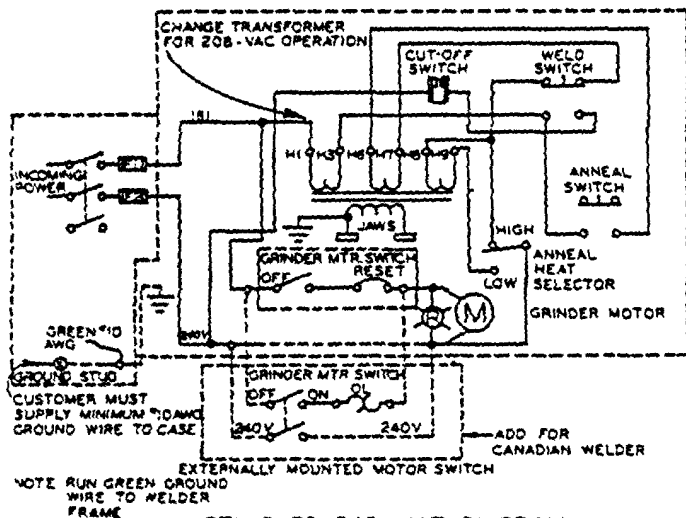

STANDARD 240-VOLT DIAGRAM
PORTABLE
*132816-2

NOTE RUN GREEN GROUND WIRE TO WELDER FRAME

H1-13.5.0

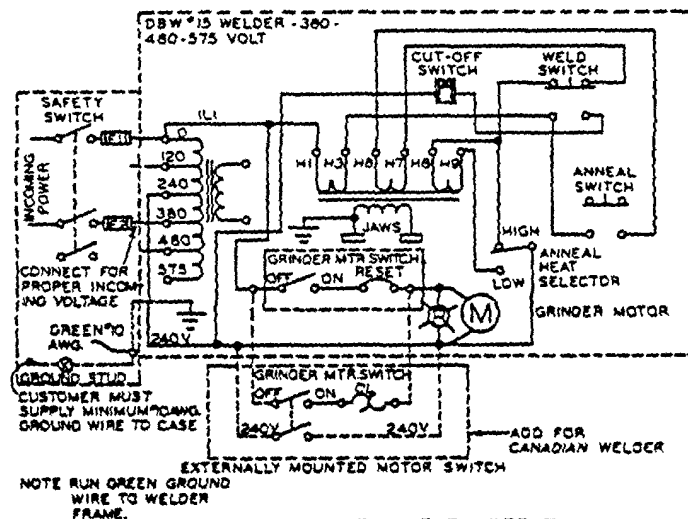

STANDARD DIAGRAM FOR OPERATION
ABOVE 240 VAC PORTABLE
*132817-2

NOTE RUN GREEN GROUND WIRE TO WELDER FRAME.

NEW DRG
SCL 4-12-74
REVISIONS
WM 8-13-77

ELECTRICAL SCHEMATICS
FOR ALL
DBW 15 BUTTWELDERS

FIRST USED APRIL 1974
LAST USED FEB. 1977

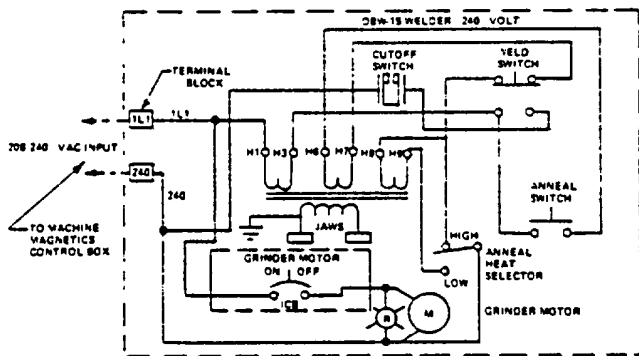

STANDARD 240 VOLT DIAGRAM
No. 119994-7

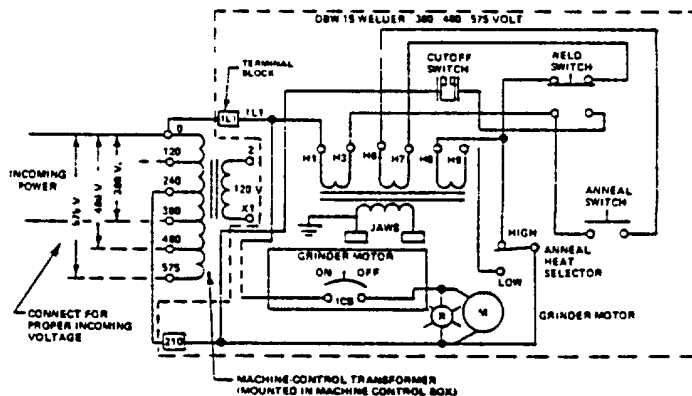

STANDARD 380-480-575-VOLT DIAGRAM
No. 119995-6

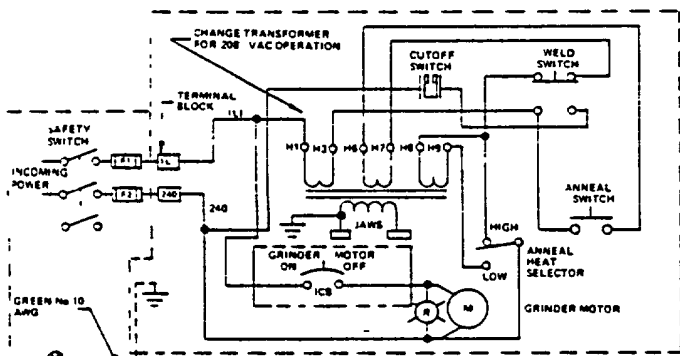

NOTE RUN GREEN GROUND WIRE TO WELDER FRAME

STANDARD 240-VOLT DIAGRAM
PORTABLE
No. 132816-3

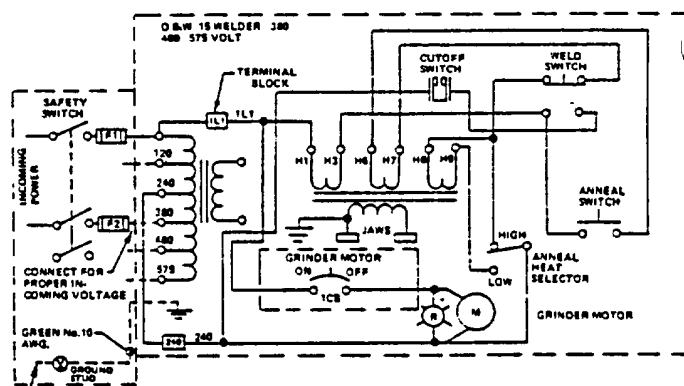

NOTE RUN GREEN GROUND WIRE TO WELDER FRAME

STANDARD DIAGRAM FOR OPERATION
ABOVE 240 VAC PORTABLE
No. 132817-3

NEW DRG.
SCL 4-12-74
REVISIONS
W M 6-15-77

HI-13.5 I

ELECTRICAL SCHEMATICS
FOR ALL
DBW 15 BUTTWELDERS

FIRST USED FEB. 1977

NAME ENGINEERING ADJUSTMENT SUMMARY MODEL DBW-15	PROJECT	1434	NUMBER 120789-2
	SHEET	1 OF 11	

This welder is a "resistance type" buttwelder capable of welding 1/16" x .025" up to 1" x .035" Carbon, Dart and Imperial band.

WARNING:

All adjustments must be made with the power-off, except where specifically instructed otherwise.

WELDER JAW ALIGNMENT:

There are three basic adjustments for the alignment of the welder jaws. They are "Elevation", "Inclination" and "Twist". They are all dependent on one another. Any adjustment of one may require a re-adjustment of one or both of the others. The welder jaws shall be aligned to result in a finish weld which is within 4% of the band gage. The blade alignment guides shall insure that the tooth edge of the band be straight within .004" per 4", measured 2" on either side of the weld.

The initial line up of the welder jaws is accomplished with a straight edge. The final adjustment is made so that the weld produced in a 1" x .085" Imperial band will meet the above specifications.

In order to make the initial adjustment with the straight edge, it is necessary to remove the lower jaw inserts, the insert bearings, and the blade alignment guides. It is advisable to remove the transformer straps from the jaws, the jaw upset spring, the weld lever return spring, and space the jaws approximately 1/8" apart.

Prepared by: Roger Harris	Approved: <i>Ch. Harris</i>	Date: 7-31-69
		120789-2
		REVISIONS
		REVISED & REDRAWN FOR CLARIFICATION SMJTKA 8-1-69
		2
		MAX. JAW GAP PAR. WAS ON SHT. 10 OF 11 WELD LEVER PAR. WAS ON SHT. 8 OF 11 SMJTKA 2-24-70
		2

NAME ENGINEERING ADJUSTMENT SUMMARY MODEL DBW-15	PROJECT 1434	NUMBER 120789-2
	SHEET 2 OF 11	

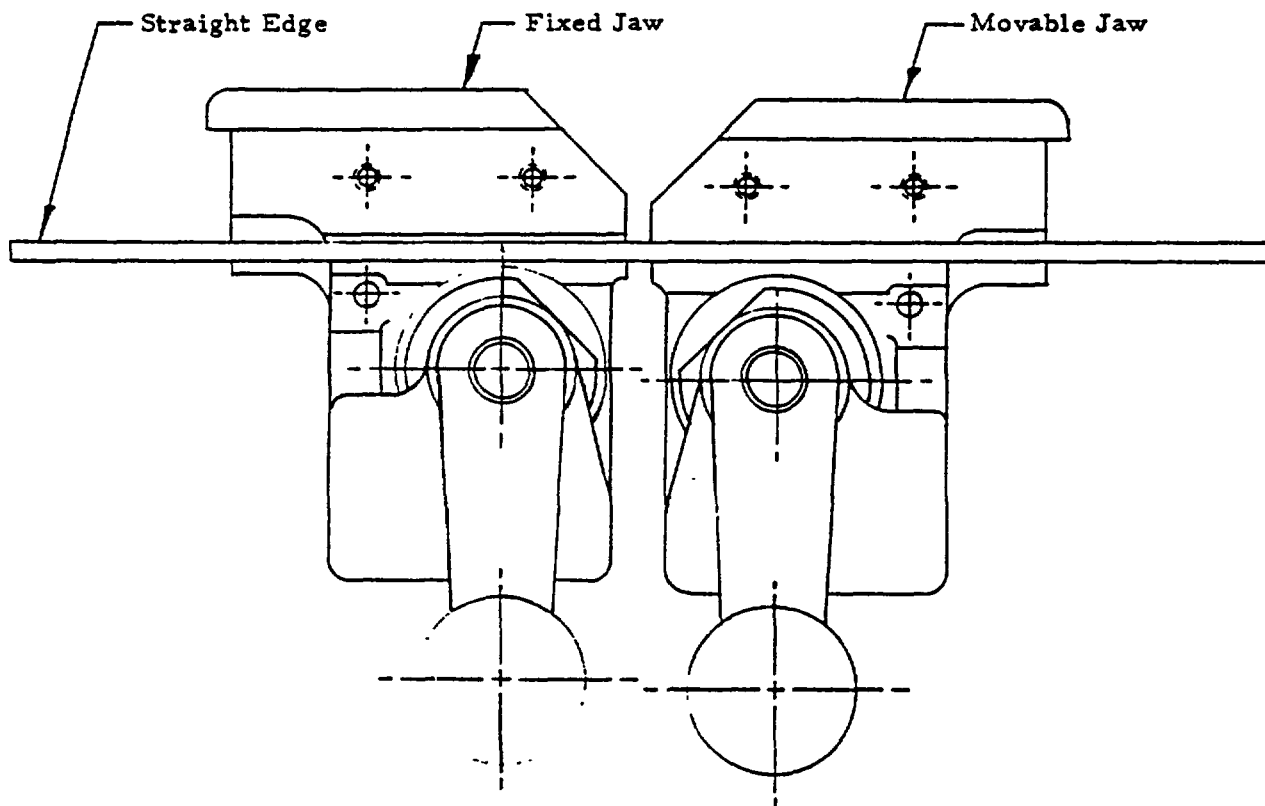

FIG. 1

1. Fig. 1 is an example of jaw elevation misalignment. It is checked with a straight edge. The fixed jaw must be moved to correct this problem. Loosen the mounting screws and move the jaw as required. The mounting screws are located inside the welder case and behind the fixed jaw

Prepared by: Roger Harris

Approved: *Ch. L. Harris*

Date: 7-31-69

REVISIONS

NUMBER
120789-2

NAME ENGINEERING ADJUSTMENT SUMMARY MODEL DBW-15	PROJECT 1434	NUMBER 120789-2
	SHEET 3 OF 11	

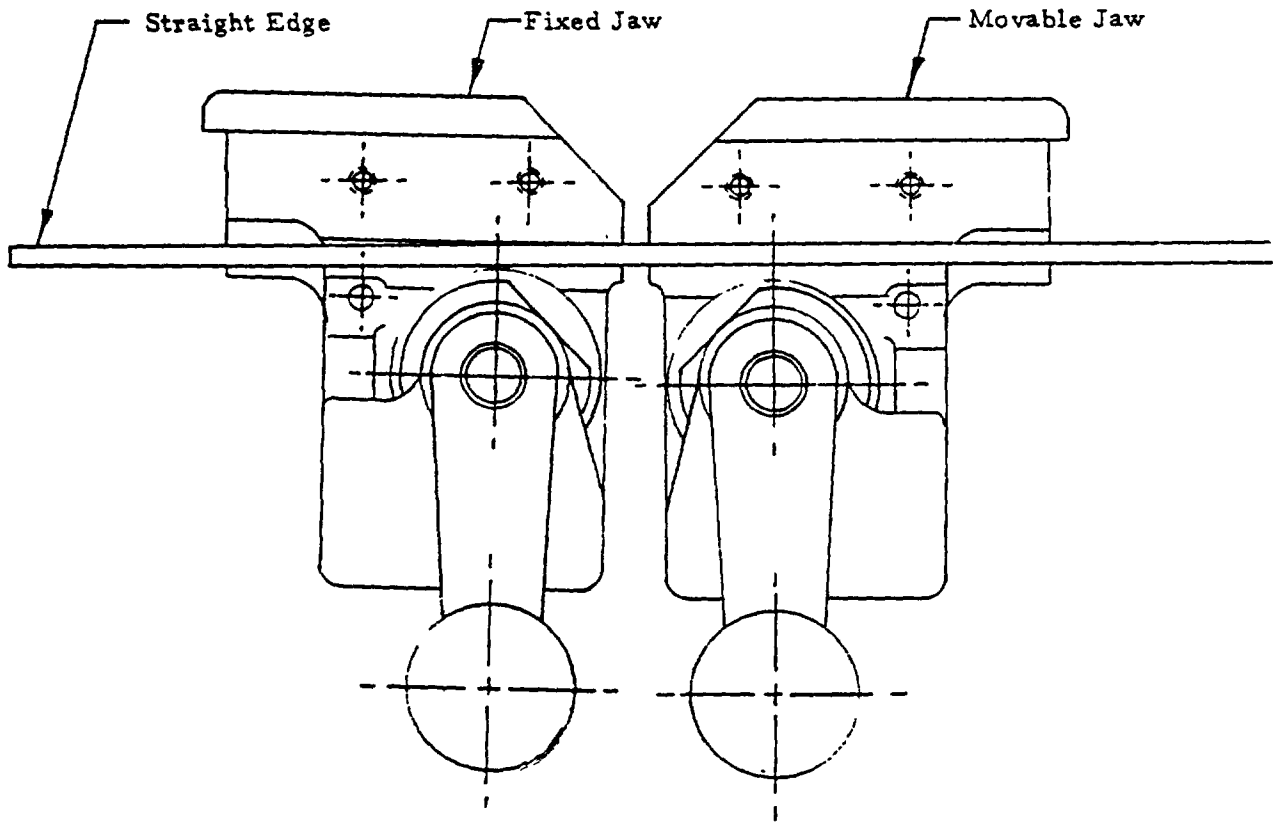

FIG. 2

- Fig 2 is an example of inclination misalignment as checked with a straight edge. The fixed jaw must be moved to correct this problem. Loosen the mounting screws and move the jaw as required. The mounting screws are located inside the welder case - behind the fixed jaw.

Prepared by: Roger Harris

Approved: *Chad*

Date: 7-31-69

REVISIONS

120789-2

NAME ENGINEERING ADJUSTMENT SUMMARY MODEL DBW-15	PROJECT	1434	NUMBER 120789-2
	SHEET	4 OF 11	

Welder Jaw Alignment - - continued

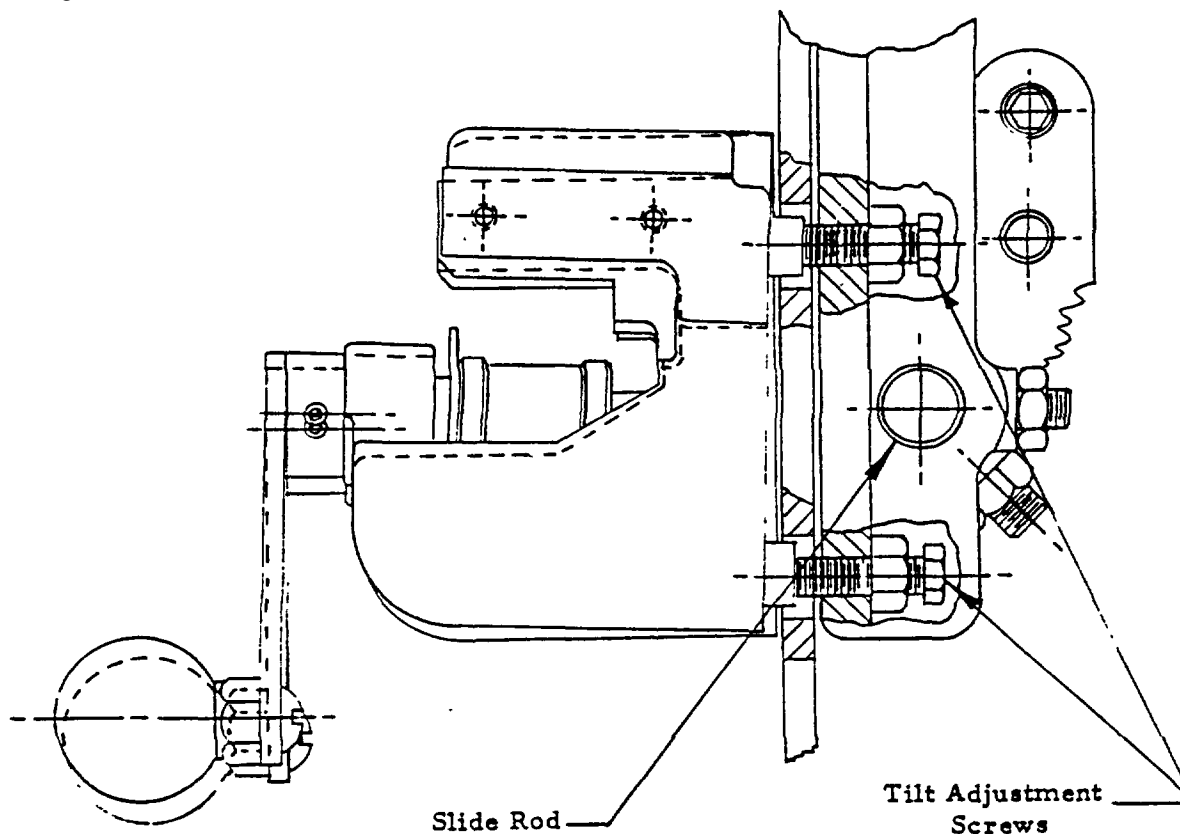

FIG. 3

- Fig. 3 is an example of twist misalignment. The movable jaw must be adjusted to correct this problem. Two adjustment screws are provided. Both of them must be used when making a correction. Care must be taken to prevent any binding on the slide rod.
- Verify the proper setting of the slide rod stop screw (Item 2, Fig. 4). It is adjusted to maintain 1/4 turn clearance between the end of the stop screw and the milled flat on the slide rod. The movable jaw must move freely with both tilt adjustments bearing on the jaw.

Prepared by: Roger Harris Approved: *Chad* Date: 7-31-69

NUMBER	120789-2
REVISIONS	

NAME ENGINEERING ADJUSTMENT SUMMARY MODEL DBW-15	PROJECT 1434	NUMBER 120789-2
	SHEET 5 OF 11	

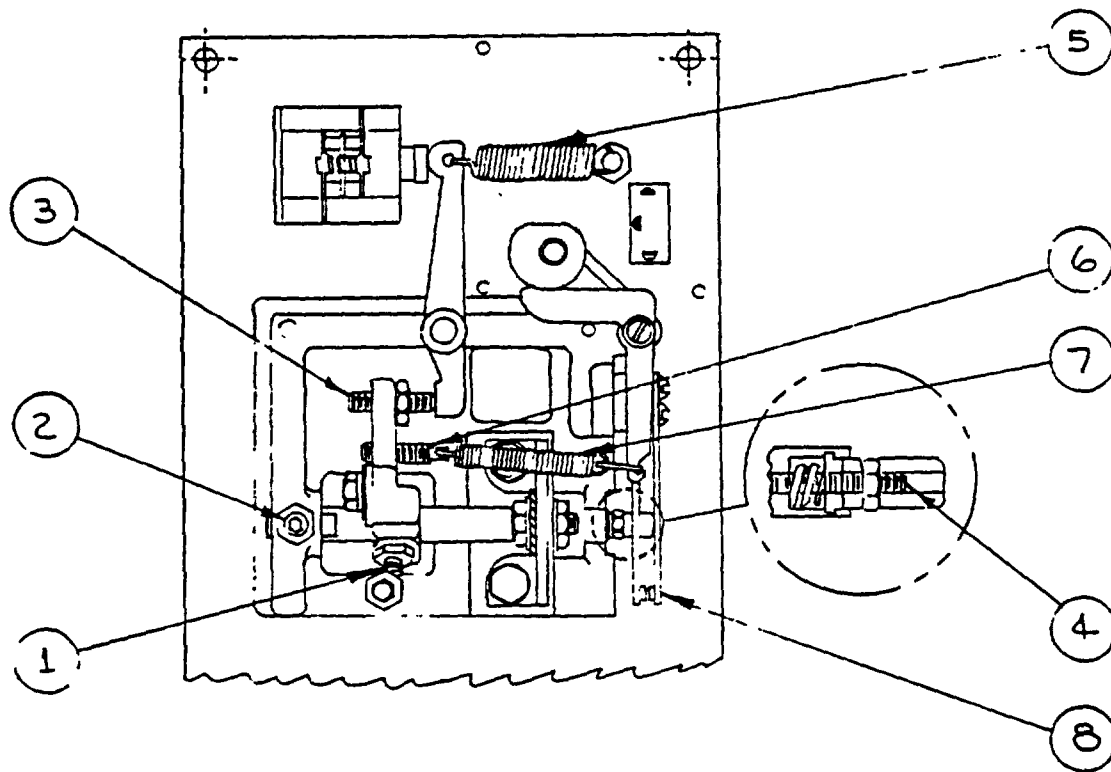

FIG. 4

- 1. Movable jaw lock screw
- 2. Slide rod stop screw
- 3. Jaw gap adjustment screw
- 4. Cut-off adjustment screw
- 5. Weld lever return spring
- 6. Upset force adjustment screw
- 7. Jaw upset spring
- 8. Cut-off switch

Prepared by: Roger Harris

Approved: *Chad*

Date: 7-31-69

REVISIONS

120789-2

NAME ENGINEERING ADJUSTMENT SUMMARY MODEL DBW-15	PROJECT 1434	NUMBER 120789-2
	SHEET 6 OF 11	

Welder Jaw Alignment -- con't.

5. The final jaw alignment cannot be finished until all of the steps in this Adjustment Summary have been completed. Only then can a weld be made that is suitable for alignment purposes.

FINAL JAW GAP

The final jaw gap shall be .075" with the weld lever fully depressed. It is set in the following manner:

1. Loosen the lock screw (Item 1, Fig. 4) that holds the movable jaw to the slide rod.
2. Place a .075" gage between the jaws. The jaws must hold the gage in place.
3. Push the slide rod toward the fixed jaw until the shoulder of its milled flat contacts the slide rod stop screw (Item 2, Fig. 4).
4. Tighten the lock screw (Item 1, Fig. 4) and lock the jam nut on it.
5. Re-check the final jaw gap dimension.

JAW GAP AT ELECTRICAL CUT-OFF

The jaw gap at the electrical cut-off shall be .140". Adjust the electrical cut-off in the following manner, with the power :OFF":

1. Connect a continuity meter to the wires on the cut-off switch.
2. Place a .140" gage between the jaws. The jaws must hold the gage in place.
3. Turn the adjustment screw (Item 4, Fig. 4) as required to just break the circuit with .140" gap. (CW reduces the gap; CCW increases the gap.)

Prepared by: Roger Harris

Approved: *[Signature]*

Date: 7-31-69

NUMBER
120789-2
REVISIONS

NAME ENGINEERING ADJUSTMENT SUMMARY MODEL DBW-15	PROJECT 1434	NUMBER 120789-2
	SHEET 7 OF 11	

WELD UPSET FORCE:

The upset force shall be from 10 to 12 lbs. when measured at the movable jaw with the upset force selector set for the narrowest width band. The approximate locations of the upset force adjustment screw (Item 6, Fig. 4) is with the back end of the screw flush with the cast jaw surface. The final adjustment is made in the following manner:

1. Disconnect the weld lever return spring (Item 5, Fig. 4.)
2. Disconnect the jaw upset spring.
3. Bend the transformer lead that attaches to the movable jaw so that when it is connected it will just urge the jaw to its final jaw gap position.
4. Reconnect the jaw upset spring.
5. Attach a spring scale to the movable jaw and with it, manually pull the jaw to its maximum open position, (approximately 15/32").
6. Gradually release the pull on the scale. Note the reading when the jaw just starts to move.
7. If the spring scale reading at this point does not fall in the required range (10 to 12 lbs.) the upset force adjustment screw must be reset, (Item 6, Fig. 4.)
8. To re-set the screw, disconnect the jaw upset spring (Item 7, Fig. 4) and turn the screw, as required.
9. Replace the jaw upset spring and re-check as in steps 5 and 6.
10. Replace the weld lever return spring.

Prepared by: Roger Harris

Approved: *Chad*

Date: 7-31-69

REVISIONS

NUMBER
120789-2

NAME ENGINEERING ADJUSTMENT SUMMARY MODEL DBW-15	PROJECT 1434	NUMBER 120789-2
	SHEET 8 OF 11	

WELD LEVER DRAG SPRING

The weld lever drag spring (item 1, Fig. 5) serves two functions: First, the upper corner acts as a detent to locate the movable jaw for annealing band; and second, the force exerted by the spring against the weld lever provides the frictional drag to hold the lever at any of the several required initial jaw gap settings for welding. This allows the operator to clamp a blade in the welder or adjust the upset force selector without disturbing jaw gap setting.

The spring is mounted on the band width escutcheon, (item 2, Fig. 5). (Both are secured by two screws.) It is adjusted by shimming between the escutcheon and the spring. Shim as required to obtain both objectives. Shims under either top or bottom screws will affect function, however, the top shim (item 3, Fig. 5) usually is used to establish detent, and the bottom shim (item 4, Fig. 5) to establish frictional drag.

MAXIMUM JAW GAP

With the weld lever in the anneal position, (as located by the detent of the drag spring) and the upset force selector in its widest position, turn the jaw gap adjustment screw (item 3, Fig. 4) to obtain 15/32" jaw gap. Lock the adjustment in place.

Prepared by: Roger Harris

Approved: *Chas. J.*

Date: 7-31-69

REVISIONS

NUMBER
120789-2

NAME ENGINEERING ADJUSTMENT SUMMARY MODEL DBW-15	PROJECT 1434	NUMBER 120789-2
	SHEET 9 OF 11	

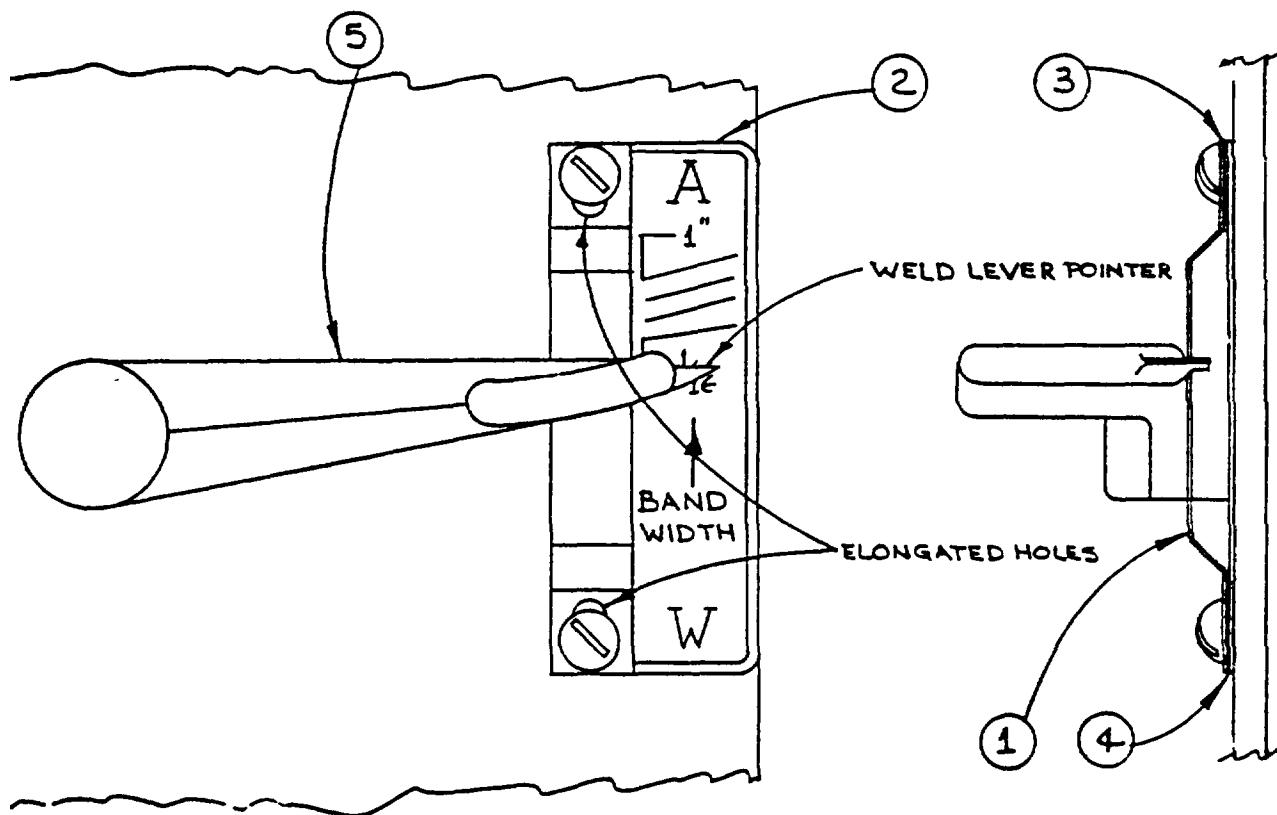

FIG. 5

- 1. Drag spring
- 2. Escutcheon
- 3. Top shim
- 4. Bottom shim
- 5. Weld lever

Prepared by: Roger Harris

Approved: *Chad*

Date: 7-31-69

NUMBER
120789-2
REVISIONS

NAME ENGINEERING ADJUSTMENT SUMMARY MODEL DBW-15	PROJECT 1434	NUMBER 120789-2
	SHEET 10 OF 11	

WELD LEVER must be calibrated in the following manner:

1. The weld lever drag spring must be properly shimmed as described above.
2. Loosen but do not remove the two screws that secure the spring, shims and escutcheon.
3. Place a .150" gage between the jaws and bring the weld lever down, so the jaws just touch the gage.
4. Move the escutcheon (note elongated holes Fig. 5) so the weld lever pointer indicates the narrowest position (the bottom line on the escutcheon that also corresponds with 1/16" band - note Fig. 5) and then tighten the two screws.

BLADE ALIGNMENT GUIDES

The blade alignment guides are used to maintain tooth edge alignment of the ends of the band being welded. Before installing the band guides, check their mounting surfaces on the welder jaws. These surfaces must be in line within .004", when checked with a straight edge. A file may be used to bring the surfaces in line. The guides are aligned to protrude below the band clamping surface of the welder jaws by .025" (Fig. 6). Adjust in the following manner:

1. Loosen the screws holding the "Band Guides" to the jaws.
2. Insert a section of 1" x .035 ga. band into the welder jaws. The band must be out of the jaws (teeth extend in front of alignment guides by at least 3/16") as shown in Fig. 6.
3. Place a .025" shim on top of the band, but within the jaw clamping area.
4. Clamp the jaws.
5. Adjust the "Band Guides" so they touch the side of the 1" x .035 band and lock in place.

Prepared by: Roger Harris

Approved: *[Signature]*

Date: 7-31-69

	REVISIONS	NUMBER 120789-2
--	-----------	--------------------

NAME ENGINEERING ADJUSTMENT SUMMARY MODEL DBW-15	PROJECT 1434	NUMBER
	SHEET 11 OF 11	120789-2

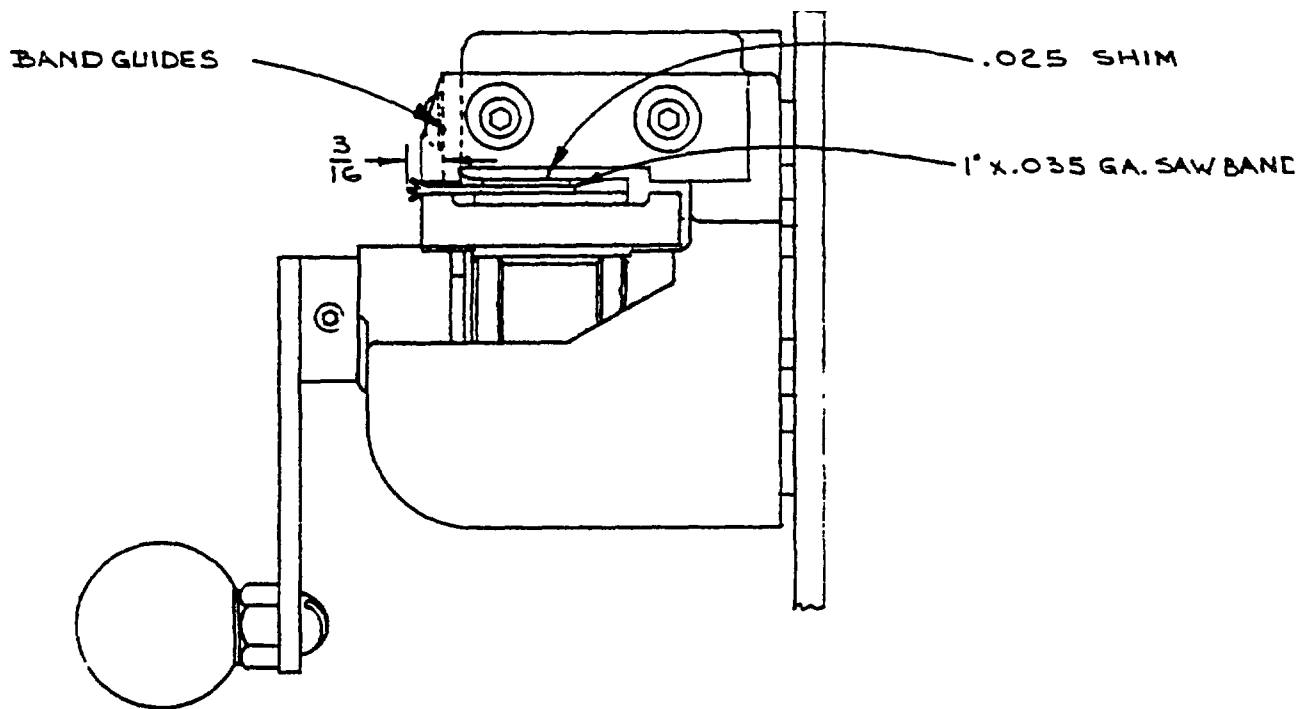

FIG. 6

FINAL JAW ALIGNMENT

A weld must be made in 1" x .035 ga. Imperial band in order to check the final alignment. The finished weld must be within 4% of the band gage. The tooth edge of the band must be straight within .004" in 4" measured 2" on either side of the weld. To make this weld:

1. Set the jaw upset force knob to its maximum wide position.
2. Set the initial jaw gap by adjusting the position of the weld lever. It must be set to the line indicating the widest width.
3. Make the final jaw alignment adjustment as required to result in the tolerances listed.

Prepared by: Roger Harris

Approved: *[Signature]*

Date: 7-31-69

NUMBER
120789-2
REVISIONS

By Order of the Secretary of the Army:

Official:

E. C. MEYER
General, United States Army
Chief of Staff

ROBERT M. JOYCE
Brigadier General, United States Army
The Adjutant General

Distribution:

To be distributed in accordance with Special List.

RECOMMENDED CHANGES TO EQUIPMENT TECHNICAL PUBLICATIONS



SOMETHING WRONG WITH THIS PUBLICATION?

THEN . JOT DOWN THE DOPE ABOUT IT ON THIS FORM. CAREFULLY TEAR IT OUT. FOLD IT AND DROP IT IN THE MAIL!

FROM (PRINT YOUR UNIT'S COMPLETE ADDRESS)

Your mailing address

DATE SENT

Date you fill out this form

PUBLICATION NUMBER TM 9-XXXX-XXX-XX	PUBLICATION DATE Date of TM	PUBLICATION TITLE Title of TM
--	--------------------------------	----------------------------------

BE EXACT. PIN-POINT WHERE IT IS				IN THIS SPACE TELL WHAT IS WRONG AND WHAT SHOULD BE DONE ABOUT IT:
PAGE NO	PARA-GRAPH	FIGURE NO	TABLE NO	
65		102		<p style="font-size: 1.2em;">Callout #243 is missing.</p>

SAMPLE

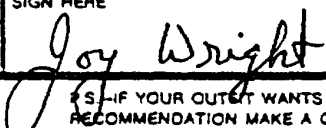
PRINTED NAME, GRADE OR TITLE AND TELEPHONE NUMBER JOY WRIGHT, SSGT., AUTOVON 123/XXXX	SIGN HERE 
--	---

TEAR ALONG PERFORATED LINE

REVERSE OF DA FORM 2025-2

FILL IN YOUR
UNIT'S ADDRESS

FOLD BACK

DEPARTMENT OF THE ARMY

OFFICIAL BUSINESS
PENALTY FOR PRIVATE USE \$300

POSTAGE AND FEES PAID
DEPARTMENT OF THE ARMY
DOD 314



TEAR ALONG PERFORATED LINE

Commander
US Army Armament Materiel Readiness Command
ATTN: DRSAR-MAS
Rock Island, IL 61299

RECOMMENDED CHANGES TO EQUIPMENT TECHNICAL PUBLICATIONS



SOMETHING WRONG WITH THIS PUBLICATION?

THEN. JOT DOWN THE DOPE ABOUT IT ON THIS FORM. CAREFULLY TEAR IT OUT. FOLD IT AND DROP IT IN THE MAIL!

FROM (PRINT YOUR UNIT'S COMPLETE ADDRESS)	
DATE SENT	

PUBLICATION NUMBER TM 9-3405-215-14&P	PUBLICATION DATE 10 July 1981	PUBLICATION TITLE SAW, BAND, METAL CUTTING, MODEL 3613-20
--	----------------------------------	--

BE EXACT PIN-POINT WHERE IT IS				IN THIS SPACE TELL WHAT IS WRONG AND WHAT SHOULD BE DONE ABOUT IT:
PAGE NO	PARA-GRAPH	FIGURE NO	TABLE NO	

PRINTED NAME, GRADE OR TITLE, AND TELEPHONE NUMBER

SIGN HERE

TEAR ALONG PERFORATED LINE

REVERSE OF DA FORM 2026-2

FILL IN YOUR
UNIT'S ADDRESS

FOLD BACK

DEPARTMENT OF THE ARMY

OFFICIAL BUSINESS
PENALTY FOR PRIVATE USE \$300

POSTAGE AND FEES PAID
DEPARTMENT OF THE ARMY
DOD 314



TEAR ALONG PERFORATED LINE

Commander
US Army Armament Materiel Readiness Command
ATTN: DRSAR-MAS
Rock Island, IL 61299

TM 9-3405-215-14&P SAW, BAND, METAL CUTTING - 1981